

Audio CD Recorder

CDR950/951

- *Instructions for use*
- *Mode d'emploi*
- *Instrucciones de manejo*
- *Bedienungsanleitung*
- *Gebruiksaanwijzing*
- *Istruzioni per l'uso*
- *Brugsanvisning*
- *Bruksanvisning*
- *Käyttöohje*
- *Manual de utilização*
- *Οδηγίες χρήσεως*
- *Instrukcja obsługi*



Let's make things better.



PHILIPS

CONTROLS AND CONNECTIONS

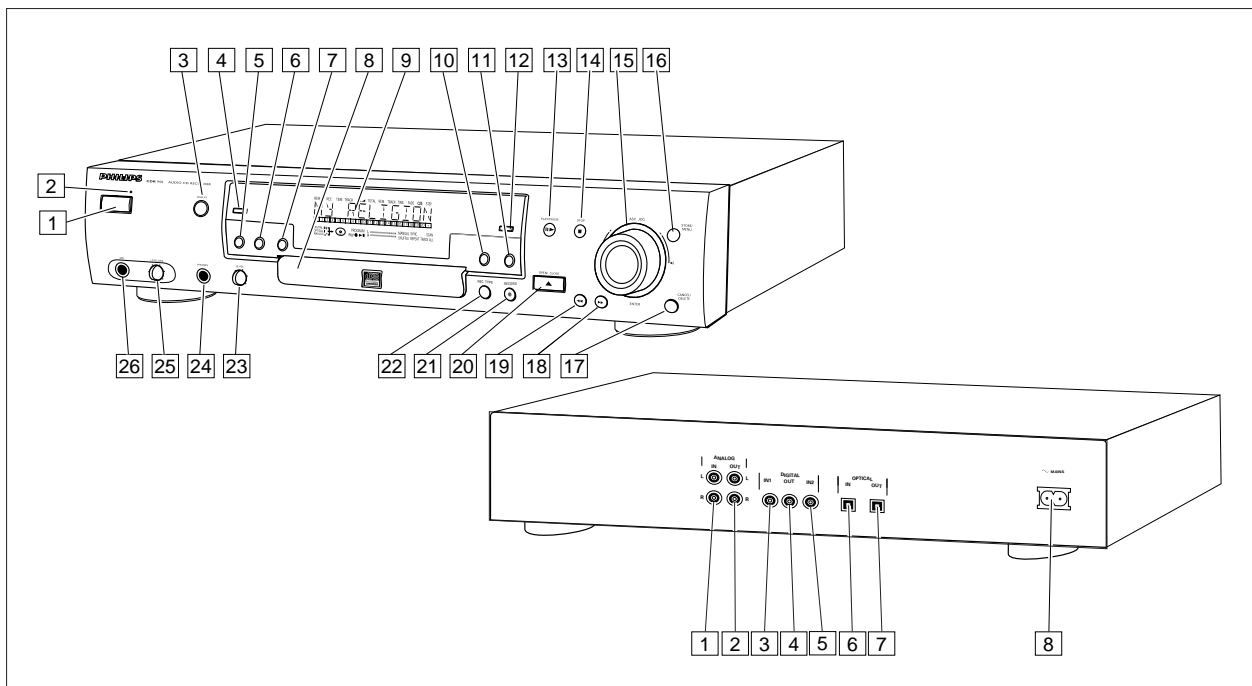

Controls on the front

- 1 **ON/OFF**turns the CD recorder ON and OFF
- 2 Standby indicator
- 3 **DISPLAY**selects display information/text
- 4 **SCROLL**activates scrolling of text over the display (once)
- 5 **PROGRAM**opens/closes program memory
- 6 **REPEAT**repeats play (all, program or track)
- 7 **SHUFFLE**plays CD(RW) or program in random order
- 8 Disc tray
- 9 Displayinformation screen
- 10 **ERASE**selects erasing mode
- 11 **FINALIZE**selects finalize mode
- 12 **SOURCE**selects input source
- 13 **PLAY/PAUSE** ► IIstarts play/interrupts play or recording
- 14 **STOP** ■stops/clears a program
- 15 ◀ **EASY JOG** ▶- previous/next track (Play and (rotate) Program mode)
- recording level control (recording)
- selects settings (menu on)
- ENTER** (push)- plays selected tracks
- selects settings in Menu mode
- programs track numbers
- 16 **STORE/MENU**- enters Menu mode
- stores Menu settings
- 17 **CANCEL/DELETE**- deletes tracks from a program
- deletes text in Menu mode
- returns to a higher level in the menu
- 18 ►►- searches forward
- cursor control in Menu/Prog. review mode

- 19 ◀◀- searches backward
- cursor control in Menu/Prog. review mode
- 20 **OPEN/CLOSE** ▲opens/closes disc tray
- 21 **RECORD**starts recording, finalising, erasing
- 22 **REC(ord) TYPE**selects recording modes
- 23 **LEVEL**headphone volume control
- 24 **PHONES**socket for headphones
- 25 **LEVEL (MIC)**microphone/mix level controller
- 26 **MIC**socket for (stereo) microphone

Note: Unless stated otherwise, all controls are on the front of the CD recorder. When provided on the remote control, you can also use the corresponding buttons, after selecting the CD recorder or separate CD player by pressing CDR or CD.

Connections at the back

- 1 **ANALOG IN**connects to the line output of an amplifier (left and right)
- 2 **ANALOG OUT**connects to the line input of an amplifier (left and right)
- 3 **DIGITAL IN 1**connects to the digital coaxial output of an external CD player
- 4 **DIGITAL OUT**connects to the digital coaxial input of e.g. amplifier or recording device
- 5 **DIGITAL IN 2**connects to the digital coaxial output of an extra CD player
- 6 **OPTICAL IN**connects to the digital optical output of an external CD player
- 7 **OPTICAL OUT**connects to the digital optical input of e.g. amplifier or recording device
- 8 Connection to mains

Connections general

For recording the following inputs are present:

- Digital optical input.
- Digital coaxial input 1.
- Digital coaxial input 2.
- Analog input.

For playback the following outputs are present:

- Digital coaxial output.
- Digital optical output.
- Analog output.

We advise you to connect these to the CD input on your amplifier.

The connections you make will depend upon the possibilities your audio equipment offers. Please refer to the user manuals for your other audio equipment first.

Digital recordings (optical or coaxial) give the best performance in audio and usability (e.g. auto-track). (The digital optical connection is less sensitive to external disturbances).

If your equipment does not offer digital connections, the high quality Analog-Digital-Converter of your CD recorder will ensure very good audio performance when recordings are made from the analog input.

Playback via the digital coaxial output of the CD recorder gives the best audio performance.

If your equipment does not offer digital connections, the high quality Digital-Analog-Converter of the CD recorder ensures a very good sound quality via the analog output.

We advise you to always establish both digital and analog connections. In this way you can always make analog recordings when digital recording is not possible.

We have described the most common ways of connecting the CD recorder. If you still have difficulties with the connections you can always contact the Philips Consumer Service desk in your country.

Analog connections

Analog connection is required for playback of CDs (use cable ②) and for recording from external analog sources (use cable ①).

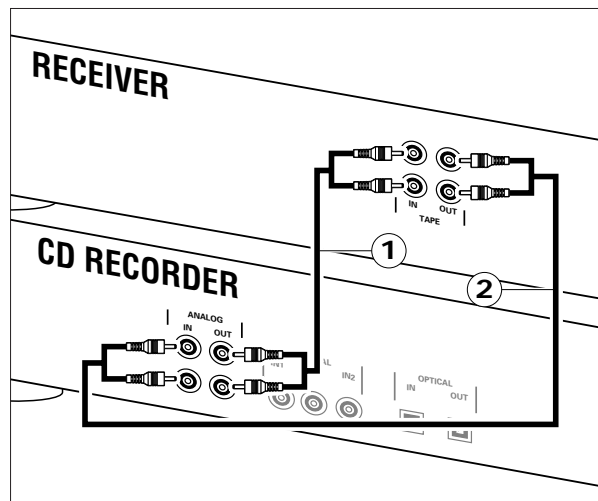

Use the audio cables supplied. Connect the red plugs to the R sockets, and the white plugs to the L sockets.

- 1 For recording, connect cable ① between the ANALOG IN-sockets on the CD recorder and the CDR LINE- or TAPE OUT-sockets of an amplifier.

Note: For recording directly from a CD player, the ANALOG IN sockets of the CD recorder should be connected to the analog output of the CD player.

- 2 For playback, connect cable ② between the ANALOG OUT-sockets on the CD recorder and the input sockets of an amplifier e.g. TAPE IN, CDR or AUX.

Note: Never use the PHONO input.

INSTALLATION

Digital coaxial connections

Digital coaxial connection is only required in case you wish to record from a CD player with a digital coaxial output.

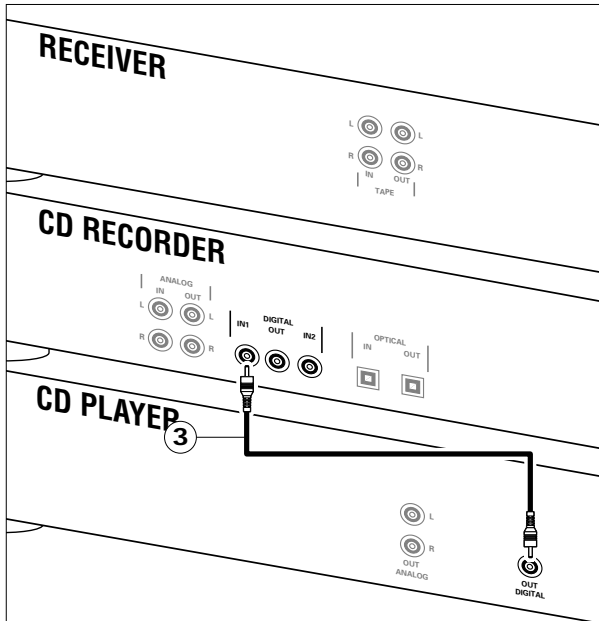

Use the digital coaxial cable supplied.

1 For recording, connect the cable ③ between the DIGITAL IN-1 socket on the CD recorder and the DIGITAL OUT-socket of a CD player.

- If required you can connect an extra digital device (e.g. a DAT or DCC recorder) to the DIGITAL IN 2 socket of the recorder.

Note: Your CD recorder is equipped with a digital coaxial output (DIGITAL OUT). This output can be used for digital playback.

Digital optical connections

Digital optical connection is only required in case you wish to record from a CD player with a digital optical output.

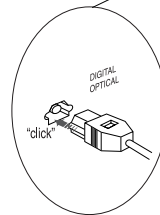
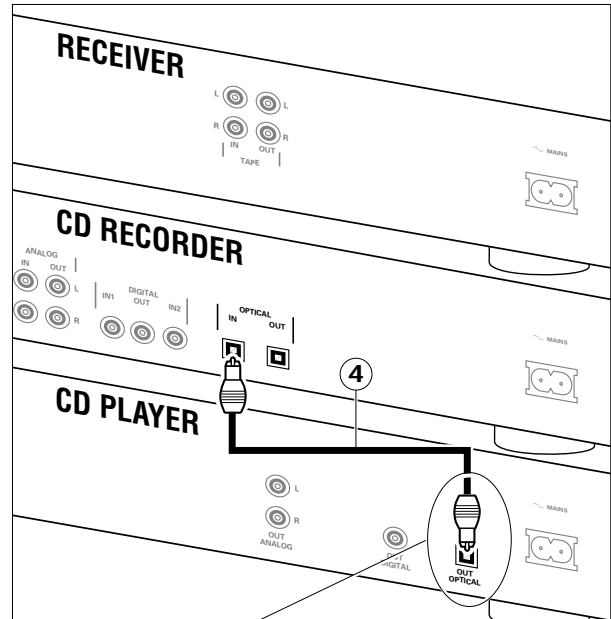

When connecting the Digital Optical cable, make sure it is fully inserted until there is a click.

1 Remove the dust caps from the digital optical connection. (We recommend you save the cap).

2 For recording, connect a fibre-optic cable ④ between the digital OPTICAL IN socket of the CD recorder and the digital-optical output of a CD player.

Note: Your CD recorder is equipped with a digital OPTICAL output. This output can be used for digital playback.

Power supply

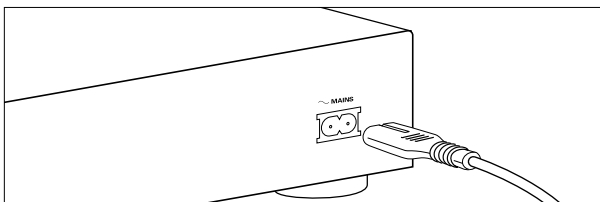

- 1 Plug the power cord supplied into the MAINS connector on the CD recorder, then into a mains socket.
- 2 Press ON/OFF.
→ The recorder is now in Standby mode.
- 3 Press any key to activate the recorder.

Note:

- The CD recorder will automatically adjust to the local mains voltage.
- When the CD recorder is in the Standby mode, it is still consuming some power. If you wish to disconnect your recorder completely from the mains, press ON/OFF on the recorder front.

Setup recommendations

- Place the CD recorder on a solid, vibration free surface.
- Do not place the CD recorder near a source of heat or in direct sunlight.
- Do not use the CD recorder under extremely damp conditions.
- If the CD recorder is placed in a cabinet, make sure that a 2.5 cm space remains free on all sides of the CD recorder/player for proper ventilation.

Inserting batteries in the remote control

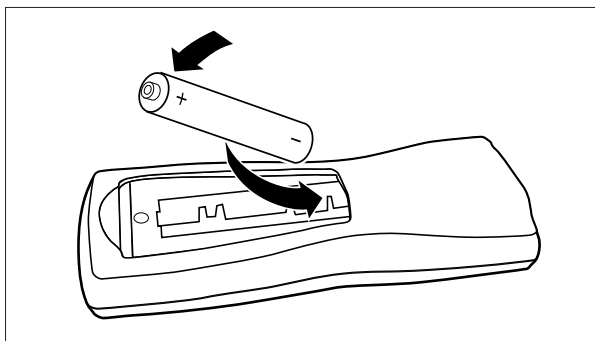

- 1 Open the battery compartment cover.
- 2 Insert 2 batteries ("AA", LR-6 or UM-3; as supplied) as shown.
- 3 Replace the cover.

Note: We recommend you use 2 batteries of the same type and condition.

Batteries contain chemical substances, so they should be disposed of properly.