

PHILIPS

CD 713 / CD 723 Compact Disc Player

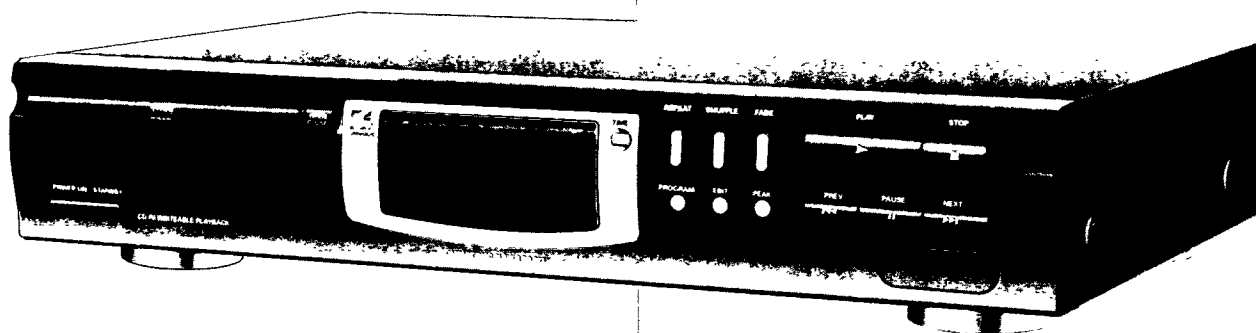

Instructions for use
Руководство по эксплуатации
Instrukcja obsługi
Návod k obsluze
Návod na použitie
Használati útmutató



PHILIPS

ČESKA REPUBLIKÁ

Vystraha!

Tento přístroj pracuje s laserovým paprskem. Při nesprávné manipulaci s přístrojem (v rozporu s tímto návodem) může dojít k nebezpečnému ozáření. Proto přístroj za chodu neotevírejte ani nesnímejte jeho kryty. Jakoukoli opravu vždy svěřte specializovanému servisu.

Nebezpečí!

Při sejmutí krytů a odjištění bezpečnostních spínačů hrozí nebezpečí neviditelného laserového záření!

Chraňte se před přímým zásahem laserového paprsku.

Záruka

Tento přístroj byl vyroben s největší pečlivostí a nejmodernějšími výrobními metodami. Jsme přesvědčeni, že vám bude bezchybně sloužit, pokud budete dodržovat pokyny v návodu. V případě jakékoli závady se laskavě obraťte na svého obchodníka nebo přímo na servisní organizaci firmy Philips. Dbejte též, aby vám prodávající řádně vyplnil záruční list.

Pokud by však byly na přístroji shledány cizí zásahy, nebo byl obsluhován v rozporu s pokyny v návodu, záruční nároky zanikají. Záruční doba je dvanáct měsíců ode dne prodeje.

Pokud byste z jakéhokoli důvodu přístroj demontovali, vždy nejdříve vytáhněte síťovou zástrčku.

Přístroj chraňte před jakoukoli vlhkostí i před kapkami vody.

MAGYARORSZÁG

Minőséggarancia

A garanciajegyben feltüntetett forgalombahozó vállalat a 2/1984. (III.10.) BKM-IpM együttes rendelet értelmében tanúsítja, hogy ezen készülék megfelel a műszaki adatokban megadott értékeknek.

Figyelem!

A meghibásodott készüléket - beleértve a hálózati csatlakozót is - csak szakember (szervíz) javíthatja.

Ne tegye ki a készüléket esőnek vagy nedvesség hatásának!

Garancia

A forgalombahozó vállalat a termékre 12 hónap garanciát vállal.

Névleges feszültség.....220–230 V

Elemes működéshez2 × R03

Névleges frekvencia50 Hz

Teljesítmény

maximális8 W

névleges8 W

készenléti állapotban3,5 W

Érintésvédelmi osztály II.

Tömeg2,9 kg

Befoglaló méretek

szélesség435 mm

magasság86 mm

méllység265 mm

SLOVAK REPUBLIC

Prístroj sa nesmie používať v mokrom a vlhkom prostredí!
Chránite pred striekajúcou a kvapkajúcou vodou!



Данные о произведенном ремонте:

Дата поступления в ремонт: _____

Дата окончания ремонта: _____

№ квитанции: _____

Вид неисправности: _____

Подпись

Штамп сервис-центра

Дата поступления в ремонт: _____

Дата окончания ремонта: _____

№ квитанции: _____

Вид неисправности: _____

Подпись

Штамп сервис-центра



№ талона (Card #)



PHILIPS РОССИЯ

БЫТОВАЯ ЭЛЕКТРОНИКА

ГАРАНТИЙНЫЙ ТАЛОН (warranty card)

ИЗДЕЛИЕ (item) _____ МОДЕЛЬ (type/version) _____ / _____

СЕРИЙНЫЙ № (serial #) _____

ДАТА ПРОДАЖИ (date of purchase) _____

ФИРМА-ПРОДАВЕЦ (seller) _____

ПОДПИСЬ ПРОДАВЦА (seller's signature) _____

ПЕЧАТЬ ПРОДАВЦА (seller's stamp) _____

Настоящий талон действителен только при наличии печати и заполнения всех приведенных выше граф.

(This card is only valid when all information is filled in and the stamp is present.)

ПОКУПАТЕЛЬ (buyer) _____

АДРЕС (address) _____

ТЕЛЕФОН (telephone) _____



Настоящая гарантия предоставляется изготовителем в дополнение к правам потребителя, установленным действующим законодательством Российской Федерации, и ни в коей мере не ограничивает их.

Настоящая гарантия действует в течение одного года с даты приобретения изделия и подразумевает гарантийное обслуживание изделия в случае обнаружения дефектов, связанных с материалами и работой. В этом случае потребитель имеет право, среди прочего, на бесплатный ремонт изделия. Настоящая гарантия действительна при соблюдении следующих условий:

1. Изделие должно быть приобретено только на территории России, причем исключительно для личных бытовых нужд. Изделие должно использоваться в строгом соответствии с инструкцией по эксплуатации с соблюдением правил и требований безопасности.
2. Обязанности изготовителя по настоящей гарантии исполняются на территории России продавцами и официальными обслуживающими (сервис) центрами.
3. Настоящая гарантия не распространяется на дефекты изделия, возникшие в результате:
 - а) химического, механического или иного воздействия, попавших посторонних предметов, насекомых во внутрь изделия;
 - б) неправильной эксплуатации, включая, но не ограничиваясь, использованием изделия не по его прямому назначению и установку в эксплуатацию изделия в нарушение правил и требований безопасности;
 - в) износа деталей отделки, ламп, батарей, защитных экранов, накопителей мусора, ремней, щеток и иных деталей с ограниченным сроком использования;
 - г) ремонта и/или наладки изделия, если они произведены любыми иными лицами кроме обслуживающих центров;
 - д) адаптации и изменения с обычной сферы применения изделия, указанной в инструкции по эксплуатации.

4. Настоящая гарантия действительна по предъявлении вместе с оригиналом настоящего талона оригинала товарного чека, выданного продавцом, и изделия, в котором обнаружены дефекты.

5. Настоящая гарантия действительна только для изделий, используемых для личных бытовых нужд, и не распространяется на изделия, которые используются для коммерческих, промышленных или профессиональных целей.

По всем вопросам гарантийного обслуживания изделий Филипс обращайтесь к Вашему местному продавцу.

Фирма Филипс устанавливает следующие сроки службы изделия:

Группа 1–5 лет

Радио, радиобудильники, магнитолы, переносные магнитолы, телефонные аппараты (проводные) и другая продукция, имеющая небольшую стоимость.

Группа 2–7 лет

Персональные компьютеры и периферийные устройства, цветные телевизоры (включая проекционные), видеомэгафоны, автомобильные магнитолы, Hi-Fi звуковоспроизводящая аппаратура (включая компоненты), видеокамеры и переносные видеоустройства, радиотелефоны (беспроводные), цифровые сотовые телефоны и аппаратура игрового назначения.

Фирма Филипс уделяет большое внимание качеству выпускаемой продукции. При использовании ее для личных (бытовых) нужд с соблюдением правил эксплуатации срок их службы может значительно превысить официальный срок службы, установленный в соответствии с действующим законодательством о правах потребителей.

Фирма Филипс
Факс: (095)755-69-23

English	6	English
Русский.....	14	Русский
Polski.....	22	Polski
Česky.....	30	Česky
Slovensky	38	Slovensky
Magyar.....	46	Magyar

GENERAL INFORMATION

English

Table of contents

GENERAL INFORMATION

Maintenance	6
Technical data	6

CONTROLS AND CONNECTIONS

Controls on the front	7
Connections at the back	7

INSTALLATION AND REMOTE CONTROL

Accessoires	8
Connections	
Usual connection, LINE OUT	8
Digital connection, DIGITAL OUT (CD 723 only)	8
Mains	8
Remote control (CD 723 only)	8
Batteries	8

PLAYBACK

Playing a CD	9
Selecting a track and searching	
Selecting a track during CD play	9
Selecting a track when CD play is stopped	9
Searching for a passage during CD play	9
Random order playing (SHUFFLE)	9
Repeating a CD, a track or a program	9

ADDITIONAL FUNCTIONS

Programming track numbers	10
Clearing the program	10
Loudest passage searching	10
Time display	10
Fading out and in	11
Volume adjustment (CD 723 only)	11
Locking the volume	11
Headphone listening (CD 723 only)	11
Scanning the CD (CD 723 only)	11
Recording setup	12
<i>Environmental information</i>	12

TROUBLESHOOTING

Warning	13
Troubleshooting	13



Maintenance

Clean the CD player with a soft, slightly dampened lint-free cloth. Do not use any cleaning agents as they may have a corrosive effect.

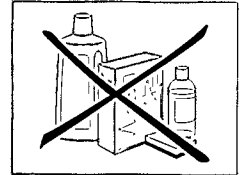

Do not expose the CD player, batteries or CDs to humidity, rain, sand or excessive heat (caused by heating equipment or direct sunlight).

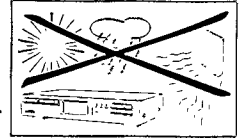

This CD player can play all kinds of Audio Discs such as CD-Recordables and CD-Rewriteables. Do not try to play a CD-ROM, CD-I, CDV or computer CD.

If the CD player cannot read CDs correctly use a commonly available cleaning CD to clean the lens before taking the CD player to repair. Other cleaning methods may destroy the lens. Always keep the tray closed to avoid dust on the lens.

The lens may cloud over when the CD player is suddenly moved from cold to warm surroundings. Playing a CD is not possible then. Leave the CD player in a warm environment until the moisture evaporates.

To clean a CD, wipe it in a straight line from the center toward the edge using a soft, lint-free cloth. A cleaning agent may damage the disc! Never write on a CD or attach a sticker to it.

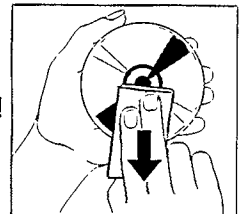

Technical data

Subject to modification without notice.

Standby power consumption	< 5W
Frequency range	20–20,000Hz
Amplitude linearity	< 1dB (1kHz, -90dB)
Dynamic range	95dB (1kHz)
Signal-to-noise ratio	98dB (1kHz, A-weighted)
Channel separation	90dB (1kHz)
Total harmonic distortion	0.006%, -84dB (1kHz)
Audio output	2V RMS ±3dB, 1kΩ
Digital coaxial output	75Ω acc. IEC 958
Impedance headphones	30–600Ω (5V e. m. f. from 120Ω)
Dimensions	435 × 86 × 265mm
Weight	2.9kg

CONTROLS AND CONNECTIONS

English

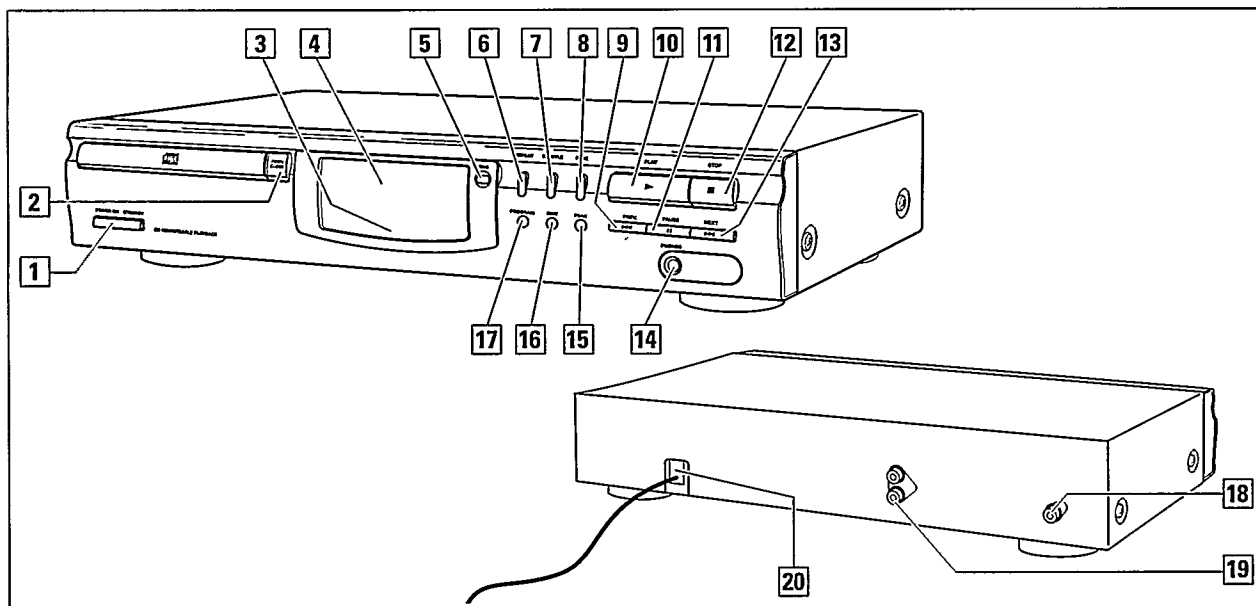

Controls on the front

- 1 POWER ON / STANDBY** ...switches the CD player on and to standby
- 2 OPEN-CLOSE**opens and closes the CD tray
- 3** Sensor for the infrared remote control
- 4** Display
- 5 TIME**switches through the different time information
- 6 REPEAT**repeats a track, a program or the entire CD
- 7 SHUFFLE**plays a CD or a program in random order
- 8 FADE**fades CD play out and in
- 9 PREV. ◀◀**selects the beginning of the current or a previous track, and searches backward
- 10 PLAY ▶**starts CD play
- 11 PAUSE II**interrupts CD play
- 12 STOP ■**stops CD play and clears a program
- 13 NEXT ▶▶**selects the beginning of a subsequent track, and searches forward

- 14 PHONES**(CD 723 only) 6.3mm headphone socket
- 15 PEAK**searches the loudest passage of a CD
- 16 EDIT**changes the settings for recording on tape or CD-Recordable
- 17 PROGRAM**programs track numbers

Connections at the back

- 18 DIGITAL OUT**(CD 723 only) to connect the digital input of a digital audio device
- 19 LINE OUT L R**to connect the audio input of an amplifier
- 20 Mains lead**After all other connections have been made, connect this mains lead to the wall socket.

INSTALLATION AND REMOTE CONTROL

English

Accessories

This CD player is supplied including:

- a remote control (CD 723 only)
- 2 batteries for the remote control (CD 723 only)
- a connection cable
- this instruction booklet

Connections

Usual connection, LINE OUT

- 1 Insert the red plug of the supplied connection cable into R and the other plug into L.
- 2 Insert the other side of the cable into the corresponding sockets of the CD or AUX input of your amplifier.

Important!

You may also use the TUNER or TAPE, but **never** the PHONO input of your amplifier!

Digital connection, DIGITAL OUT (CD 723 only)

Never connect this socket to a non-digital input – such as AUX, CD, PHONO, TAPE – of an amplifier. This output supplies a digital signal and can therefore only be connected to a digital input.

- 1 Insert an optional coaxial cable into DIGITAL OUT.
- 2 Insert the other side of the cable into the digital input of your digital device (e. g. CD Recorder).

Mains

The type plate is located on the back of the CD player.

- 1 Check whether the mains voltage as shown on the type plate corresponds to your local mains voltage. If it does not, consult your dealer or service organisation.
- 2 Connect the mains cable to the wall socket. This switches on the mains supply.

Note: To disconnect the CD player from the mains completely, remove the mains plug from the wall socket.

Remote control (CD 723 only)

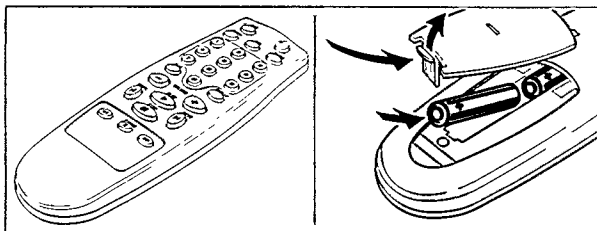

Batteries

- Open the battery compartment of the remote control and insert 2 alkaline batteries, type **AAA** (R03, UM-4).

Remove batteries if they are flat or the remote control is not going to be used for a long time.

Batteries contain chemical substances, so they should be disposed of properly.

- TIME**switches through the different time informations
- ⏻**switches the CD player to standby
- PROGRAM**programs track numbers
- FADE**fades CD play out and in
- SHUFFLE**plays a CD or a program in random order
- Digits 1–0**selects a track by number
- HIGHLIGHT**plays the beginning of each track
- REPEAT**repeats a track, a program or the entire CD
- VOLUME –**decreases the volume level
- VOLUME +**increases the volume level
- PLAY ▶**starts CD play
- PREV. ◀**selects the beginning of the current or a previous track
- NEXT ▶**selects the beginning of a subsequent track
- STOP ■**stops CD play and clears a program
- ◀◀**searches backward
- PAUSE ||**interrupts CD play
- ▶▶**searches forward

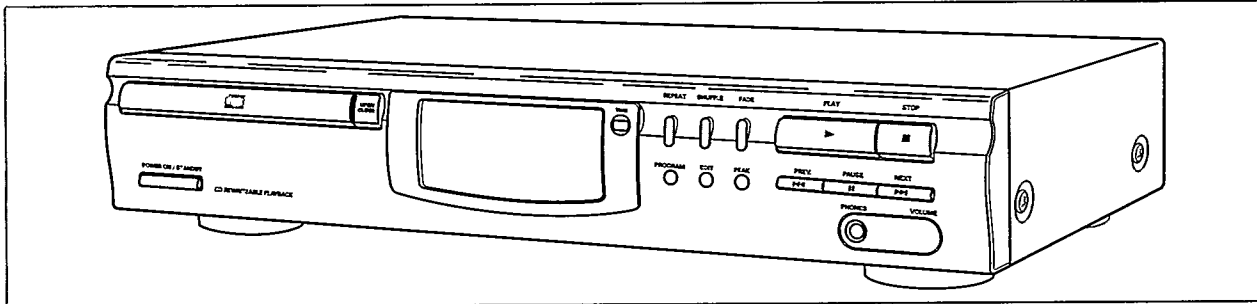

Playing a CD

- 1 Use POWER ON / STANDBY to switch on the CD player.
 - 2 Press OPEN-CLOSE to open the CD tray.
→ OPEN appears on the display.
 - 3 Insert an audio CD (printed side up) and press OPEN-CLOSE to close the CD compartment.
→ READING appears on the display. Then the number of tracks and the playing time is shown.
 - 4 Press PLAY ► to start CD play.
→ The display shows ■■■, TRACK, TIME, and the number and time of the actual track.
- You can interrupt CD play by pressing PAUSE ■■.
→ The display shows ■■■ and the track number and time where playback was stopped.
 - Continue CD play by pressing PAUSE ■■ again.
- 5 Press STOP ■ to stop CD play.

Note: Playback will also stop if the end of the CD is reached.

Selecting a track and searching

Selecting a track during CD play

- Briefly press PREV. ◀◀ or NEXT ▶▶ (PREV. ◀ or NEXT ▶ on the remote control) once or several times to skip to the beginning of the current, previous or subsequent track(s).
- or
- Use the digits 1-0 on the remote control to key in the number of a track.
→ CD play continues with the selected track.

Selecting a track when CD play is stopped

- 1 Briefly press PREV. ◀◀ or NEXT ▶▶ (PREV. ◀ or NEXT ▶ on the remote control) once or several times.
- or
- Use the digits 1-0 on the remote control to key in the number of a track.
- 2 Press PLAY ► to start CD play.
→ Playback starts with the selected track.

Searching for a passage during CD play

- 1 Hold down PREV. ◀◀ or NEXT ▶▶ (◀◀ or ▶▶ on the remote control) to find a particular passage in a backward or forward direction.
→ CD play continues at a low volume.
- 2 Release the button when you have reached the desired passage.

Note: In the shuffle and repeat mode and when playing a program, searching is only possible within the particular track.

Random order playing (SHUFFLE)

- 1 Press SHUFFLE before or during CD play to start shuffle play.
→ SHUFFLE is shown in the display. All the tracks of the CD (or program if available) will now be played in random order.
- 2 Press SHUFFLE again to return to normal CD play.

Repeating the CD, a track or a program

- 1 Press repeatedly REPEAT during CD play.
→ The display shows the different repeating modes.
REPEAT 1: the current track is played repeatedly.
REPEAT: the entire CD or program (if available) is played repeatedly.
- 2 Press REPEAT until the display indication disappears to return to normal CD play.

Note: It is possible to activate the different playing modes at the same time, e. g. you can repeatedly play the entire CD or program in random order (PROGRAM REPEAT SHUFFLE).

ADDITIONAL FUNCTIONS

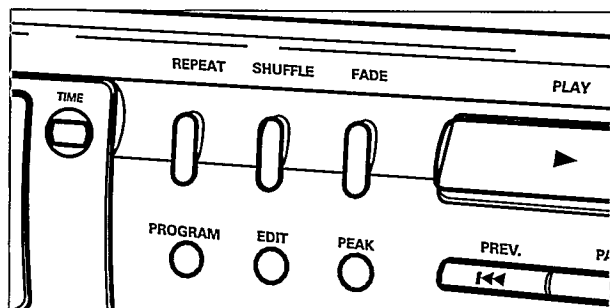

Programming track numbers

You can select a number of tracks and store these in the memory in the desired sequence. You can store any track more than once. At most, 30 tracks can be stored in the memory.

- 1 Press PROGRAM to start programming.
→ PROGRAM flashes.

Note: If you press PROGRAM while playing a CD, the actual track will be added to the program.

- 2 Press PREV. ◀◀ or NEXT ▶▶ (PREV. ◀ or NEXT ▶ on the remote control) to select the desired track.
or
• Key in the number of a track with the digits 1–0 on the remote control.
- 3 Press PROGRAM to store the track number.
→ TRACK, TOTAL TIME, and the number of the programmed track is displayed. The number of programmed tracks is increased and the time of the track is added to the total time of the program.
- 4 Repeat steps 2 and 3 for all tracks to be programmed.
- 5 Press STOP ■ to end programming.
→ PROGRAM lights permanently.
 - It is possible to review the program using the PREV. ◀◀ or NEXT ▶▶ (PREV. ◀ or NEXT ▶ on the remote control). You can add more tracks by pressing PROGRAM like you have done before.
- 6 Press PLAY ▶ to start program play.

*Note: If you try to store more than 30 tracks
PROGRAM FULL scrolls through the display.*

Clearing the program

- 1 If necessary press STOP ■ to stop program playing.
- 2 Press STOP ■ to clear the program.
→ PROGRAM CLEAR scrolls through the display,
PROGRAM disappears and your program is cleared.

Note: The program will also be cleared if you open the tray.

Loudest passage searching

You can search for the loudest passage of a CD or program. This will help you in adjusting your recording device if required.

- 1 If necessary press STOP ■ to stop CD play.
- 2 Press PEAK to start searching.
→ PEAK starts flashing. Searching may need a few minutes. Then 4 seconds of the loudest passage are played repeatedly.
 - You can interrupt peak play by pressing PAUSE ■. Continue peak play by pressing PAUSE ■ again.
- 3 Press STOP ■ to stop playing.
or
• Press PLAY ▶ to start CD play.

Time display

You can display time information which is stored on the CD.

While playing a CD or a program the number and elapsed time of the actual track, and TIME are displayed.

- Press TIME several times to display:
→ The number and remaining time of the actual track, and REM TIME.
→ The number of the actual track, the total elapsed time of the CD, and TOTAL TIME.
→ The number of the actual track, the total remaining time of the CD, and TOTAL REM TIME.

Note: If you press TIME when the CD is not playing you may only display the total time of the CD.

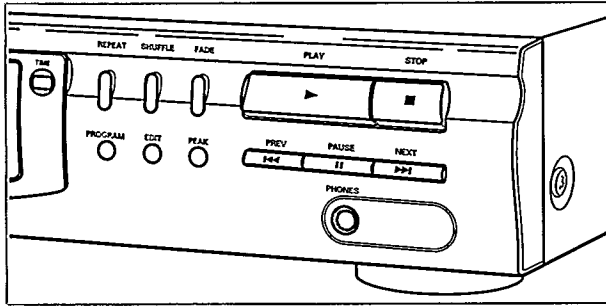

Fading out and in

You can fade out and in CD play, e. g. to stop and start a recording softly.

- 1 Press FADE during CD play to fade out.
 - The display shows ■■■■ in steps. The volume is lowered continuously until CD play is paused.
- 2 Press FADE again to fade in.
 - The display shows ■■■■ in steps. CD play starts and the volume is raised continuously to its previous level.

Note: You may use FADE anytime when CD play is paused to fade in.

Volume adjustment (CD 723 only)

The volume of the CD player can be adjusted. This affects the DIGITAL OUT output as well.

- Press VOLUME – or VOLUME + on the remote control.
 - The volume of the CD player is lowered or raised. The display shows the actual value between VOL MIN and VOL MAX.

Important!

VOLUME –/+ is altering the signal of the output. Before recording set the volume to VOL MAX and do not change during recording.

Locking the volume

It is possible to lock the output volume to its maximum. This affects the DIGITAL OUT output as well. Locking the volume can be useful when recording from the CD-player.

- Keep EDIT pressed for more than 2 seconds.
 - If the volume was unlocked:*
 - The display shows VOL FIX and the volume is locked.
 - If the volume was locked:*
 - The display shows VOL MAX and the volume is unlocked.

Note: If you press VOLUME –/+ and the volume is locked the display shows VOL FIX.

Headphone listening (CD 723 only)

- 1 Connect your headphones to the 6.3mm PHONES socket.
- 2 Press VOLUME – or VOLUME + on the remote control to adjust the volume (see "Volume adjustment").

Important!

The volume of the headphones is in line with the volume of the output. Therefore do not use VOLUME –/+ during recording.

Scanning the CD (CD 723 only)

It is possible to listen to the beginning of each track of a CD or program. You can choose whether to play 10, 20 or 30 seconds of each track.

- 1 Press HIGHLIGHT on the remote control repeatedly to switch through the different scan modes.
 - SCAN 10, SCAN 20, SCAN 30, SCAN OFF ... (SCAN OFF aborts the scan function).
 - 2 As soon as the desired scan mode is displayed do not press the button again.
 - After 1 second scanning starts. The number and remaining time of the actual track, and REM TIME are displayed.
- You can interrupt scan by pressing PAUSE || . Continue scan by pressing PAUSE || again.
- 3 Press STOP ■ to stop scanning.
 - or
 - Press PLAY ▶ to start CD play with the actual track.

Note: If you press HIGHLIGHT while SHUFFLE is active, shuffle will be stopped before scanning.

ADDITIONAL FUNCTIONS

English

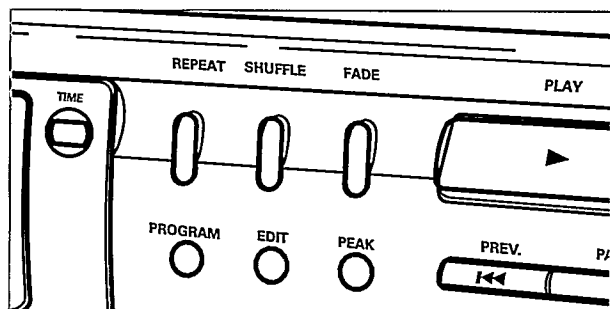

Recording setup

It is possible to set up the CD player in a way that it will calculate which tracks will fit on your recording media. It is only possible to use the edit function if a disc has not more than 29 tracks.

If you use *NORMAL* the recording stops after the last track that fits on one side of your recording media. Notice that CD-Recordables are single-sided only! If you use *OPTIMAL* some tracks will be skipped to minimise the unused space on your recording media. The sequence of the tracks stays as the original.

- 1 Insert a CD and, if desired, program track numbers.
- 2 Press EDIT to start the setup.
→ The display shows EDIT and *NORMAL*.
- 3 Press PREV. ◀◀ or NEXT ▶▶ (PREV. ◀ or NEXT ▶ on the remote control) to switch through the different scan modes.
→ *NORMAL*, *OPTIMAL*, *STOP*... (*STOP* aborts the edit function).
- 4 As soon as the desired edit mode is displayed press EDIT.
→ The display shows C 90. >

5 Press PREV. ◀◀ or NEXT ▶▶ (PREV. ◀ or NEXT ▶ on the remote control) to switch through the different recording times and media.

→ C 100, C 120, CDR 21, CDR 60, CDR 74, C 30, C 45, C 60, C 90...

Note: C is for cassette, CDR is for CD-Recordable and CD-Rewriteable and therefore for single-sided recording only.

6 As soon as the desired recording time and media is displayed press EDIT.

→ The number of tracks and the playing time are displayed.

7 Start your recording and press PLAY ▶ to start CD play.

→ If cassette (C) was selected the CD player pauses after playing the calculated tracks for side A. If CD-Recordable (CDR) was selected the CD player stops.

8 If required switch tape sides.

9 Press PLAY ▶ to start CD play again.

→ The number of tracks and the playing time are displayed. The remaining tracks for side B are played.

Note: It is possible to switch between A and B by using PREV. ◀◀ or NEXT ▶▶ (PREV. ◀ or NEXT ▶ on the remote control).

Environmental information

All redundant packing material has been omitted. We have done our utmost to make the packaging easily separable into three mono materials: cardboard (box), polystyrene foam (buffer) and polyethylene (bags, protective foam sheet).

Your set consists of materials which can be recycled if disassembled by a specialized company. Please observe the local regulations regarding the disposal of packing materials, exhausted batteries and old equipment.

WARNING

Under no circumstances should you try to repair the CD player yourself as this will invalidate the guarantee.

If a fault occurs, first check the points listed below before taking the set for repair.

If you are unable to solve a problem by following this checklist, consult your dealer or service center.

Problem	Possible cause	Solution
No power	Mains cable is not securely connected.	Connect mains cable properly.
No or bad sound	CD 723 only: volume is too low.	Adjust volume.
	Interference caused by electric equipment like TVs, computers, engines, etc.	Keep the CD player away from electrical equipment.
	Loose or wrong connections.	Connect the CD player correctly.
No or bad headphone sound (CD 723 only)	Volume is too low.	Adjust VOLUME -/+.
	Headphone plug is dirty.	Clean headphone plug.
No or low quality recording	CD 723 only: volume is too low.	Adjust VOLUME -/+.
	Loose or wrong connections.	Connect the CD player correctly.
No reaction to operation of any keys	Electrostatic discharge.	Disconnect the CD player from mains, reconnect after a few seconds.
NO DISC is displayed	No CD is inserted.	Insert a CD.
	The CD is badly scratched or dirty.	Replace or clean the CD.
	The CD is inserted upside down.	Insert CD with label upwards.
DISC NOT FINALIZED is displayed	The CD-RW (or CD-R) is not properly recorded for the use on a standard CD player.	Read the instruction booklet of your CD-Rewriteable (or CD-Recordable) recorder on how to finalize a recording.
	The CD is badly scratched or dirty.	Replace or clean the CD.
WRONG TRACK is displayed	Chosen track number is higher than the highest track number on the CD.	Key in a track number within the range of the track numbers on the CD.
0 0:00 is displayed	First track of the CD is longer than the first side of the chosen recording media.	Choose a recording media with a recording time longer than the first track of the CD.
VOL FIX is displayed (CD 723 only)	Volume is locked.	Press EDIT for more than 2 seconds to unlock the volume.
CD skips tracks	SHUFFLE or PROGRAM is active.	Switch off SHUFFLE or PROGRAM play.
	The CD is badly scratched or dirty.	Replace or clean the CD.
	Laser lens is dirty.	Clean with a commonly available cleaning CD.
	The laser lens is steamed up.	Wait until the lens has cleared.
Remote control does not function properly (CD 723 only)	Batteries are inserted incorrectly.	Insert batteries correctly.
	Batteries are flat.	Insert fresh batteries.
	Distance to the CD player is too large.	Reduce distance.

English

Русский

Polski

Česky

Slovensky

Magyar

Meet Philips at the Internet
<http://www.philips.com>

