

CD Soundmachine

AZ2060

User Manual
Manuel d'utilisation
Manual del usuario
Benutzerhandbuch

Meet Philips at the Internet
<http://www.audio.philips.com>

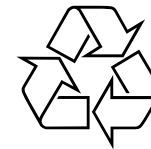

AZ 2060



PHILIPS



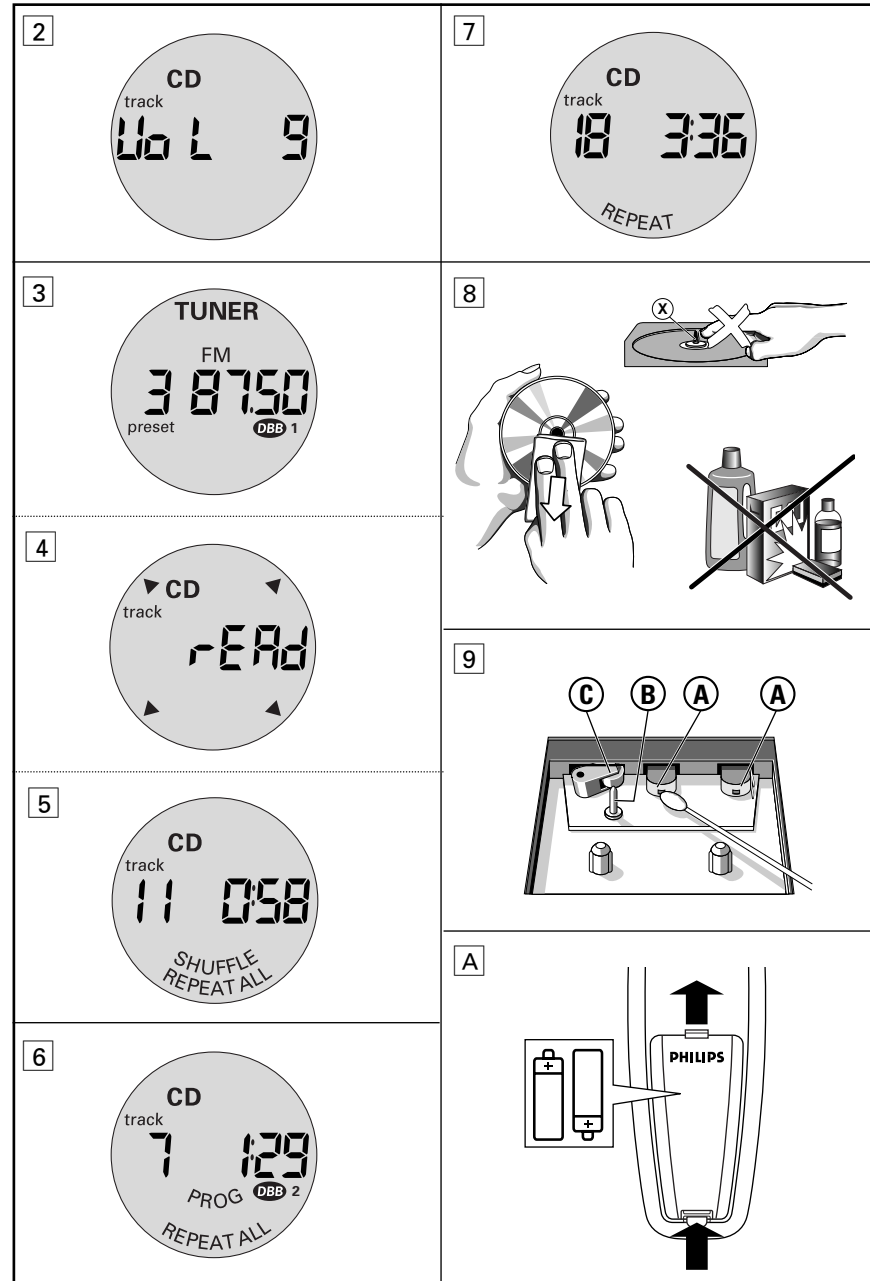
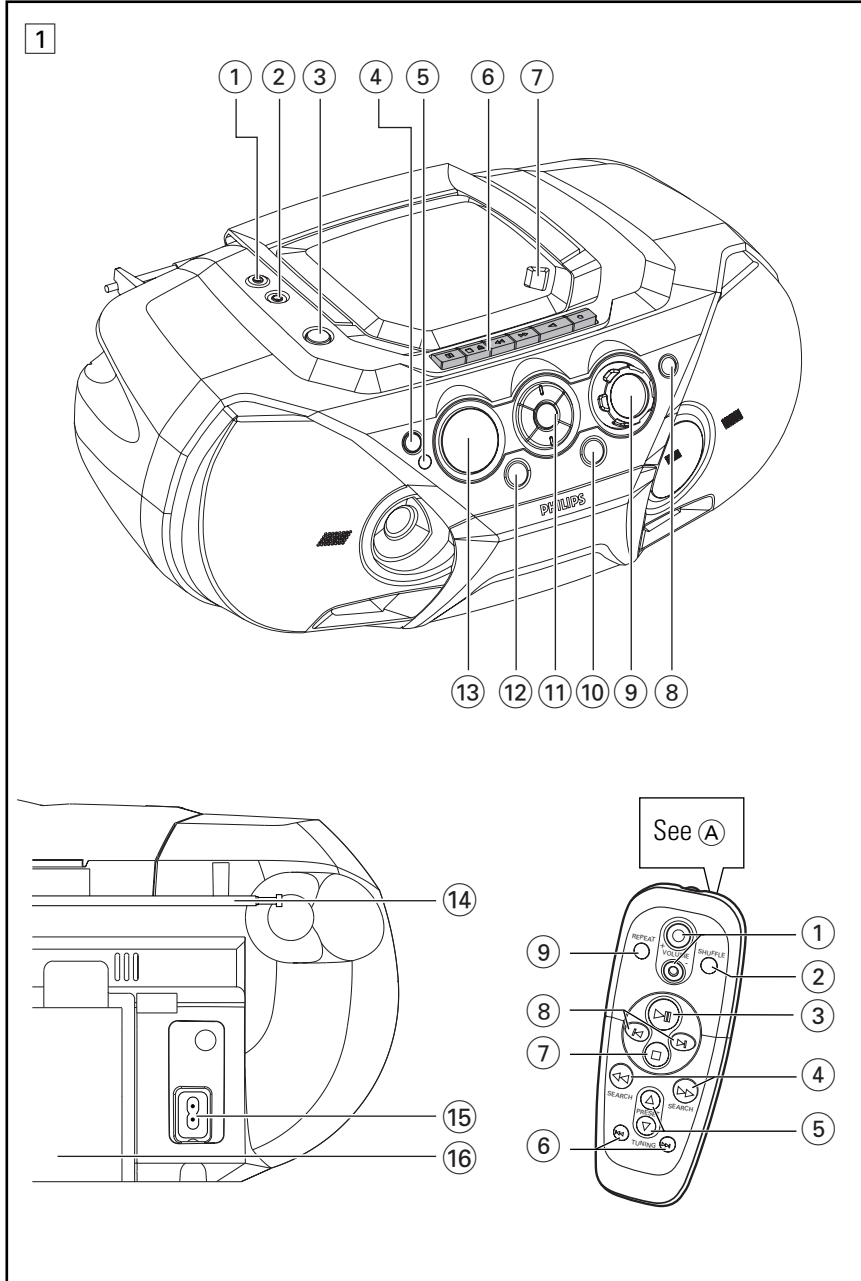

English

SUPPLIED ACCESSORIES

— AC mains lead

TOP AND FRONT PANELS (See [1])

① — 3.5 mm stereo headphone socket

Helpful hints: The speakers will be muted when headphones are connected to the set.

② **AUX** — 3.5 mm LINE-IN jack for external audio appliance

③ **STANDBY** — power on/ off switch

④ **Source selector** — selects CD/ TUNER/ AUX/ TAPE function

⑤ **IR Sensor** — infrared sensor for remote control

⑥ **Cassette recorder keys**

RECORD — starts recording

PLAY — starts playback

SEARCH — fast winds/rewinds tape

STOP/OPEN

— opens the cassette compartment

— stops the tape

PAUSE — pauses playback or recording

⑦ **OPEN•CLOSE** - press to open/close CD door

⑧ **DBB selector** — Switches the bass enhancement on / off

⑨ **VOLUME** — adjusts volume level

⑩ **Band selector** — selects wavebands

⑪ **Navigation controls**

PRESET -, + — selects a preset tuner station (down, up)

— stops CD playback;

— erases a CD programme

SEARCH —

CD: — searches back and forward within a track;

— skips to the beginning of a current track/ previous/ later track

Tuner: tunes to radio stations (down, up).

MODE — selects different play modes:

e.g. **REPEAT** or **SHUFFLE** (random) order

▶II — starts or pauses CD playback

⑫ **PROGRAM** —

CD: programmes tracks and reviews the programme;

Tuner: programmes preset radio stations

⑬ **Display** — shows the status of the set

CONTROLS

BACK PANEL

⑭ **Telescopic aerial** — improves FM reception

⑮ **AC MAINS** — inlet for mains lead

⑯ **Battery compartment** — for 6 batteries, type R-20, UM1 or D-cells

REMOTE CONTROL

① **VOLUME** +, - — adjusts volume level (up, down)

② **SHUFFLE** — plays all CD tracks in random order

③ **▶II** — starts/ pauses CD playback

④ **SEARCH** — searches backwards/ forwards within a track

⑤ **PRESET** — selects a preset radio station (up, down)

⑥ **TUNING** — tunes to tuner stations (down, up)

⑦ — stops CD playback;
— erases a CD programme

⑧ — skips to the beginning of a current track previous/ subsequent track

⑨ **REPEAT** — repeats a track /programme/ entire CD

CAUTION

Use of controls or adjustments or performance of procedures other than herein may result in hazardous radiation exposure or other unsafe operation.

IMPORTANT!

For users in the U.K.: please follow the instructions on the upper righthand-side.

BASIC FUNCTIONS

MAINS SUPPLY

Whenever convenient, use the mains supply to conserve battery life. Make sure you remove the power plug from the set and wall socket before inserting batteries.

Batteries (not included)

¥ Insert 6 batteries, type **R-20**, **UM-1** or **D-cells**, (preferably alkaline) with the correct polarity.

Remote control (See [A])

¥ Insert 2 batteries, type **AAA**, **R03** or **UM4** (preferably alkaline).

Incorrect use of batteries can cause electrolyte leakage and will corrode the compartment or cause the batteries to burst.

¥ *Do not mix battery types: e.g. alkaline with carbon zinc. Only use batteries of the same type for the set.*

• *When inserting new batteries, do not try to mix old batteries with the new ones.*

¥ **Batteries contain chemical substances, so they should be disposed of properly.**

Using AC Mains

1 Check if the mains supply, as shown on the **type plate located on the bottom of the set**, corresponds to your local mains supply. If it does not, consult your dealer or service centre.

2 If your set is equipped with a voltage selector, adjust the selector so that it matches with the local mains.

3 Connect the mains lead to the wall socket.

4 To disconnect the mains supply, unplug the set from the wall socket.

Auto-Standby mode

When a CD has reached the end of playback and remains in the stop position for more than 15 minutes, the set will switch off automatically to save mains.

When in pause position for 5 minutes, the CD playback will stop automatically. 15 minutes later, the set switches off.

The type plate is located on the bottom of the set.

BASIC FUNCTIONS

Switching on and off and selecting function

1 Press **STANDBY** on the set to switch on.

2 Press **Source selector** once or more to select: **CD**, **TUNER**, **AUX** or **TAPE** function.

3 Press to switch off the set.

Helpful hints:

— *To change from TAPE to CD, TUNER or AUX function, or when you are switching off the set: first, make sure you press the tape STOP key to end playback and all the cassette keys are released.*

— *The tone, sound settings, tuner presets and the volume level (up to a maximum volume level of 20) will be retained in the set's memory.*

Volume adjustment

¥ Adjust the volume with the **VOLUME** control.
→ Display shows the volume level and a number from 0-32. (See [2])

Bass adjustment

There are three **DBB** (Dynamic Bass Boost) options:

— **Off:** no bass enhancement

— **DBB1:** moderate bass enhancement

— **DBB2:** strong bass enhancement

¥ Press **DBB Selector** once or more to select your option.

→ DBB1,2 appears if DBB is activated.

DIGITAL TUNER

DIGITAL TUNER

Tuning to radio stations

- 1 Press \odot to on, then press **Source selector** to select **TUNER**.
— **LU** is displayed briefly and then the radio station frequency, waveband and, if programmed, a preset number are shown. (See [3])
 - 2 Press **Band selector** once or more to select your waveband.
 - 3 Press and hold \lll or \ggg until the frequency in the display starts running.
→ The radio automatically tunes to a station of sufficient reception. Display shows **SEARCH** during automatic tuning.
 - 4 Repeat steps 2-3 if necessary until you find the desired station.
- ¥ To tune to a weak station, press \lll or \ggg briefly and repeatedly until you have found optimal reception.

To improve radio reception:

- ¥ For **FM**, extend, incline and turn the telescopic aerial. Reduce its length if the signal is too strong.
- ¥ For **MW/LW**, the set uses a built-in aerial. Direct this aerial by turning the whole set.

Programming radio stations

You can store up to a total of 30 radio stations in the memory (20FM, 5MW and 5LW), manually or automatically (Autostore).

Manual programming

- 1 Tune to your desired station (see **Tuning to radio stations**).
- 2 Press **PROGRAM** to activate programming.
- 3 Press **PRESET -**, **+** (on the remote control \blacktriangle , \blacktriangledown) once or more to allocate a number from 1 to 20 for FM, 1 to 5 to MW and 1 to 5 for LW.
- 4 Press **PROGRAM** to confirm.
- 5 Repeat steps 1-4 to store other stations.

Helpful hints: You can erase a preset station by storing another frequency in its place.

CD PLAYER

Autostore

Autostore automatically starts programming radio stations from preset 1. Available stations are programmed in order of waveband reception strength: FM, followed by MW/LW. Any previous presets e.g. manually programmed will be erased.

¥ Press **PROGRAM** for 4 seconds or more to activate autostore programming.

→ Display: **auto**, **PROG** flashes.

After all stations are stored, the first autostore preset station will then automatically play.

To listen to a preset or autostore station

Press the **PRESET -**, **+** (on the remote control \blacktriangle , \blacktriangledown) buttons once or more until the desired preset station is displayed.

CD PLAYER

Playing a CD

This CD player plays Audio Discs including CD-Recordables and CD-Rewritables.

- 1 Press \odot to on, then **Source Selector** to select **CD**.
- 2 Insert a CD with the printed side facing up and close the CD door.
→ **READ** is displayed as the CD player scans the contents of a disc, and then the total number of tracks and playing time are shown. (See [4])
- 3 Press \ggg to start playback.
- 4 To pause playback press \ggg . Press \ggg again to resume play.
- 5 To stop CD playback, press \blacksquare .

Helpful hints: CD play will also stop when:

- the CD door is opened
- the CD has reached the end
- you select tuner, AUX or tape source.

CD PLAYER

Selecting a different track

- ¥ Press \lll or \ggg (on the remote control \blacktriangleleft or \blacktriangleright) once or repeatedly until the desired track number appears in the display.
- ¥ In the pause/stop position, press \ggg to start playback.

Finding a passage within a track

- 1 Press and hold \lll or \ggg (or press **SEARCH** \lll , \ggg on the remote control).
→ The CD is played at high speed and low volume.
- 2 When you recognize the passage you want, release \lll or \ggg to resume normal playback.

Different play modes: SHUFFLE and REPEAT

(See [5] - [7])

You can select and change the various play modes before or during playback, and combine the modes with **PROGRAM**.

- shuffle** — tracks of the entire CD/program are played in random order
- shuffle** and **repeat all** — repeats the entire CD/programme continuously in random order
- repeat all** — repeats the entire CD/program
- repeat** — plays the current track continuously

- 1 To select play mode, press **MODE (SHUFFLE or REPEAT)** on the remote control) once or more.
- 2 Press \ggg to start playback if in the stop position.
- 3 To select normal playback, press **MODE** repeatedly until the various modes are no longer displayed.
—You can also press \blacksquare to cancel your play mode.

Programming track numbers

In the stop position, select and store your CD tracks in the desired sequence. Up to 20 tracks can be stored in the memory.

- 1 Press \lll or \ggg (on the remote control \blacktriangleleft or \blacktriangleright) to select your desired track number.
- 2 Press **PROGRAM**.
→ If you attempt to program without first selecting a track number, **NOSE** is shown.
- 3 Repeat steps 1-2 to select and store all desired tracks.
→ Display: **FULL** if you try to programme more than 20 tracks.

CASSETTE RECORDER

Helpful hints: During normal playback, you can press **PROGRAM** to add a current track to your program list.

Reviewing the programme

In the stop position, press and hold **PROGRAM** until the display shows all your stored track numbers in sequence.

Erasing a programme

You can erase the contents of the memory by:

- ¥ opening the CD door;
- ¥ selecting **TUNER**, **AUX** or **TAPE** sound sources;
- ¥ pressing \blacksquare twice during playback or once in the stop position.
→ **CLR** is displayed briefly and **PROG** disappears.

AUX (audio cable not included)

This 3.5mm socket allows you to connect other audio equipment to your system e.g. a MP3-CD player.

- 1 Press \odot to on, then **Source Selector** to select **AUX**.
→Display shows: **AUH**.
- 2 Use an audio cable to connect the **AUX** socket to the **LINE OUT**/headphone socket on your external equipment.
- 3 To avoid noise distortion, turn down the volume on your external equipment.
- 4 To adjust the sound and volume, use the sound controls on your external equipment and the AZ2060.

CASSETTE RECORDER

Cassette playback

- 1 Press \odot to on, then **Source Selector** to select **TAPE**.
→ Display: shows **TAPE** throughout tape operation.
 - 2 Insert a cassette and close the door.
 - 3 Press **PLAY** \blacktriangleleft to start playback.
 - 4 To pause, press **PAUSE II**. Press again to resume.
 - 5 Press **SEARCH** \lll or \ggg to fast wind the tape.
 - 6 To stop the tape, press **STOP/OPEN** \blacksquare .
- ¥ The keys are automatically released at the end of a tape, except if **PAUSE II** has been activated.

CASSETTE RECORDER

GENERAL INFORMATION ON RECORDING

- ¥ Recording is permissible insofar as copyright or other rights of third parties are not infringed.
- ¥ For recording, use only NORMAL type cassettes (IEC type I) on which the tabs have not yet been broken. This deck is not suited for recording on CHROME (IEC II) or METAL (IEC IV) type cassettes.
- ¥ The best recording level is set automatically. Altering the **VOLUME** or **DBB** controls will not affect the recording.
- ¥ To protect a tape from accidental erasure, break out the tabs. If you wish to record again, cover the tabs with a piece of adhesive tape.

CD Synchro Start recording

- 1 Select CD function.
- 2 Insert a CD and if desired, programme track numbers.
- 3 Open the cassette door.
- 4 Insert a suitable tape into the cassette deck and close the door.
- 5 Press **RECORD** ● to start recording.
 - Playing of the CD/program starts automatically from the beginning. You don't need to start the CD player separately.
 - To select and record a particular passage within a CD track:
 - ¥ Press ◀◀ or ▶▶. Release the control when you recognize the passage you want.
 - ¥ To pause CD playback, press ▶II.
 - ¥ Recording starts from this exact point in the track when you press **RECORD** ●.
- 6 To pause recording, press **PAUSE** II.
Press **PAUSE** II again to resume recording.
- 7 To stop recording, press **STOP/OPEN** ■▲.

Recording from the Radio

- 1 Tune to the desired radio station (see Tuning to radio stations).
- 2 Follow steps 3-7, under CD Synchro Start recording.

MAINTENANCE & SAFETY

Maintenance & Safety

CD player and CD handling (See 8)

- ¥ If the CD player cannot read CDs correctly, use a cleaning CD to clean the lens before taking the set to repair.
- ¥ The lens of the CD player should never be touched!
- ¥ Sudden changes in the surrounding temperature can cause condensation on the lens of your CD player. Playing a CD is then not possible. Do not attempt to clean the lens but leave the set in a warm environment until the moisture evaporates.
- ¥ Always close the CD door to avoid dust on the lens.
- ¥ To clean the CD, wipe in a straight line from the centre towards the edge using a soft, lint-free cloth. Do not use cleaning agents as they may damage the disc.
- ¥ Never write on a CD or attach any stickers to it.

Safety Information

- ¥ Don't expose the set, batteries, CDs or cassettes to humidity, rain, sand or excessive heat.
- ¥ Clean the set with a dry cloth. Don't use any cleaning agents containing alcohol, ammonia, benzene or abrasives as these may harm the set.
- ¥ Place the set on a hard and flat surface so that the system does not tilt. Make sure there is good ventilation to prevent the set overheating.
- ¥ The mechanical parts of the set contain self-lubricating bearings and must not be oiled or lubricated.

Tape deck maintenance (See 9)

To ensure quality recording and playback of the tape deck, clean parts (A), (B) and (C) as shown, once a month. Use a cotton bud slightly moistened with alcohol or a special head cleaning fluid to clean the deck.

- 1 Open the cassette door.
- 2 Press **PLAY** ◀ and clean the roller (C).
- 3 Press **PAUSE** II and clean the heads (A), and the capstan (B).
- 4 After cleaning, press **STOP/OPEN** ■▲.

TROUBLESHOOTING

WARNING

Do not open the set as there is a risk of electric shock! Under no circumstances should you try to repair the set yourself, as this will invalidate the guarantee.

If a fault occurs, first check the points listed below before taking the set for repair.

If you are unable to remedy a problem by following these hints, consult your dealer or service centre.

Remote control does not function properly

- Batteries exhausted/ incorrectly inserted
- ¥ Insert (fresh) batteries correctly
- Distance/ angle between the set too large
- ¥ Reduce the distance/ angle

No sound /power

- Volume not adjusted
- ¥ Adjust the VOLUME
- Power cord not securely connected
- ¥ Connect the AC power cord properly
- Batteries dead/ incorrectly inserted
- ¥ Insert (fresh) batteries correctly
- Headphones connected to the set
- ¥ Disconnect headphones

Severe radio hum or noise

- Electrical interference: set too close to TV, VCR or computer
- ¥ Increase the distance

Poor radio reception

- Weak radio signal
- ¥ FM: Adjust the FM telescopic aerial

Poor cassette sound quality

- Dust and dirt on the heads, etc.
- ¥ Clean deck parts, see Maintenance
- Use of incompatible cassette types (METAL or CHROME)
- ¥ Only use NORMAL (IEC I) for recording

Recording does not work

- Cassette tab(s) may be broken
- ¥ Apply adhesive tape over the missing tab space

no cd / Err indication

- CD badly scratched or dirty
- ¥ Replace/ clean CD, see Maintenance
- Laser lens steamed up
- ¥ Wait until lens has cleared
- CD-R(W) is blank/ not finalized
- ¥ Use a finalized CD-R(W)
- CD-ROM disc inserted/ CD contains non-audio files
- ¥ Use CD Audio discs only/ press ◀◀ or ▶▶ once or more to skip to a CD audio track instead of the data files

The CD skips tracks

- CD damaged or dirty
- ¥ Replace or clean CD
- SHUFFLE or PROGRAM is active
- ¥ Switch off SHUFFLE / PROGRAM

Environmental information

We have done our best to reduce the packaging and make it easy to separate into 3 materials: cardboard, expandable polystyrene, polyethylene.

Your set consists of materials which can be recycled if disassembled by a specialized company. Please observe the local regulations regarding the disposal of packaging, dead batteries and old equipment.

This apparatus is fitted with an approved 13 Amp plug. To change a fuse in this type of plug proceed as follows:

- ✘ Remove fuse cover and fuse.
- ✘ Fix new fuse which should be a BS1362 5A, A.S.T.A. or BSI approved type.
- ✘ Refit the fuse cover.

If the fitted plug is not suitable for your socket outlets, it should be cut off and an appropriate plug fitted in its place.

If the mains plug contains a fuse, this should have a value of 5A. If a plug without a fuse is used, the fuse at the distribution board should not be greater than 5A.

Note: The severed plug must be disposed to avoid a possible shock hazard should it be inserted into a 13A socket elsewhere.

How to connect a plug

The wires in the mains lead are coloured in accordance with the following code:

BLUE — "NEUTRAL" ("N") and BROWN — "LIVE" ("L").

As these colours may not correspond with the colour markings identifying the terminals in your plug, proceed as follows:

- ✘ The BLUE wire must be connected to the terminal which is marked with the letter "N" or coloured BLACK.
- ✘ The BROWN wire must be connected to the terminal which is marked with the letter "L" or coloured RED.
- ✘ Do not connect either wires to the earth terminal in the plug which is marked by the letter "E" or by the safety earth symbol or coloured green or green-and-yellow.

Before replacing the plug cover, make certain that the cordgrip is clamped over the sheath of the lead — not simply over the two wires.

Copyright in the U.K.

Recording and playback of material may require consent. See Copyright Act 1956 and The Performer's Protection Acts 1958 to 1972.

This product complies with the radio interference requirements of the European Union.

Ce matériel satisfait aux impératifs de brouillage radio de la Communauté Européenne.

Este aparato satisface las normas relativas a la interferencia radioeléctrica de la Comunidad Europea.

Dieses Produkt entspricht den Funkentstörvorschriften der Europäischen Union.