

# MP3-CD Soundmachine

AZ1856

Register your product and get support at  
[www.philips.com/welcome](http://www.philips.com/welcome)

User Manual



# PHILIPS

1

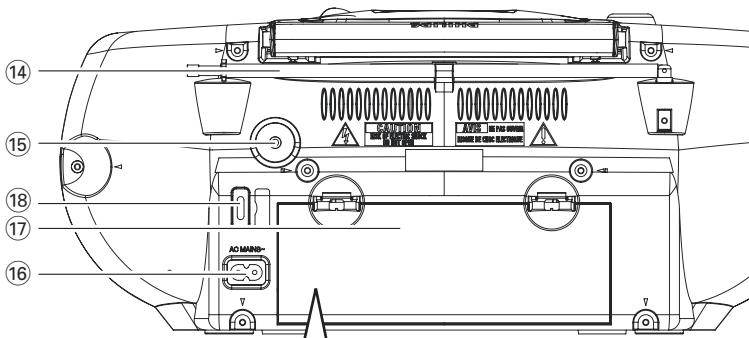
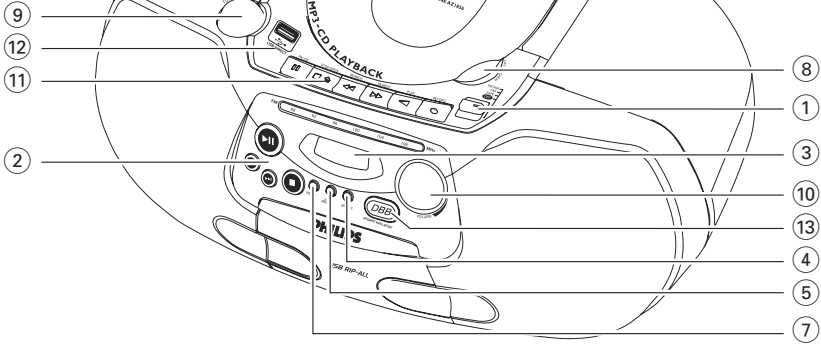

6 x R14 • UM-2 • C-CELLS

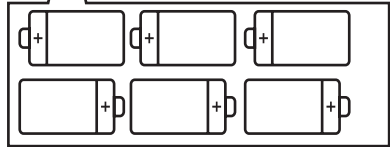

3



9



4



10



5

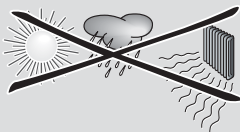

6



7

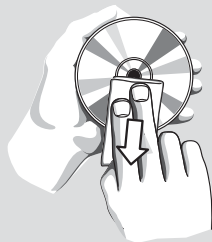

8

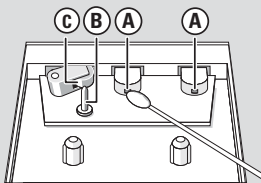

11

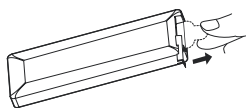

Removing the insulation plastic tab

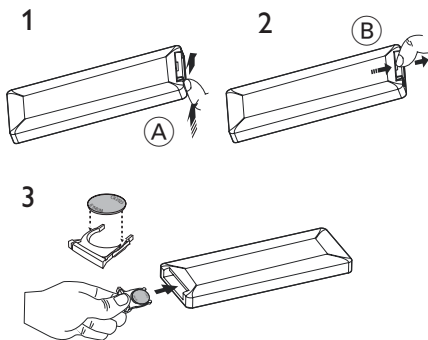

12

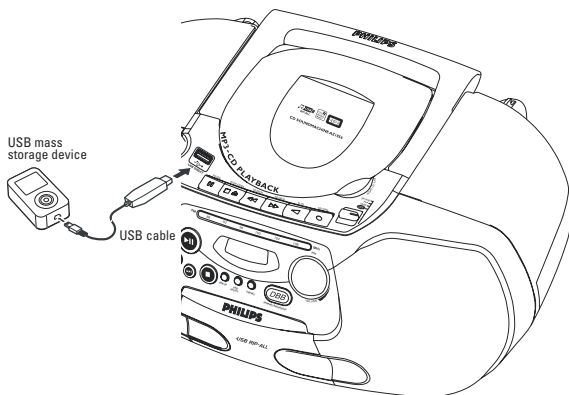

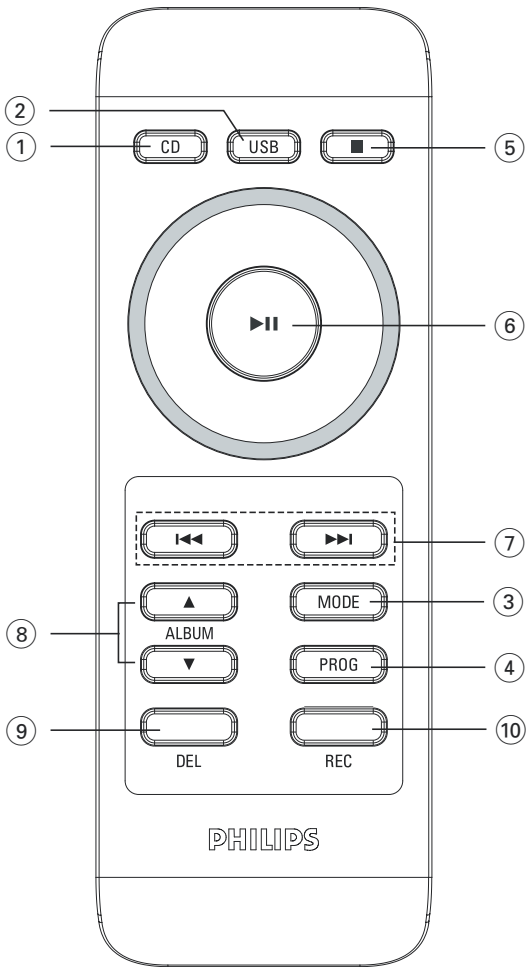

## English

**Congratulations on your purchase and welcome to Philips!**

**To fully benefit from the support that Philips offers, register your product at [www.philips.com/welcome](http://www.philips.com/welcome).**

### IMPORTANT!

- **PLEASE NOTE THAT THE VOLTAGE SELECTOR LOCATED AT THE REAR OF THIS SYSTEM IS PRESET AT 220V FROM THE FACTORY. FOR COUNTRIES THAT OPERATE AT 110V-127V PLEASE ADJUST TO 110V-127V BEFORE YOU SWITCH ON THE SYSTEM.**

### Supplied accessories

- AC power cord
- Remote control

### Top and front panels (See 1)

- ① **Source selector: DISC/USB, FM, TAPE, OFF**
  - selects CD/MP3-CD (or USB mode), or radio
  - switches off the set
- ② **▶|** – starts or pauses disc/USB playback  
**◀◀ ▶▶**
  - **For disc/ USB play:**
    - skips to the beginning of a current/ previous/ later track
    - fast searches backwards and forwards within a track
      - – stops disc/USB playback;
        - erases a program
- ③ **Display** – shows disc/USB play functions
- ④ **USB REC** – copy one file or all files of a disc to an external portable USB storage device/MP3 player
- ⑤ **USB DELETE** – delete one file or all files of an external portable USB storage device/MP3 player
- ⑥ **iR** – infrared sensor for remote control
- ⑦ **USB/CD** – enters disc or USB mode
- ⑧ **LIFT TO OPEN** – opens/closes the DISC door
- ⑨ **TUNING** – tunes to radio stations
- ⑩ **VOLUME** – adjusts volume level
- ⑪ Cassettes keys

## Controls / Power Supply

- ||** – interrupts recording or playback
- ▲ – stops the tape and to open the cassette holder.
- ◀◀ / ▶▶ – fast winds/rewinds the tape
- ◀ – starts playback
- – starts recording
- ⑫ **USB DIRECT** – connects an external USB mass storage device
- ⑬ **DBB** – for a more vivid bass response

### Back panel (See 1)

- ⑭ **Telescopic antenna** – improves FM reception
  - ⑮ **📎** – 3.5 mm stereo headphone socket
- Helpful hints:** *The speakers will be muted when headphones are connected to the set.*
- ⑯ **AC~ MAINS** – inlet for power cord
  - ⑰ **Battery door** – open to insert 6 x 1.5V **R-14/ UM2/ C-cells**
  - ⑱ **Voltage selector** – adjusts and matches to the local voltage 110/220V before plugging in the set

### Remote control (See 2)

- ① **CD** – enters disc mode
- ② **USB** – enters USB mode
- ③ **MODE** – selects different play modes: e.g. **REP, REP ALL, SHUF REP ALL** or **SHUF** (random order)
- ④ **PROG** – programs tracks and reviews the program
- ⑤ ■ – stops DISC/USB playback;
  - erases a program
- ⑥ **▶|** – starts/ pauses DISC/USB playback
- ⑦ **◀◀ ▶▶**
  - For disc/ USB play:**
    - fast searches back and forward
    - skips to the beginning of a current track/ previous/ later track
- ⑧ **ALBUM ▲ / ▼**
  - For MP3-CD/USB play:** selects albums
- ⑨ **DEL** – deletes one file or all files stored on the external USB device
- ⑩ **REC** – copy one file or all files of a disc to an external portable USB storage device/MP3 player

# Power Supply

---

## Power Supply

### IMPORTANT!

- **THE SYSTEM IS EQUIPPED WITH A VOLTAGE SELECTOR, SET THE VOLTAGE SELECTOR TO MATCH THE LOCAL POWER LINE.**

Whenever convenient, use the power supply cord if you want to conserve battery life. Make sure you remove the plug from the set and wall outlet before inserting batteries.

### Batteries

#### Main set (See [1](#))

- Insert **6** batteries, type **R-14, UM2** or **C-cells** (not included, preferably alkaline) with the correct polarity.

#### Remote control

### Important!

- **Before using the remote control, remove the insulation plastic tab as shown in figure [11](#).**
- **If the remote control does not function correctly or the operating range is reduced, replace the battery with a new (CR2025) type battery**

- 1 Press and hold the latch (A) in the direction as shown in figure [11](#).
  - 2 Simultaneously, pull the battery tray (B) out.
  - 3 Replace a new battery, and fully insert the battery tray back to the original position.
- Incorrect use of batteries can cause electrolyte leakage and will corrode the compartment or cause the batteries to burst:
  - Do not mix battery types: e.g. alkaline with carbon zinc. Only use batteries of the same type for the set.
  - When inserting new batteries, do not try to mix old batteries with the new ones.
  - Remove the batteries if the set is not to be used for a long time.

**Batteries contain chemical substances, so they should be disposed of properly.**

### Using AC power

- 1 Check if the power/mains voltage, **as shown on the type plate located on the bottom of the set**, corresponds to your local power supply. If it does not, consult your dealer or service center.
  - 2 Connect the power cord to the **AC~ MAINS** inlet and the wall socket. The set is now ready for use.
  - 3 To switch the set off completely, withdraw the power cord from the wall socket.
  - 4 Install the unit near the AC outlet and where the AC power plug can be easily reached.
- Disconnect the power cord from the wall socket to protect your set during heavy thunderstorms. Children could seriously injure themselves as the free end of the cable may still be live if only the connector is removed from the MAINS socket at the back of the unit.

**The type plate is located on the bottom of the set.**

### Auto power saving

- When the **source selector** is adjusted to **DISC/USB** and the set is in the PAUSE position for **5** minutes, the set will be auto switched to the stop position to save power.

### Helpful hints:

- To avoid unnecessary energy consumption, always adjust the **source selector** to **OFF** after using the set.

## CAUTION

**Use of controls or adjustments or performance of procedures other than herein may result in unsafe operation.**

## Basic functions

### Switching on/off the set

- 1 To switch on, adjust the **source selector** to **DISC/USB, FM** or **TAPE** as desired.
- 2 To switch off, adjust the **source selector** to **OFF**.

### Adjusting sound

Adjust the sound with the **VOLUME** and **DBB** controls.

## Radio reception

- 1 Push the **source selector** to **FM**
- 2 Turn **TUNING** to tune in a radio station.
- 3 To switch off the radio, adjust the **source selector** to **OFF**.

### Helpful hints:

#### To improve reception

- For **FM**, extend, incline and turn the telescopic antenna. Reduce its length if the signal is too strong.

## Playing a tape

1. Set the source selector to **TAPE**.
2. Press **■ ▲** to open the cassette holder.
3. Insert a recorded cassette.
4. Press **◀** and playback will start.
5. Adjust the sound using the **VOLUME** and **DBB** controls.
6. For brief interruptions, press **II**. Press **II** again to resume playback.
7. By pressing **◀◀** or **▶▶**, fast winding of the tape is possible in both directions.
8. To stop playback, press **■ ▲**  
→The keys are automatically released at the end of the tape.
9. Set the source selector to **OFF** position (with the cassette keys released) to switch off the set.

### Note :

- During playback, the keys are automatically released at the end of a tape and the set is switched off (unless **PAUSE** mode **II** has been activated.)
- During fast forwarding/rewinding, the keys will not be released at the end of a tape. To switch off the set, make sure the cassette keys are also released.

## Cassette recording

### General information on cassette recording

- Recording is permissible insofar as copyright or other rights of third parties are not infringed.
- This deck is not suitable for recording on **CHROME** (IEC II) or **METAL** (IEC IV) type cassettes. For recording you should use **NORMAL** type cassettes (IEC I) on which the tabs have not been broken.
- Check and tighten slack tape before use with a pencil to avoid jamming the deck mechanism.
- The recording level is set automatically.



## Note:

- No recording will take place during the 7 seconds in the beginning of the tape.
- To prevent the accidental erasure of a recording, keep the cassette side to be safeguarded in front of you and break out the left tab. Recording on this side is no longer possible.

---

## Recording from radio

1. Set the source selector to **FM**.
2. For radio, tune to the desired radio station using the **TUNING** knob.
3. Press **■▲** to open the cassette holder.
4. Insert a blank tape.
5. Press **●** to start recording.
6. For brief interruptions, press **||**. To resume recording, press **||** again.
7. To stop recording, press **■▲**.

---

## Synchro start CD/USB recording

1. Set the source selector to **DISC/USB**.
2. Insert a CD/USB device and if desired, programme disc track numbers.  
→ Press **USB/CD** to select CD/USB mode
3. Press **■▲** to open the cassette holder.
4. Insert a blank cassette.
5. Press **●** to start recording.  
→ Playing of the CD programme starts automatically from the beginning of the programme.
6. For brief interruptions, press **||**. To resume recording, press **||** again.
7. To stop recording press **■▲**

### To select and record a particular passage within a track

1. Press and hold **◀◀** or **▶▶** on the set to select a passage.
2. Put the CD player in **||** position at the selected passage.  
→ Recording will start from this exact point when you press **●**.
3. Press **▶||** to start recording.

## About MP3

The music compression technology MP3 (MPEG1 Audio Layer 3) significantly reduce the digital data of an audio CD while maintaining CD quality sound.

- **Getting MP3 files:** you can either download legal music files from the internet to your computer hard disc, or create such files by converting audio CD files in your computer through appropriate encoder software. (128kbps bit rate or higher is recommended for MP3 files.)
- **Creating a MP3 CD:** burn the music files from your computer hard disc on a CDR or CDRW using your CD burner.

### Helpful hints:

- Make sure that the file names of the MP3 files end with **.mp3** or **.wma**.
- Number of albums: maximum 500
- Number of tracks: maximum 1000
- The length of file names affects the number of tracks for playback. With shorter file names, more files can be burned on a disc.

---

## Playing a disc

This player plays Audio Discs including CD-R/CD-RW, MP3 CD and WMA. Do not try to play a CD-ROM, CD-I, CDV, VCD, DVD or computer CD.

### IMPORTANT!

- CDs encoded with **copyright protection technologies** by some record companies may be unplayable by this product.
  - DRM-protected WMA disc is not supported.
- 1 Adjust the **source selector** to **DISC/USB**.  
→ Display shows **u5b** (see [3](#)), or **na** if no USB device available (see [4](#))

# MP3-CD/ CD Player

---

- 2 Press **USB/CD** to enter CD mode if USB is displayed.  
→ Display will show *c d* (See [5]). or *no disc in* (See [6])
  - 3 Open the disc door.
  - 4 Insert a disc with the printed side facing up and press the disc door gently to close.  
→ Display: The total number of tracks appears.  
→ The disc scanning of MP3-CD may run longer than audio CD.
  - 5 Press **▶II** to start playback.  
→ Display: ▶ and the current track number.
- For MP3-CD/WMA only:**
- The current track number "XXXX" and file format will be displayed (See [7]).
  - 6 To pause playback press **▶II**.  
→ Display: ▶ and the current track number flash.
  - 7 Press **▶II** again to resume playback.
  - 8 To stop playback, press **■**.

## Helpful hints:

The disc playback will also stop when:

- you open the disc compartment door;
- you select **FM** or **OFF** position;
- the disc has reached the end of the playback.

---

## Selecting a different track

- Press **◀◀** or **▶▶** once or repeatedly until the desired track number appears in the display.

**For MP3-CD/WMA:** First press **ALBUM ▲ / ▼** once or more to find your album.

- In the pause/stop position, press **▶II** to start playback.

---

## Finding a passage within a track

- 1 During playback, press and hold down **◀◀** or **▶▶**.  
→ The disc is played at high speed and low volume.
- 2 When you recognize the passage you want, release **◀◀** or **▶▶**.  
→ Normal playback resumes.

---

## Programming tracks

You may store up to 40 tracks in the desired sequence. If you like, store any track more than once.

- 1 In the stop position, press **PROG** to start programming.  
→ Display shows *p U 1* indicating the start of the program. And the track number "XXXX" flashes (See [8]).
- 2 Press **◀◀** or **▶▶** to select your desired track number.

### For MP3-CD/WMA:

First press **ALBUM ▲ / ▼** once or more to find your album.

- 3 Press **PROG** to store the desired track.  
→ Display shows *p U 2*, indicating the next program location available.
- 4 Repeat steps **2** to **3** to select and store all desired tracks.
- 5 Press **▶II** to play the program.

### To review your program

In the stop position, press and hold **PROG** 3 seconds.

→ The display shows all the stored tracks in sequence.

### Helpful hints:

- Display shows *p U 1* if no track is programmed.
- If you try to store more than 20 tracks, no track can be stored and the display will show *FULL*.

## To erase a program

You can erase a program by

- pressing **■** (twice during playback or once in the stop position)
  - selecting **FM** or **OFF** position;
  - opening the disc door.
- Display: **PROG** disappears.

## Selecting different play modes

You can select and change the various play modes before or during playback, and combine play modes with **PROG**.

**REP** – plays the current track continuously.

**REP ALL** – plays the entire disc/program continuously.

**SHUF REP ALL** – plays all tracks continuously in random order

**SHUF** – plays all tracks in random order.

- 1 To select play modes, press **MODE** once or more.
- 2 Press **▶||** to start playback if in the stop position.
- 3 To select normal playback, press **MODE** repeatedly until the various modes are no longer displayed.  
– You can also press **■** to cancel your play modes.

## Using USB connectivity

- AZ1856 is fitted with a USB port in the top panel, offering a plug and play feature which allows you to play, from your AZ1836, digital music and spoken contents stored on a USB mass storage device.
- Using a USB mass storage device, you can also enjoy all the features offered by AZ1856 which are explained and instructed in the sections of disc operation.

### Compatible USB mass storage devices

With the AZ1856, you can use

- USB flash memory (USB 2.0 or USB 1.1)
- *USB flash player (USB 2.0 or USB 1.1)*
- USB device which requires driver installation under Windows XP is not supported.

### Note:

In some USB flash players (or memory devices), the stored contents are recorded using copyright protection technology. Such protected contents will be unplayable on any other devices (such as AZ1856 device).

### Supported formats:

- USB or memory file format FAT12, FAT16, FAT32 (sector size: 512 - 4096 bytes)
- MP3 bit rate (data rate): 32-320 kbps and variable bit rate
- WMA v9 or earlier
- Directory nesting up to a maximum of 8 levels
- Number of albums: maximum 500
- Number of tracks: maximum 1000
- ID3 tag v2.0 or later
- File name in Unicode UTF8 (maximum length: 128 bytes)

### The system will not play or support the following:

- Empty albums: an empty album is an album that does not contain MP3/WMA files, and will not be shown in the display.
- Non-supported file formats are skipped. This means that e.g.: Word documents .doc or MP3 files with extension. dlf are ignored and will not be played.
- AAC, WAV, PCM.NTFS audio files
- DRM protected WMA files
- WMA files in Lossess format

# USB Connection

---

## Playing a USB mass storage device

- 1 Make sure that your AZ1856 is being powered by AC mains or specified batteries.
- 2 Adjust the **source selector** to **DISC/USB**.
  - Display shows *u5b* (see [3]), or *n5* if no USB device available (see [4]).
- 3 Press **USB/CD** to enter USB mode if USB is NOT displayed.
  - Display will show *u5b* (see [3]).
- 4 As shown in figure [12], plug a compatible USB mass storage device to AZ1856's USB port marked . If needed, use a suitable USB cable to connect between the device and AZ1856's USB port.
  - The device will automatically power on.
  - If the device is not powered on, turn on the power manually, then re-connect it.
    - AZ1856's display shows USB and the total number of playable audio files (Max. displayed track number is 1000) stored on the device.
- 5 Press **▶||** on your AZ1856 to start play.
  - AZ1856's display will show USB and share the display information illustrated in the disc operation.

### Helpful hints:

– Make sure that file names of MP3 files end with *.mp3*, and the file names of WMA files end with *.wma*.

– For DRM protected WMA files, use Windows Media Player 10 (or later) for conversion. Visit [www.microsoft.com](http://www.microsoft.com) for details about Windows Media Player and WM DRM (Windows Media Digital Rights Management).

– For USB device playing, if the display shows "OL", it means that the USB device is electrically overloading AZ1856. You need to change a USB device.

## CD/Tape/Tuner Ripping

AZ1856 allows you to copy the music files or spoken contents of a disc/tape/station to the external USB device..

### CD ripping

- 1 Adjust the **source selector** to **DISC/USB**.
- 2 Insert a disc (audio CD or MP3 or WMA).
- 3 Press **USB/CD** to enter CD mode if USB is displayed.
- 4 Plug a USB mass storage device.
- 5a Press once **USB REC** (or **REC** on the remote) to record one file. *REC* appears, flashing.
- 5b Press twice **USB REC** (or **REC** on the remote) to record all files. *REC* and *ALL* appear.
  - Disc playback will start automatically from the beginning of the selected track(s).
- 6 To stop recording, first press **■**, then unplug the USB device.
  - During MP3 and WMA recording, make sure the playback of the file you want to record is wholly completed before manually stop recording. Or any part of the file will not be recorded.
  - During recording, if the memory of the USB device runs out, playback will not continue.

### Tape/Tuner ripping

- 1 Adjust the **source selector** to **TAPE** or **FM**.
- 2 Plug a USB mass storage device.
- 3 Select the music file(s) (in sequence), or tune to a desired station you want to record.
- 4 Press once **USB REC** (or **REC** on the remote) and *REC* appears flashing
  - Tape/tuner ripping begins.
  - Press **||** if you want to interrupt tape ripping.
- 5 Press **■** if you want to stop ripping.



# Safety & Maintenance (See 10)

## Safety information

- Place the set on a hard, flat and stable surface so that the system does not tilt.
- Where the MAINS plug or an appliance coupler is used as the disconnect device, the disconnect device shall remain readily operable.
- Do not expose the set, batteries, CDs to humidity, rain, sand or excessive heat caused by heating equipment or direct sunlight.
- The apparatus shall not be exposed to dripping or splashing.
- Adequate ventilation with a minimum gap of 15 cm between the ventilation holes and surrounding surfaces is necessary to prevent heat build-up.
- The ventilation should not be impeded by covering the ventilation openings with items, such as newspapers, table-cloths, curtains, etc..
- No objects filled with liquids, such as vases, shall be placed on the apparatus.
- No naked flame sources, such as lighted candles, should be placed on the apparatus.
- The mechanical parts of the set contain self-lubricating bearings and must not be oiled or lubricated.
- To clean the set, use a dry cloth. Do not use any cleaning agents containing alcohol, ammonia, benzene or abrasives as these may harm the housing.

## Environmental information

All unnecessary packaging material has been omitted. The packaging can be easily separated into three materials: cardboard, polystyrene and plastic.

**Your set consists of materials which can be recycled if disassembled by a specialized company. Please observe the local regulations regarding the disposal of packaging, dead batteries and old equipment.**

## CD player and CD handling

- If the CD player cannot read CDs correctly, use a cleaning CD to clean the lens before taking the set to repair.
- The lens of the CD player should never be touched!
- Sudden changes in the surrounding temperature can cause condensation on the lens of your CD player. Playing a CD is then not possible. Do not attempt to clean the lens but leave the set in a warm environment until the moisture evaporates.
- Always close the CD door to avoid dust on the lens.
- To clean the CD, wipe in a straight line from the center towards the edge using a soft, lint-free cloth. Do not use cleaning agents as they may damage the disc.
- Never write on a CD or attach any stickers to it.

## Cassette recorder

- To ensure a good recording and playback of the tape deck, clean parts (A), (B) and (C) show in the diagram below, after approx. 50 hours of operation, or on average once a month. Use a cotton bud slightly moistened with alcohol or a special head cleaning fluid to clean the deck.
- Open the cassette holder by pressing ■▲.
- Press ◀ and clean the rubber pressure rollers (C).
- Press || and clean the magnetic heads (A) and also the capstans (B).
- After cleaning, press ■▲.
- Cleaning of the heads can also be done by playing a cleaning cassette through once.

# Troubleshooting

---

If a fault occurs, first check the points listed below before taking the set for repair.

If you are unable to remedy a problem by following these hints, consult your dealer or service centre.

**WARNING:** Do not open the set as there is a risk of electric shock. Under no circumstances should you try to repair the set yourself, as this will invalidate the guarantee.

## No sound/ power

---

- Volume not adjusted
- Adjust the VOLUME
- Power cord not securely connected
- Connect the AC power cord properly
- Batteries dead/ incorrectly inserted
- Insert (fresh) batteries correctly
- Disc contains non-audio files
- Insert a suitable disc or press ◀◀ or ▶▶ once or more skip to an audio track, instead of the data files.

## Display does not function properly/No reaction to operation of any of the controls

---

- Electrostatic discharge
- Switch off and unplug the set. Reconnect after a few seconds.

## ⏏ indication

---

- It is set in the USB mode.
- Press **CD/USB** to select CD mode.
- No disc inserted
- Insert a suitable disc
- Disc badly scratched or dirty
- Replace/clean CD (See Maintenance)
- CD-R(W) is blank or the disc is not finalized.
- Use a finalized CD-R(W)
- Laser lens steam up
- Wait until lens has cleared.

### Note:

**Make sure the CD is not encoded with Copyright protection technologies, as some do not conform to the Compact Disc standard.**

## The disc skips tracks

---

- Disc damaged or dirty
- Replace or clean disc
- Shuffle or program is active
- Switch off shuffle/program

## Sound skips during MP3 playback

---

- MP3 file made at compression level exceeding

320kbps

- Use a lower compression level to record CD tracks into MP3 format
- Disc damaged or dirty
- Replace or clean disc.

### Note:

**DRM-protected WMA disc is not supported. The USB device doesn't play on my AZ1856**

---

- It is not set in the USB mode.
- Press **CD/USB** to select USB mode.
- The device is not securely connected to AZ1856's USB direct.
- Re-connect the device, and make sure that the device is powered on.
- The device is not supported by AZ1856, or the audio file format stored on the device is not supported by AZ1856.
- Use a compatible device/ playable audio file format.

## The disc file cannot be recorded to the USB device

---

- You stop recording when the MP3 or WMA file you want to record is still playing.
- Stop recording only when the playback of MP3 or WMA file is wholly completed.
- The memory of the USB device runs out.
- Delete some unwanted files on the USB device to free some memory, or use another USB device of sufficient free memory to record.
- The name of a MP3 or WMA file on the disc is identical to the one of a file on the USB device.
- Change to a different name for the file on the USB device.

## Tape operation/recording

---

- Recording or playback cannot be made
- Clean deck parts, see "Maintenance".
- Use only NORMAL (IEC I) tape.
- Apply a piece of adhesive tape over the missing tab space.

Meet Philips at the Internet  
<http://www.philips.com>



AZ1856



Printed in China

PDCC-ZH/ZC-0729



