

CD Radio Cassette Recorder

AZ 1570

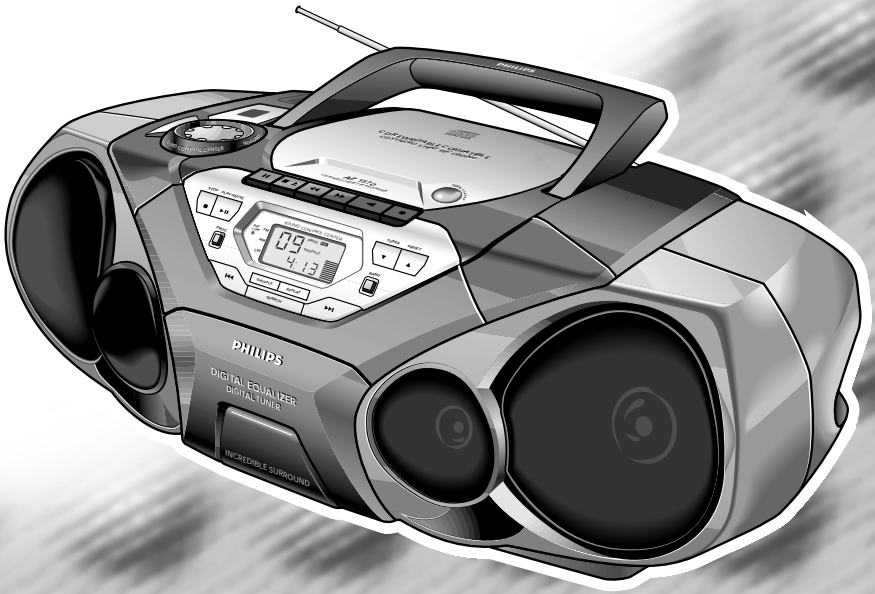

Toll Free Help Line

Ligne d'assistance en service libre
Línea de ayuda telefónica sin cargo

800-531-0039



Let's make things better.



PHILIPS

Return your Warranty Registration card today to ensure you receive all the benefits you're entitled to.

- Once your Philips purchase is registered, you're eligible to receive all the privileges of owning a Philips product.
- So complete and return the Warranty Registration Card enclosed with your purchase at once. And take advantage of these important benefits.

Warranty Verification

Registering your product within 10 days confirms your right to maximum protection under the terms and conditions of your Philips warranty.

Owner Confirmation

Your completed Warranty Registration Card serves as verification of ownership in the event of product theft or loss.

Model Registration

Returning your Warranty Registration Card right away guarantees you'll receive all the information and special offers which you qualify for as the owner of your model.

Know these safety symbols



This "bolt of lightning" indicates uninsulated material within your unit may cause an electrical shock. For the safety of everyone in your household, please do not remove product covering.



The "exclamation point" calls attention to features for which you should read the enclosed literature closely to prevent operating and maintenance problems.

For Customer Use

Enter below the Serial No. which is located on the bottom of the cabinet. Retain this information for future reference.

Model No. _____

Serial No. _____

WARNING: TO PREVENT FIRE OR SHOCK HAZARD, DO NOT EXPOSE THIS EQUIPMENT TO RAIN OR MOISTURE.

CAUTION: To prevent electric shock, match wide blade of plug to wide slot, and fully insert.

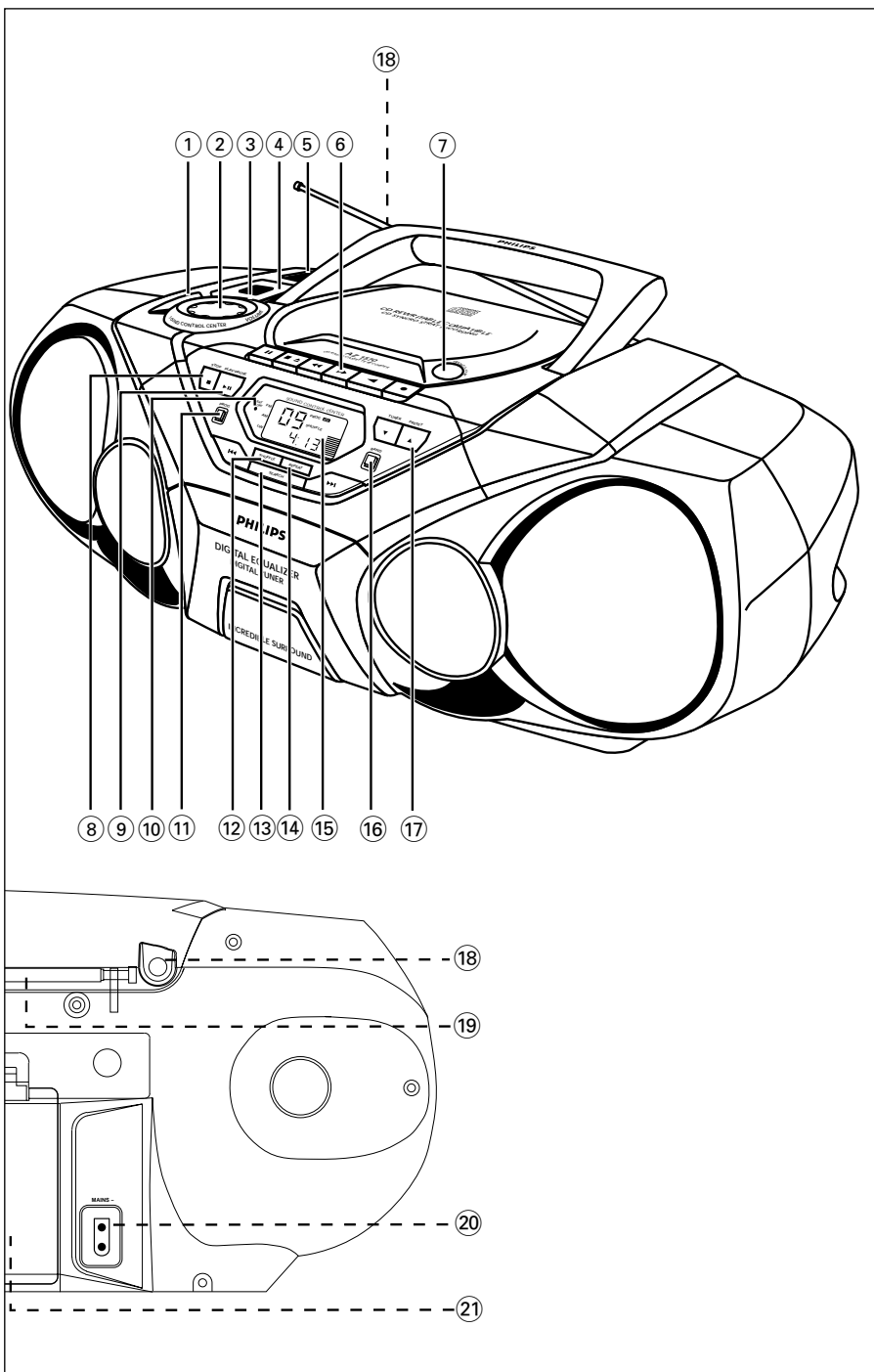

CAUTION

Use of controls or adjustments or performance of procedures other than herein may result in hazardous radiation exposure.

ATTENTION

L'utilisation des commandes ou réglages ou le non-respect des procédures ci-inclues peuvent se traduire par une exposition dangereuse à l'irradiation.

ATENCIÓN

El uso de mandos o ajustes o la ejecución de métodos que no sean los aquí descritos puede ocasionar peligro de exposición a radiación.

The set complies with the FCC-Rules, Part 15 and with 21 CFR 1040.10.

Operation is subject to the following two conditions:

- 1. This device may not cause harmful interference, and*
- 2. This device must accept any interference received, including interference that may cause undesired operation.*

L'appareil répond aux normes FCC, Part 15 et 21 CFR 1040.10.

Fonctionnement soumis aux deux conditions suivantes:

- 1. Cet appareil ne doit pas provoquer d'interférences nuisibles, et*
- 2. Cet appareil doit accepter toute interférence reçue, y compris les interférences susceptibles de provoquer un fonctionnement peu satisfaisant.*

El aparato cumple las normas FCC, Parte 15 y 21 CFR 1040.10.

Funcionamiento dependiente de dos condiciones siguientes:

- 1. Este aparato no puede provocar interferencia dañina, y*
- 2. Este aparato debe aceptar cualquier interferencia recibida, incluyendo las interferencias que pueden provocar un funcionamiento insuficiente.*

English

Safety instructions.....	2, 4, 6	CD Player	12-14
Limited warranty.....	7	Cassette recorder	14-15
Controls.....	8	Recording	16
Power supply.....	9	General information	11+16
Basic functions.....	10	Troubleshooting.....	17
Digital tuner.....	10-11		

English

Français

Conseils de sécurité	4, 18, 19	Lecteur de CD	25-27
Garantie limitée	20	Platine cassette	27-28
Commandes.....	21	Enregistrement.....	29
Alimentation.....	22	Informations generales.....	24+29
Fonctions de base	23	Dépannage	30
Syntoniseur numérique.....	23-24		

Français

Español

Instrucciones sobre seguridad	4, 31, 32	Sintonizador digital.....	36-37
Garantía limitada	33	Reproductor de CD.....	38-40
Controles	34	Grabadora de casetas.....	40-41
Suministro de energía.....	35	Grabación	42
Funciones básicas	36	Información general	36+42
		Problemas y soluciones	43

Español

CANADA



English: This digital apparatus does not exceed the Class B limits for noise emissions from digital apparatus as set out in the Radio Interference Regulations of the Canadian Department of Communications.

Français: Cet appareil numérique n'émet pas de bruits radioélectriques dépassant les limites applicables aux appareils numériques de Classe B prescrites dans le Règlement sur le Brouillage Radioélectrique édicté par le Ministère des Communications du Canada.

IMPORTANT SAFETY INSTRUCTIONS –

Read before operating equipment

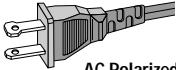
This product was designed and manufactured to meet strict quality and safety standards. There are, however, some installation and operation precautions which you should be particularly aware of.

- 1. Read these instructions** – All the safety and operating instructions should be read before the appliance is operated.
- 2. Keep these instructions** – The safety and operating instructions should be retained for future reference.
- 3. Heed all warnings** – All warnings on the appliance and in the operating instructions should be adhered to.
- 4. Follow all instructions** – All operating and use instructions should be followed.
- 5. Do not use this apparatus near water** – for example, near a bathtub, washbowl, kitchen sink, laundry tub, in a wet basement or near a swimming pool, etc.
- 6. Clean only with a damp cloth.** The appliance should be cleaned only as recommended by the manufacturer.
- 7. Install in accordance with the manufacturers instructions. Do not block any of the ventilation openings.** For example, the appliance should not be situated on a bed, sofa, rug, or similar surface or placed in a built-in installation, such as a bookcase or cabinet that may impede the flow of air through the ventilation openings.
- 8. Do not install near any heat sources** such as radiators, heat registers, stoves, or other apparatus (including amplifiers) that produce heat.
- 9. Do not defeat the safety purpose** of the polarized or grounding-type plug. A polarized plug has two blades with one wider than the other. A grounding type plug has two blades and a third grounding prong. The wide blade or the third prong are provided for your safety. When the provided plug does not fit into your outlet, consult an electrician for replacement of the obsolete outlet.
- 10. Protect the power cord** from being walked on or pinched particularly at plugs, convenience receptacles, and the point where they exit from the apparatus.
- 11. Only use attachments/accessories** specified by the manufacturer.
- 12.  Use only with a cart,** stand, tripod, bracket, or table specified by the manufacturer, or sold with the apparatus. When a cart is used, use caution when moving the cart/apparatus combination to avoid injury from tip-over.
- 13. Unplug this apparatus** during lightning storms or when unused for long periods of time.
- 14. Refer all servicing** to qualified service personnel. Servicing is required when the apparatus has been damaged in any way, such as power-supply cord or plug is damaged, liquid has been spilled or objects have fallen into the apparatus, the apparatus has been exposed to rain or moisture, does not operate normally, or has been dropped.

EL 4562-E004: 99/3

LIMITED WARRANTY

PORTABLE AUDIO

One Year Free Exchange

This product must be carried in for an exchange.

WHO IS COVERED?

You must have proof of purchase to exchange the product. A sales receipt or other document showing that you purchased the product is considered proof of purchase. Attach it to this owner's manual and keep both nearby.

WHAT IS COVERED?

Warranty coverage begins the day you buy your product. For one year thereafter, a defective or inoperative product will be replaced with a new, renewed or comparable product at no charge to you. A replacement product is covered only for the original warranty period. When the warranty on the original product expires, the warranty on the replacement product also expires.

WHAT IS EXCLUDED?

Your warranty does not cover:

- labor charges for installation or setup of the product, adjustment of customer controls on the product, and installation or repair of antenna systems outside of the product.
- product repair and/or part replacement because of misuse, accident, unauthorized repair or other cause not within the control of Philips Consumer Electronics Company.
- reception problems caused by signal conditions or cable or antenna systems outside the unit.
- a product that requires modification or adaptation to enable it to operate in any country other than the country for which it was designed, manufactured, approved and/or authorized, or repair of products damaged by these modifications.
- incidental or consequential damages resulting from the product. (Some states do not allow the exclusion of incidental or consequential damages, so the above exclusion may not apply to you. This includes, but is not limited to, prerecorded material, whether copyrighted or not copyrighted.)
- a product used for commercial or institutional purposes.

WHERE IS EXCHANGE AVAILABLE?

You may exchange the product in all countries where the product is officially distributed by Philips Consumer Electronics Company. In countries where Philips Consumer Electronics Company does not distribute the product, the local Philips service organization will attempt to provide a replacement product (although there may be a delay if the appropriate product is not readily available).

BEFORE REQUESTING EXCHANGE...

Please check your owner's manual before requesting an exchange. Adjustments of the controls discussed there may save you a trip.

EXCHANGING A PRODUCT IN U.S.A., PUERTO RICO OR U.S. VIRGIN ISLANDS...

Contact your dealer to arrange an exchange. Or, ship the product, insured and freight prepaid, and with proof of purchase enclosed, to the address listed below.

Small Product Service Center
Phillips Service Company
907 Snapps Ferry Road, Plant 2, Building 6
Greenville, TN 37743

(In U.S.A., Puerto Rico and U.S. Virgin Islands, all implied warranties, including implied warranties of merchantability and fitness for a particular purpose, are limited in duration to the duration of this express warranty. But, because some states do not allow limitations on how long an implied warranty may last, this limitation may not apply to you.)

EXCHANGING A PRODUCT IN CANADA...

Please contact Philips at:

1-800-661-6162 (French Speaking)
1-800-363-7278 (English Speaking)

(In Canada, this warranty is given in lieu of all other warranties. No other warranties are expressed or implied, including any implied warranties of merchantability or fitness for a particular purpose. Philips is not liable under any circumstances for any direct, indirect, special, incidental or consequential damages, howsoever incurred, even if notified of the possibility of such damages.)

TO GET OUT-OF-WARRANTY EXCHANGE...

In U.S.A., Puerto Rico or U.S. Virgin Islands, contact Philips Service Company at (800) 531-0039 to obtain the cost of out-of-warranty exchange. Then carefully pack the product and ship it to the Small Product Service Center (address listed above). In Canada, call the phone number listed above under "Exchanging a Product in Canada" to obtain the cost of out-of-warranty exchange.

REMEMBER...

Please record the model and serial numbers found on the product below. Also, please fill out and mail your warranty registration card promptly. It will be easier for us to notify you if necessary.

MODEL # _____

SERIAL # _____

This warranty gives you specific legal rights. You may have other rights which vary from state/province to state/province.

Philips Service Solutions Group, P.O. Box 2976, Longview, Texas 75606, (903) 242-4800

EL6095T002 / MACS433 / 1-97

CONTROLS

TOP AND FRONT PANELS

- ① **DIGITAL EQUALIZER** – selects volume or the various frequencies for adjustment: volume, bass, mid and high frequencies
- ② **VOLUME/SOUND CONTROL CENTER** – adjusts the volume level and digital equalizer settings
- ③ **DIGITAL DBB (Dynamic Bass Boost)** – enhances the bass
- ④ **INCREDIBLE SURROUND** – creates a super-enhanced stereo effect
- ⑤ **POWER slider** – selects the sound source for CD/ TUNER/ TAPE and also switches the set off
- ⑥ **CASSETTE RECORDER keys:**
RECORD ● – starts recording
PLAY ◀ – starts playback
SEARCH ◀◀, ▶▶ – fast winds/rewinds the tape
OPEN•STOP ▲ ■ – opens the cassette compartment
– stops the tape;
PAUSE || – interrupts recording or playback
- ⑦ **OPEN•CLOSE** – opens/ closes the CD door
- ⑧ **STOP ■** – stops CD playback or erase a CD program
- ⑨ **PLAY•PAUSE ▶||** – starts or interrupts CD playback
- ⑩ **BATT LOW** – indicates when battery power is running low

- ⑪ **PROG** – CD: programs tracks and reviews the program;
Tuner: programs preset tuner stations
- ⑫ **SHUFFLE** – plays CD tracks in random order
- ⑬ **SEARCH ◀◀, ▶▶**
Tuner: - (down, up) tunes to radio stations;
CD: - searches back and forward within a track;
- skips to the beginning of a current track/ previous/ subsequent track
- ⑭ **REPEAT** – repeats a track / CD program / entire CD
- ⑮ **Display** – shows the status of the set
- ⑯ **BAND** – selects waveband
- ⑰ **TUNER PRESET ▼, ▲** – selects a preset tuner station (down, up)

BACK PANEL

- ⑱ **🔌** – 3.5 mm headphone jack
- ⑲ **Telescopic antenna** – improves FM reception
- ⑳ **AC MAINS** – inlet for power cord
- ㉑ **Battery door**

Environmental information

All unnecessary packaging material has been omitted. We have done our utmost to make the packaging easy to separate into three mono-materials: cardboard (box), expandable polystyrene (buffer), polyethylene (bags, protective foam).

Your set consists of materials which can be recycled if disassembled by a specialized company. Please observe the local regulations regarding the disposal of packing materials, dead batteries and old equipment.

Whenever convenient, use the AC power supply if you want to conserve battery life. Make sure you remove the plug from the set and wall outlet before inserting batteries.

BATTERIES (OPTIONAL)

1. Open the battery compartment and insert six batteries, type **R-20, UM-1** or **D-cells**, (preferably alkaline) with the correct polarity as indicated by the "+" and "-" symbols inside the compartment.
2. Replace the compartment door, making sure the batteries are firmly and correctly in place. The set is now ready to operate.
 - If **BATT LOW** lights up, battery power is running low.
 - The **BATT LOW** indicator eventually goes out if the batteries are too weak.
 - *Incorrect use of batteries can cause electrolyte leakage and will corrode the compartment or cause the batteries to burst. Therefore:*
 - *Do not mix battery types, e.g. alkaline with carbon zinc. Only use batteries of the same type for the set.*
 - *When inserting new batteries, do not try to mix old batteries with the new ones.*
 - *Remove the batteries if the set is not to be used for a long time.*
 - ***Batteries contain chemical substances, so they should be disposed of properly.***

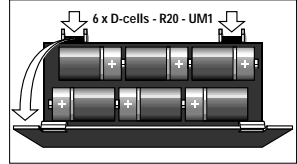

USING AC POWER

1. Check if the mains voltage **as shown on the type plate located on the bottom of the set**, corresponds to your local AC power supply. If it does not, consult your dealer or service center.
2. If your set is equipped with a voltage selector, adjust the selector so that it matches with the local power.
3. Connect the power cord to the wall outlet and the set is now ready for use.
4. To disconnect the set from the power completely, remove the plug from the wall outlet.

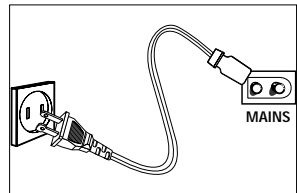

SWITCHING ON AND OFF

- Adjust the **POWER** slider to the desired sound source: **CD**, **TUNER** or **TAPE**.
- The set is switched off when the **POWER** slider is in the **TAPE/OFF** position and the keys on the tape deck are released.
- The volume, sound settings and tuner presets will be retained in the set's memory.



ADJUSTING VOLUME AND SOUND

1. Turn the **VOLUME/ SOUND CONTROL CENTER** control clockwise to increase or anti-clockwise to decrease volume on the set.
 - Display shows the volume level indication, **VOL** and a number from 0-32.
2. To adjust the bass, mid and high frequency levels, press **DIGITAL EQUALIZER** once or more until the desired option is displayed. While the option is shown, turn the **VOLUME/ SOUND CONTROL CENTER** control to increase or decrease (-5 to +5 steps maximum) the desired frequency.
 - **VOLUME** can also be adjusted in this way with a level range from 0-32.
3. Press **DIGITAL DBB** to switch dynamic bass boost on or off.
 - If on, the **DIGITAL DBB** light goes on.
4. Press **INCREDIBLE SURROUND** to switch the surround sound effect on or off.
 - If on, the **INCREDIBLE SURROUND** light goes on.

Note: The effect of **INCREDIBLE SURROUND** may vary with different types of music.

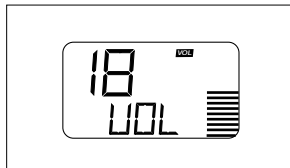
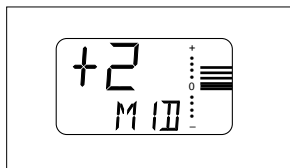
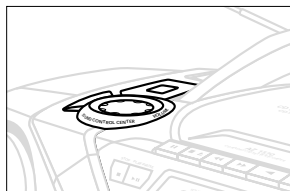

TUNING TO RADIO STATIONS

1. Select **TUNER** source.
 - **FM** is displayed briefly and then the radio station frequency is shown.
2. Press **BAND** once or more to select your waveband.
3. Press **SEARCH** **◀◀** or **▶▶** and release when the frequency in the display starts running.
 - The **TUNER** automatically tunes to a station of sufficient reception. Display shows *Srch* during automatic tuning.
 - If an FM station is received in stereo, **STEREO** is shown.
4. Repeat step 3 if necessary until you find the desired station.
 - To tune to a weak station, press **SEARCH** **◀◀** or **▶▶** briefly and repeatedly until you have found optimal reception.

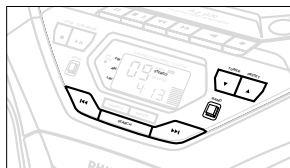

To improve radio reception:

- For **FM**, pull out the telescopic antenna. Incline and turn the antenna. Reduce its length if the signal is too strong (very close to a transmitter).
- For **AM**, the set is provided with a built-in antenna so the telescopic antenna is not needed. Direct the antenna by turning the whole set.

Programming tuner stations

You can store up to a total of 30 tuner stations in the memory.

1. Tune to your desired station (see Tuning to radio stations).
2. Press **PROG** to activate programming.
→ Display: **PROG** flashes.
3. Press **PRESET ▲** or **▼** once or more to allocate a number from 1 to 30 to this station.
4. Press **PROG** again to confirm the setting.
→ Display: **PROG** disappears, the preset number and the frequency of the preset station are shown.
5. Repeat the above four steps to store other stations.
 - You can overwrite a preset station by storing another frequency in its place.

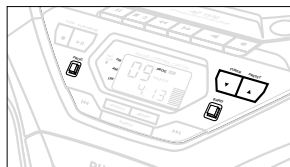
**Tuning to preset stations**

Press **TUNER PRESET ▼** or **▲** until the desired preset station is displayed.

General maintenance

- Do not expose the set, batteries, CDs or cassettes to humidity, rain, sand or excessive heat caused by heating equipment or direct sunlight.
- To clean the set, use a soft, slightly dampened chamois leather. Do not use any cleaning agents containing alcohol, ammonia, benzene or abrasives as these may harm the housing.

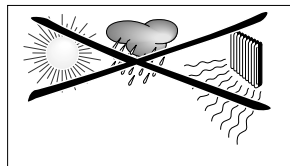
**Safety information**

- Place the set on a hard and flat surface so that the system does not tilt. Make sure there is adequate ventilation to prevent the system from overheating.
- The mechanical parts of the set contain self-lubricating bearings and must not be oiled or lubricated.



CD PLAYER

Playing a CD

1. Select **CD** source.
2. Press **OPEN•CLOSE** to open the CD door.
→ Display: CD OPEN when you open the CD door.
3. Insert a CD or CD-R(W) with the printed side facing up and press **OPEN•CLOSE** to close the CD door.
→ Display: CD 15C as the CD player scans the contents of a CD. The total number of tracks and playing time are then shown.
→ Display: CD 15C is shown if the CD R(W) is not finalized.
4. Press **PLAY•PAUSE ▶II** to start playback.
→ Display: Current track number and elapsed playing time of the track during CD playback.
5. To interrupt playback press **PLAY•PAUSE ▶II**. Press **PLAY•PAUSE ▶II** again to resume play.
→ The display freezes and the elapsed playing time flashes when playback is paused.
6. To stop CD playback, press **STOP ■**.

Note: CD play will also stop when:

- the CD door is opened;
- the CD has reached the end (unless you have selected **REPEAT ALL**);
- you select another source: **TAPE / TUNER**.

Selecting a different track

- Press **SEARCH ◀◀** or **▶▶** once or repeatedly until the desired track number appears in the display.
- If you have selected a track number shortly after loading a CD or in the **PAUSE** position, you will need to press **PLAY•PAUSE ▶II** to start playback.

Finding a passage within a track

1. Press and hold down on **SEARCH ◀◀** or **▶▶**.
– The CD is played at high speed and low volume.
2. When you recognize the passage you want, release **SEARCH ◀◀** or **▶▶**.
– Normal playback continues.

Note: During a CD program or if **SHUFFLE/ REPEAT** active, searching is only possible within a track.

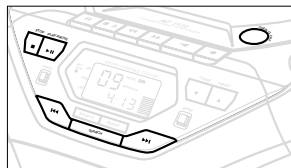

Different play modes: SHUFFLE and REPEAT

You can select and change the various play modes before or during playback. The play modes can also be combined with PROGRAM.

SHUFFLE - tracks of the entire CD/ program are played in random order

SHUFFLE and **REPEAT ALL** - to repeat the entire CD/ program continuously in random order

REPEAT ALL - to repeat the entire CD/ program

REPEAT and **SHUFFLE REPEAT** - plays the current (random) track continuously

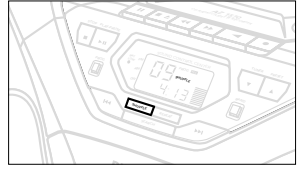

1. To select your play mode, press the **SHUFFLE** or **REPEAT** button before or during playback until the display shows the desired function.
2. Press **PLAY•PAUSE** ►|| to start playback if in the STOP position.
 - Playback starts immediately if you have selected a SHUFFLE mode.
3. To return to normal playback, press the respective **SHUFFLE** or **REPEAT** button until the various SHUFFLE / REPEAT modes are no longer displayed.
 - You can also press **STOP** ■ to cancel your play mode.

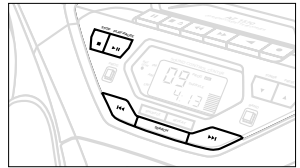

Programming track numbers

Program in the STOP position to select and store your CD tracks in the desired sequence. If you like, store any track more than once. Up to 20 tracks can be stored in the memory.

1. Press **SEARCH** ◀◀ or ▶▶ once or more to select your desired track number.
2. Press **PROG**.
 - Display: **PROG** and the selected track number. *PROG* appears briefly.
 - If you attempt to program without first selecting a track number, *SEL* is shown.
3. Repeat steps 1-2 to select and store all desired tracks.
 - *FULL* is displayed if you attempt to program more than 20 tracks.
4. To start playback of your CD program, press **PLAY•PAUSE** ►||.

Note: if you have selected the tracks during CD playback, first press **STOP** ■ then **PLAY•PAUSE** ►||.

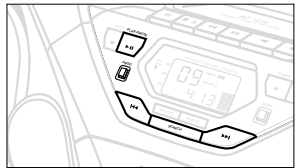

Reviewing the program

In the stop position or during playback, press and hold down **PROG** for a while until the display shows all your stored track numbers in sequence.

Erasing a program

You can erase the program by:

- pressing **STOP** ■ once in the STOP position;
- pressing **STOP** ■ twice during playback;
- The display shows $\overline{1} \overline{2} \overline{3} \overline{4} \overline{5}$ briefly and **PROG** disappears.

The program is also erased by:

- pressing the CD door open;
- selecting another source: TAPE/ TUNER.

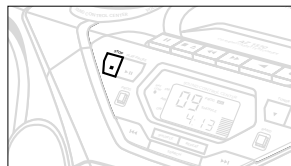

CASSETTE PLAYBACK

1. Select **TAPE** source.

→ The display shows **TAPE** throughout tape operation.

2. Press **OPEN•STOP** ▲■ to open the cassette door.

3. Insert a recorded cassette and close the cassette door.

4. Press **PLAY** ◀ to start playback.

5. To interrupt playback press **PAUSE** II. To resume, press this key again.

6. By pressing **SEARCH** ◀◀ or ▶▶ on the set fast winding of the tape is possible in both directions.

7. To stop the tape, press **OPEN•STOP** ▲■.

- The keys are automatically released at the end of the tape, except if **PAUSE** II has been activated.

Note: The sound source cannot be changed while playing a cassette.

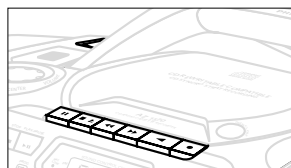

GENERAL INFORMATION ON RECORDING

- Recording is permissible insofar as copyright or other rights of third parties are not infringed.
- This deck is not suited for recording on CHROME (IEC II) or METAL (IEC IV) type cassettes. For recording, use only NORMAL type cassettes (IEC I) on which the tabs have not been broken.
- The best recording level is set automatically. Altering the VOLUME, INCREDIBLE SURROUND, DIGITAL EQUALIZER or DBB controls will not affect the recording in progress.
- At the very beginning and end of the tape, no recording will take place during the 7 seconds, when the leader tape passes the recorder heads.
- To protect a tape from accidental erasure, have the tape in front of you and break out the left tab.
Recording on this side is no longer possible. To record over this side again, cover the tabs with a piece of adhesive tape.

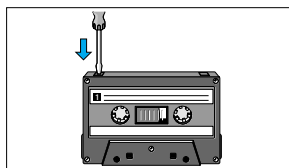

Synchro Start CD recording

1. Select **CD** source.
2. Insert a CD and if desired, program track numbers.
3. Press **OPEN•STOP** to open the cassette door.
4. Insert a suitable tape into the cassette deck and close the cassette door.
5. Press **RECORD** to start recording.
 - Playing of the CD program starts automatically from the beginning of the program. It is not necessary to start the CD player separately.

To select and record a particular passage within a track:

- Press and hold down on **SEARCH** or .
 - When you recognize the passage you want, release **SEARCH** or .
 - To interrupt CD playback press **PLAY•PAUSE** .
 - Recording will begin from this exact point in the track when you press **RECORD** .
6. For brief interruptions during recording, press **PAUSE** . To resume recording, press **PAUSE** again.
 7. To stop recording, press **OPEN•STOP** .

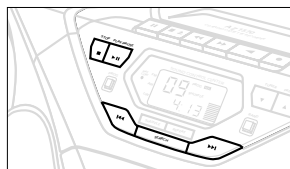

Recording from the tuner

1. Tune to the desired radio station (see Tuning to radio stations).
2. Press **OPEN•STOP** ▲■ to open the cassette door.
3. Insert a suitable tape into the cassette deck and close the cassette door.
4. Press **RECORD** ● to start recording.
5. For brief interruptions, press **PAUSE** II To resume recording, press **PAUSE** II again.
6. To stop recording, press **OPEN•STOP** ▲■.

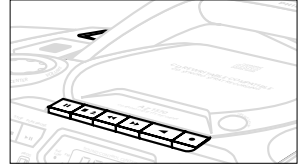

CD player and CD handling

- If the CD player cannot read CDs correctly, use a commonly available cleaning CD to clean the lens before taking the set to repair. Other cleaning methods may destroy the lens.
- The lens of the CD player should never be touched!
- Sudden changes in the surrounding temperature can cause condensation to cloud over on the lens of your CD player. Playing a CD is then not possible. Do not attempt to clean the lens but leave the set in a warm environment until the moisture evaporates.
- Always keep the CD compartment closed to avoid dust on the lens.
- To take a CD out of its box, press the center spindle while lifting the CD. Always pick up the CD by the edge and return the CD to its box after use to avoid scratching and dust.
- To clean the CD, wipe in a straight line from the center towards the edge using a soft, lint-free cloth. Do not use cleaning agents as they may damage the disc.
- *Never* write on a CD or attach any stickers to it.

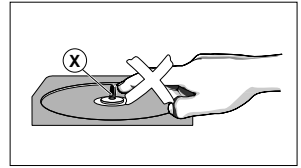

Tape deck maintenance

To ensure quality recording and playback of the tape deck, clean parts (A), (B) and (C) shown in the diagram below, after approx. 50 hours of operation, or on average once a month. Use a cotton bud slightly moistened with alcohol or a special head cleaning fluid to clean both decks.

1. Open the cassette holder by pressing **OPEN•STOP** ▲■.
2. Press **PLAY** ◀ and clean the rubber pressure rollers (C).
3. Press **PAUSE** II and clean the magnetic heads (A) and also the capstan (B).
4. After cleaning, press **OPEN•STOP** ▲■.

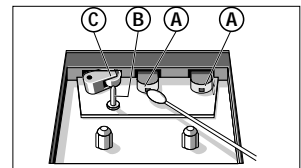

Note: *Cleaning of the heads can also be done by playing a cleaning cassette through once.*

TROUBLESHOOTING

If a fault occurs, first check the points listed below before taking the set for repair.
If you are unable to remedy a problem by following these hints, consult your dealer or service center.

WARNING: *Do not open the set as there is a risk of electric shock. Under no circumstances should you try to repair the set yourself, as this will invalidate the warranty.*

PROBLEM

– POSSIBLE CAUSE

- REMEDY

No sound/power

– VOLUME not adjusted

- Adjust the VOLUME

– Headphones connected

- Disconnect headphones

– Power cord not securely connected

- Connect AC power cord properly

Severe radio hum or noise

– Electrical interference: set too close to TV, VCR or computer

- Increase the distance

Poor radio reception

– Weak radio signal

- FM: Direct the FM telescopic aerial for optimum reception

CD indication

– CD badly scratched or dirty

- Replace/ clean CD, see Maintenance

– Laser lens steamed up

- Wait until lens has cleared

The CD skips tracks

– CD damaged or dirty

- Replace or clean CD
- SHUFFLE or PROGRAM is active
- Switch off SHUFFLE / PROGRAM

Poor cassette sound quality

– Dust and dirt on the heads, etc.

- Clean deck parts, see Maintenance
- Use of incompatible cassette types (METAL or CHROME)
- Only use NORMAL (IEC I) for recording

Recording does not work

– Cassette tab(s) may be broken

- Apply a piece of adhesive tape over the missing tab space.

CD-R indication

– CD-R(W) is blank or the disc is not finalized

- Use a finalized CD-R(W)

The type plate is located on the bottom of the set.