

MP3-CD Soundmachine



EXPANIUM

Let's make things better.



PHILIPS

Important notes for users in the U.K.

Mains plug

This apparatus is fitted with an approved moulded 13 Amp plug. To change a fuse in this type of plug proceed as follows:

- 1 Remove fuse cover and fuse.
- 2 Fix new fuse which should be a BS1362 5 Amp, A.S.T.A. or BSI approved type.
- 3 Refit the fuse cover.

If the fitted plug is not suitable for your socket outlets, it should be cut off and an appropriate plug fitted in its place. If the mains plug contains a fuse, this should have a value of 5 Amp. If a plug without a fuse is used, the fuse at the distribution board should not be greater than 5 Amp.

Note: The severed plug must be disposed to avoid a possible shock hazard should it be inserted into a 13 Amp socket elsewhere.

How to connect a plug

The wires in the mains lead are coloured with the following code: blue = neutral (N), brown = live (L).

- As these colours may not correspond with the colour markings identifying the terminals in your plug, proceed as follows:
 - Connect the blue wire to the terminal marked N or coloured black.
 - Connect the brown wire to the terminal marked L or coloured red.
 - Do not connect either wire to the earth terminal in the plug, marked E (or \perp) or coloured green (or green and yellow).

Before replacing the plug cover, make certain that the cord grip is clamped over the sheath of the lead - not simply over the two wires.

Copyright in the U.K.

Recording and playback of material may require consent. See Copyright Act 1956 and The Performer's Protection Acts 1958 to 1972.

Norge

Typeskilt finnes på apparatens underside.

Observer: Nettbryteren er sekundert innkopleet. Den innebygde nettdelen er derfor ikke frakopleet nettet så lenge apparatet er tilsluttet nettkontakten.

For å redusere faren for brann eller elektrisk støt; skal apparatet ikke utsettes for regn eller fuktighet.

Italia

DICHIARAZIONE DI CONFORMITA'

Si dichiara che l'apparecchio AZ 1138 Philips risponde alle prescrizioni dell'art. 2 comma 1 del D. M. 28 Agosto 1995 n. 548.

Fatto a Eindhoven

Philips Consumer Electronics
Philips, Glaslaan 2,
5616 JB Eindhoven, The Netherlands

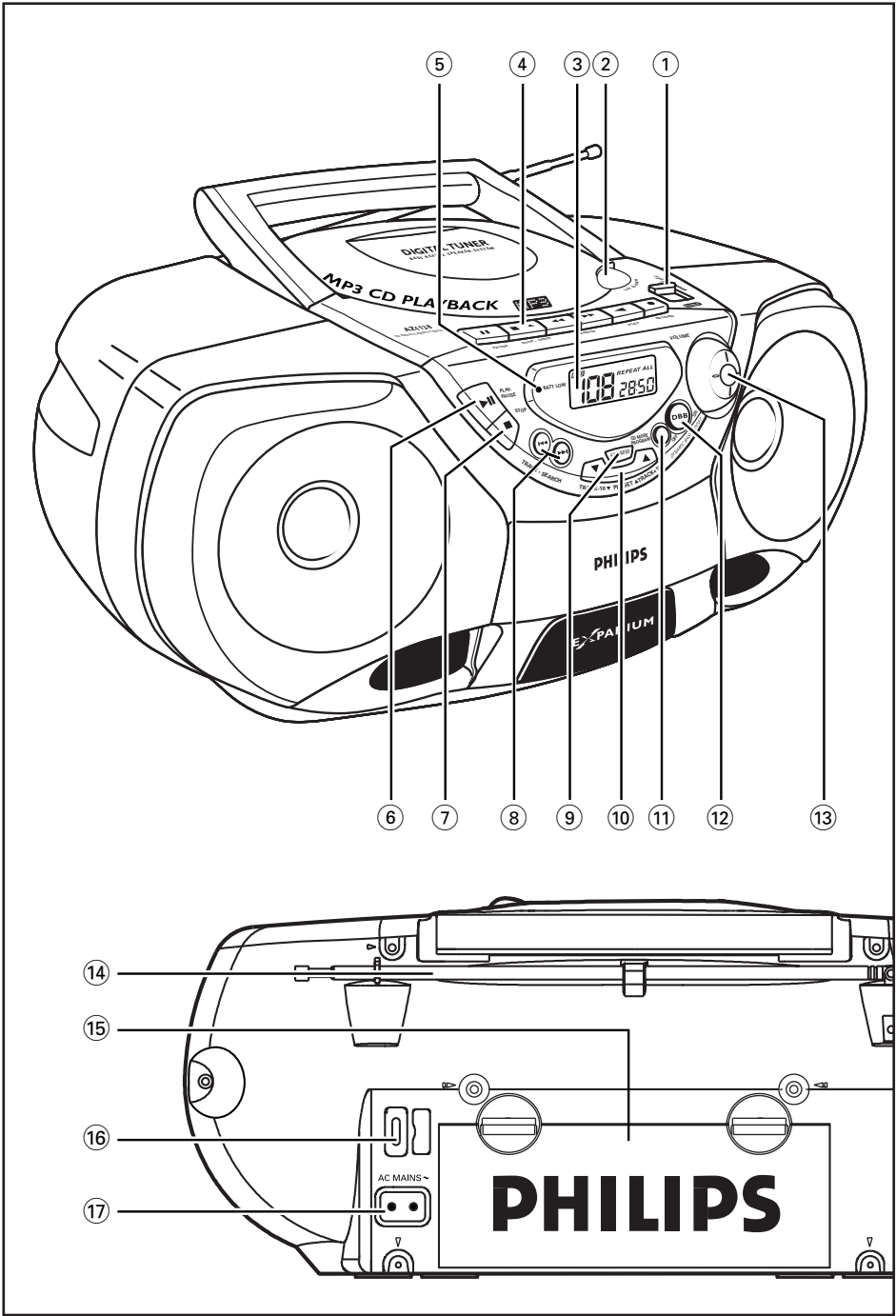

Caution

CAUTION: Use of controls or adjustments or performance of procedures other than herein may result in hazardous radiation exposure or other unsafe operation. This product complies with the radio interference requirements of the European Union.

ATTENTION: L'utilisation des commandes ou réglages ou le non-respect des procédures ci-inclues peuvent se traduire par une exposition dangereuse à l'irradiation. Ce matériel satisfait aux impératifs de brouillage radio de la Communauté Européenne.

ATENCIÓN: El uso de mandos o ajustes o la ejecución de métodos que no sean los aquí descritos puede ocasionar peligro de exposición a radiación. Este aparato satisface las normas relativas a la interferencia radioeléctrica de la Comunidad Europea.

ACHTUNG: Der Gebrauch von Bedienelemente oder Einstellungen bzw. Verfahrensausführungen die hier nicht ausdrücklich erwähnt worden sind, kann eine gefährliche Strahlendosierung oder andere unsichere Operationen zur Folge haben. Dieses Produkt entspricht den Funkentstörvorschriften der Europäischen Union.

LET OP: Het gebruik van de toetsen en regelingen of het toepassen van de aanwijzingen anders dan hier beschreven, kan leiden tot blootstelling aan gevaarlijke straling of tot onveilige werking. Dit apparaat voldoet aan de radio-ontstoringseisen van de Europese Unie.

ATTENZIONE: L'uso dei comandi o regolazioni o prestazioni delle procedure oltre a quelle descritte nel presente potrebbero causare esposizione a radiazioni pericolose o altre operazioni rischiose. Questo prodotto è conforme ai requisiti delle interferenze radio della Unione Europea.

AVISO: A utilização de comandos ou ajustes ou a execução de procedimentos de forma diferente daquela aqui indicada poderá resultar numa exposição perigosa a radiações ou noutra operação arriscada. Este produto obedece aos requisitos referentes a interferência de rádio estabelecidos pela União Europeia.

ADVARSEL: Anvendelse af andre betjeningsanordninger eller justeringer eller udførelse af andre procedurer end de heri angivne, kan medføre udsættelse for farlig stråling eller andre risici. Dette apparat overholder EU's krav vedrørende radiostøj.

WARNING: Om du använder knapparna på annat än här angivet sätt eller utför andra justeringar eller förfaranden än de här angivna kan du utsättas för skadlig strålning eller andra risker. Denna apparat uppfyller EU:s krav beträffande radiostörningar.

MUISTUTUS: Muiden kuin tässä kuvattujen säätimien tai säätöjen tai toimenpiteiden käyttö voi aiheuttaa vaarallisen altistuksen säteilylle tai muun turvallisuutta vaarantavan seurauksen. Tämä tuote on Euroopan unionin radiohäiriöitä koskevien vaatimusten mukainen.

ΠΡΟΣΟΧΗ: Οποιαδήποτε διαδικασία, χρήση ή ρύθμιση των ρυθμιστικών πλήκτρων και διακοπών εκτός των προβλεπόμενων στο παρόν εγχειρίδιο, μπορεί να έχει ως αποτέλεσμα την επιβλαβή έκθεση σε ακτινοβολία ή άλλη επικίνδυνη λειτουργία. Το προϊόν αυτό πληροί τις απαιτήσεις της Ευρωπαϊκής Ένωσης ως προς τις ραδιοπαρεμβολές.

English

English ————— 6

Svenska ————— 86

Français

Français ————— 16

Suomi ————— 96

Español

Español ————— 26

Ελληνικά ————— 106

Deutsch

Deutsch ————— 36

Nederlands

Nederlands ————— 46

Italiano

Italiano ————— 56

Português

Português ————— 66

Dansk

Dansk ————— 76

Svenska

Suomi

Ελληνικά

Controls

Top and Front Panels

- 1 POWER slider** – selects sound source for MP3-CD, CD, RADIO, TAPE/OFF, and the power on/ off switch
- 2 LIFT TO OPEN** – opens/ closes the CD door
- 3 Display** – shows the status of the set
- 4 Cassette recorder keys:**
PAUSE II – pauses recording or playback
STOP•OPEN ■▲ – stops the tape; opens the cassette door
SEARCH ◀◀ or ▶▶ – fast rewinds/ winds the tape
PLAY ◀ – starts playback
RECORD ● – starts recording
- 5 BATT LOW** – indicator lights up if battery power is running low
- 6 PLAY•PAUSE ▶▶ II** – starts or pauses MP3-CD/ CD playback
- 7 STOP ■** – stops MP3-CD/ CD playback; erases a MP3-CD/ CD programme
- 8 TRACK•SEARCH ◀◀ , ▶▶**
MP3-CD: skips or searches a passage/ track backwards or forward
RADIO: tunes to a radio station (up, down)
- 9 FM•MW** – selects FM/ MW waveband

- 10 TRACK +/-10 PRESET ▲, ▼**
MP3-CD: fast skips to the next/ previous 10 MP3-CD/ CD tracks (if available)
RADIO: selects a preset station (up, down)
- 11 CD MODE•PROGRAM**
MP3-CD: programmes and reviews programmed track numbers;
– plays tracks /discs/ programme in random order;
– repeats a track/disc/ programme
RADIO: programmes radio preset stations
- 12 DBB OFF/ON (Dynamic Bass Boost)** – enhances bass response
- 13 VOLUME** – adjusts volume level

Back Panel

- 14 Telescopic aerial** – to improve FM reception
- 15 Battery door** – open to insert 6 x 1.5V R14/UM2/ C-cell batteries
- 16 Voltage selector** – (not all versions) to match local mains before connecting the mains cord by adjusting the selector
- 17 AC MAINS** – inlet for mains cord

Environmental information

All unnecessary packaging material has been omitted. The packaging can be easily separated into three materials: cardboard, polystyrene and plastic.

Your set consists of materials which can be recycled if disassembled by a specialized company. Please observe the local regulations regarding the disposal of packing materials, exhausted batteries and old equipment.

Mains Supply

Whenever convenient, use the mains supply if you want to conserve battery life. Make sure you remove the plug from the set and wall outlet before inserting batteries.

Batteries (not included)

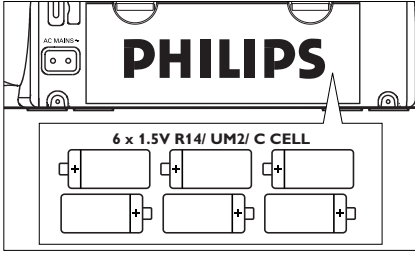

- 1 Open the battery compartment and insert six batteries, type **R-14**, **UM-2** or **C-cells**, (preferably alkaline) with the correct polarity as indicated by the "+" and "-" symbols inside the compartment.
- 2 Close the compartment door; and make sure the batteries are firmly and correctly in place. The set is now ready to operate.
→ If **BATT LOW** lights up, battery power is running low. The **BATT LOW** indicator eventually goes out if the batteries are too weak.

Batteries contain chemical substances, so they should be disposed of properly.

Incorrect use of batteries can cause electrolyte leakage and will corrode the compartment or cause the batteries to burst. Therefore:

- Do not mix battery types: e.g. alkaline with carbon zinc. Only use batteries of the same type for the set.

- When inserting new batteries, do not try to mix old batteries with the new ones.
- Remove the batteries if the set is not to be used for a long time.

Using AC Mains

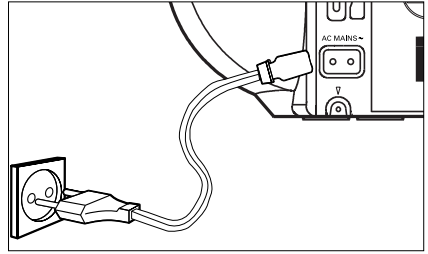

- 1 Check if the mains voltage, **as shown on the type plate located on the bottom of the set**, corresponds to your local mains supply. If it does not, consult your dealer or service centre.
 - 2 Connect the mains cord to the AC MAINS inlet and the wall outlet. The mains supply is now connected and ready for use.
 - 3 To switch off completely, unplug the mains cord from the wall outlet.
- Unplug the mains cord from the wall outlet to protect your set during heavy thunderstorms.

The type plate is located on the bottom of the set.

Switching power on/off: Save energy

Whether you are using mains or battery supply, to avoid unnecessary energy consumption always adjust the **POWER slider** to **TAPE/OFF** and check if the cassette keys are released.

General Operation

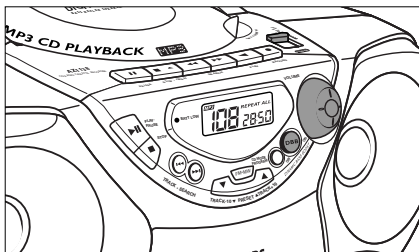

- 1 To select your sound source adjust the **POWER slider** to **CD, RADIO** or **TAPE/OFF**.
- 2 Adjust the sound with the **VOLUME** and **DBB OFF/ON** (Dynamic Bass Boost) controls.
- 3 To switch off the set, adjust the **POWER slider** to **TAPE/OFF** position and check the cassette keys are released.

Note: When the set is switched off the tuner presets will be retained in the set's memory.

Radio Reception

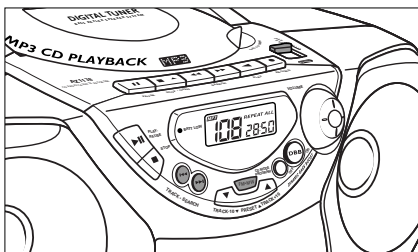

- 1 Adjust the **POWER slider** to **RADIO**.
 → Display: shows $\xi \omega$ briefly.
 The radio frequency is then shown.
- 2 Press **FM•MW** once or more to select the desired waveband.
 → Display: shows your waveband
- 3 Press and hold down **TRACK•SEARCH** \lll or \ggg briefly to tune to a radio station. Release when the frequency in the display starts to change.
 → The radio automatically tunes to a radio station of sufficient reception. Display shows $\xi \omega \xi \omega$ during automatic tuning.
- To tune to a weak station, press **TRACK•SEARCH** \lll or \ggg briefly and repeatedly until you have found optimal reception.

To improve reception

– For **FM**, pull out the telescopic aerial. Incline and turn the aerial.

Reduce its length if the signal is too strong (very close to a transmitter).

– For **MW** the set is provided with a built-in aerial so the telescopic aerial is not needed. Direct the aerial by turning the whole set.

- 4 To switch off the radio, adjust the **POWER slider** to **TAPE/OFF** position and check the cassette keys are released.

Programming Radio Stations

You can store up to a total of 30 radio stations in the memory.

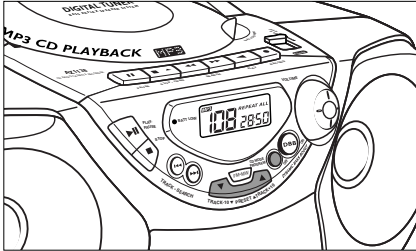

- 1 Tune to your desired station (see Radio Reception).
 - 2 Press **CD MODE•PROGRAM** to activate programming.
→ Display: **PROGRAM** flashes.
 - 3 Press **PRESET ▲** or **▼** once or more to allocate a number from 1 to 30 to this station.
 - 4 Press **CD MODE•PROGRAM** again to confirm the setting.
→ Display: **PROGRAM** disappears, the preset number and the frequency of the preset station are shown.
 - 5 Repeat the above four steps to store other stations.
- You can erase a preset station by storing another frequency in its place.

Tuning to preset stations

Press **PRESET ▲** or **▼** until the desired preset station is shown.

General Information on the MP3-CD/ CD Player

Supported formats

- Disc format: ISO 9960, Joliet, finalised multisession
- MP3 music files

- MP3 bit rate (data rate): 32-320 kbps and variable bit rate
- Total number of music files maximum: 999
- Some encoder software offer an option to protect music files, i.e. the files can only be played on the computer which created them. If you burn such files on a CD-ROM, you cannot play them on this unit. Make sure to deactivate the protection option in the encoder software before creating the music files. In this case you are responsible for adherence to all local or international copyrights.

MP3-CD

- Make sure the file names of the MP3 files end with .mp3

IMPORTANT!

Do not attempt to combine CD audio and MP3 tracks within a CD-R(W) or CD-ROM, as the set will only be able to playback your CD audio tracks from mixed CD formats.

This set does not play/ support the following:

- UDF disc format.
- Non-finalised discs.
- Recordings created on e.g. DirectCD, Packet Writing and Package Writing.
- Playlist files e.g. m3u, pls of WMA, AAC, Winamp, Sonic, RealJukebox, MS Mediaplayer 7.0, MusicMatch.

Display indication for MP3-CD/ CD functions

- **CD OPEN**: CD door open
- **CD 150**: when reading CD contents
- **CD**: icon throughout CD operation
- **MP3**: icon throughout MP3-CD operation
- **In CD stop mode**: total track number and total playback time
- **In MP3-CD stop mode**: total track number

MP3-CD/ CD-Player

- **During playback:** elapsed playback time of current track and current track number
- **Pause:** elapsed playback time freezes and flashes
- **SHUFFLE/ REPEAT** modes: when the respective mode is activated
- **PROGRAM:** when MP3 CD/ CD programme active; **PRPG** also appears briefly when you store a track
- **no SEL:** programme activated but no tracks selected
- **FULL:** programme memory full
- **no PRPG:** programme cancelled
- **CD Err, no disc or F d 15C:** error in CD operation/ no disc/ or a CD-R(W) is blank or the disc is not finalised (see Troubleshooting)

MP3-CD/ CD Playback

This unit can play:

- all pre-recorded audio CDs
- all finalised audio CDR(W)s
- MP3-CDs (CD-ROMs with MP3 files)

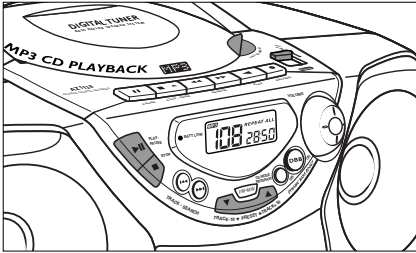

- 1 Adjust the **POWER slider** to **CD**.
→ Display: shows **CD** briefly.
- 2 To open the CD door, lift the CD door at the edge marked **LIFT TO OPEN**.
- 3 Insert a disc with the printed side facing up and press the CD door gently close.
- 4 Press **PLAY•PAUSE ►II** on the set to start playback.

- 5 To pause playback press **PLAY•PAUSE ►II**. To resume, press **PLAY•PAUSE ►II** again.
→ The elapsed playback time freezes and flashes.
- 6 To stop playback, press **STOP ■**.
- 7 To switch off the set, adjust the **POWER slider** to **TAPE/OFF** position and check the cassette keys are released.

Note: playback will also stop when:

- you open the CD compartment;
- you select **RADIO** or **TAPE** sound source;
- the disc has reached to the end.

Selecting a different track

During playback you can use the **TRACK•SEARCH ◀◀, ▶▶** or **TRACK +/-10 PRESET ▲, ▼** to select a particular track.

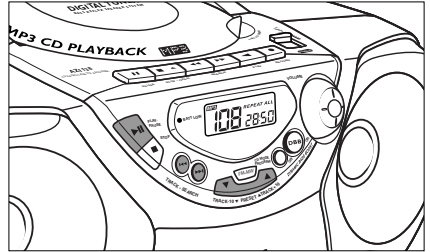

- If you have selected a track number in the stop or pause position, press **PLAY•PAUSE ►II** to start playback.
- Press **TRACK•SEARCH ▶▶** once briefly for the next track, or press repeatedly until the desired track number appears in the display.

- Press **TRACK-SEARCH** ⏮ once briefly to return to the beginning of a current track.
- Press **TRACK-SEARCH** ⏮ more than once briefly for a previous track.
- Press **TRACK +/-10 PRESET** ▲, ▼ once or more to fast skip to the next/previous 10 tracks.

Finding a passage within a track

- 1 During playback, press and hold down **TRACK-SEARCH** ⏮ or ⏭.
→ The disc is played at high speed and low volume.
- 2 When you reach the passage you want release the **TRACK-SEARCH** ⏮ or ⏭ button.
→ Normal playback resumes.

Note: During playback of a CD, MP3-CD, programme or when SHUFFLE/REPEAT is active, searching is only possible within a track.

Different Play Modes

CD MODE•PROGRAM allows you to select various play modes. The modes can be selected or changed during playback of an entire disc or programme in the following sequence:

SHUFFLE – all tracks are played in random order

SHUFFLE REPEAT ALL – repeats the entire disc in random order

REPEAT – plays the current track continuously

REPEAT ALL – plays the entire disc continuously

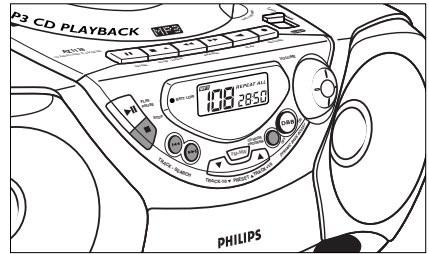

- 1 During playback, select your play mode by pressing **CD MODE•PROGRAM** once or more until the desired play mode is shown.
→ Display: your selected mode flashes 2 seconds before playback
- You can use **TRACK-SEARCH** ⏮, ⏭ or **TRACK +/-10 PRESET** ▲ or ▼ to skip tracks during the **SHUFFLE/ REPEAT** modes.
- The **SHUFFLE/ REPEAT** play options can be combined and used with a programme: e.g. **SHUFFLE/ REPEAT ALL** repeats the entire disc programme in random order.
- 2 To return to normal playback press **CD MODE•PROGRAM** until the **SHUFFLE/ REPEAT** modes are no longer shown.
- You can also press **STOP** ■ to quit the play mode.

Programming track numbers

You may store up to 20 tracks in the desired sequence. If you like, store any track more than once.

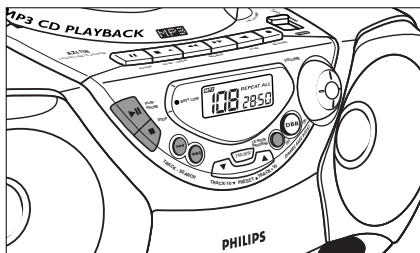

- 1 In the STOP mode, press **TRACK-SEARCH** **◀▶** or **TRACK +/-10 PRESET** **▲** or **▼** for your desired track.
- 2 When your chosen track number appears, press **CD MODE-PROGRAM** once to store the track.
 - The display shows **PROGRAM** and '1 0 8' briefly followed by your selected track number.
 - If you attempt to programme without first selecting a track number, '1 0 8 5 E L' is shown.
- 3 Repeat steps 1 to 2 to select and store all desired tracks in this way.
 - **F U L L** is displayed if you attempt to programme more than 20 tracks.
- 4 To play your programme, press **PLAY-PAUSE** **▶||**.

Reviewing your programme

- In the STOP mode, press and hold down **CD MODE-PROGRAM** for more than one second.
 - The display shows all your stored track numbers in sequence.

Erasing a programme

You can erase the contents of the memory by any one of the following:

- opening the CD door;
- selecting **RADIO** or **TAPE** source;
- pressing **STOP** **■** (twice during playback or in the stop position.)

→ Display: shows '1 0 8' briefly when the programme is cancelled.

Cassette playback

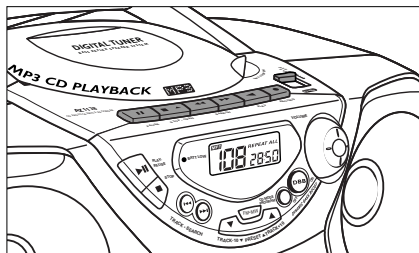

- 1 Adjust the **POWER slider** to **TAPE/OFF**.
- 2 Press **STOP-OPEN** **■▲** to open the cassette door and insert a recorded cassette.
- 3 Close the cassette door.
- 4 Press **PLAY** **◀** to start playback.
 - Display: shows **TAPE** throughout tape operation.
- 5 To pause playback press **PAUSE** **||**. To resume, press the key again.
- 6 By pressing **◀◀** or **▶▶**, fast winding of the tape is possible in both directions. To stop fast winding, press **STOP-OPEN** **■▲**.
- 7 To stop the tape, press **STOP-OPEN** **■▲**.
 - The keys are automatically released at the end of the tape, the **TAPE** indication goes out and the set is switched off, except if **PAUSE** **||** has been activated.

General information on Recording

- Recording is permissible insofar as copyright or other rights of third parties are not infringed.
- This deck is not suited for recording on CHROME (IEC II) or METAL (IEC IV) type cassettes. For recording, use only NORMAL type cassettes (IEC type I) on which the tabs have not been broken.
- At the very beginning and end of the tape, no recording will take place during the 7 seconds when the leader tape passes the recorder heads.
- To protect a tape from accidental erasure, have the tape in front of you and break out the left tab. Recording on this side is no longer possible. To record over this side again, cover the tabs with a piece of adhesive tape.

Synchro Start MP3-CD/ CD Recording

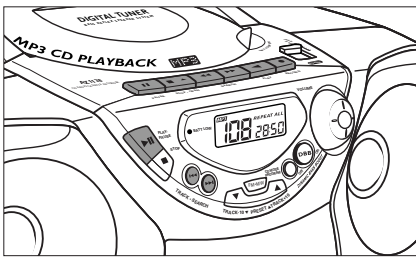

- 1 Select **CD** source.
- 2 Insert a disc and if desired, programme track numbers.
- 3 Press **STOP•OPEN** to open the cassette door. Insert a blank tape.

- 4 Close the cassette door.
- 5 Press **RECORD** to start recording.
- Playing of the disc programme starts automatically from the beginning of the programme. *It is not necessary to start the CD player separately.*
- 6 For brief interruptions press **PAUSE II**. To resume recording, press **PAUSE II** again.
- 7 To stop recording, press **STOP•OPEN** .

Selecting and recording a particular passage

- During playback, press and hold down **TRACK•SEARCH** or to find your passage.
- Press **PLAY•PAUSE** to put the CD player on pause at the selected passage.
 - Recording will begin from this exact point in the track when you press **RECORD** .

Recording from the Radio

- 1 Select **RADIO** source and your waveband.
- 2 Tune to the desired radio station (see **Radio reception**).
- 3 Press **STOP•OPEN** to open the cassette door. Insert a blank tape.
- 4 Close the cassette door.
- 5 Press **RECORD** to start recording.
- 6 For brief interruptions, press **PAUSE II**. To resume recording, press **PAUSE II** again.
- 7 To stop recording, press **STOP•OPEN** .

Precautions & General Maintenance

- Place the set on a hard and flat surface so that the system does not tilt.
- Do not expose the set, batteries, CDs or cassettes to humidity, rain, sand or excessive heat caused by heating equipment or direct sunlight.
- Do not cover the set. Adequate ventilation with a minimum gap of 6 inches between the ventilation holes and surrounding surfaces is necessary to prevent heat build-up.
- The mechanical parts of the set contain self-lubricating bearings and must not be oiled or lubricated.
- To clean the set, use a soft, dry chamois leather. Do not use any cleaning agents containing alcohol, ammonia, benzene or abrasives as these may harm the housing.

Tape deck maintenance

To ensure quality recording and playback of the tape deck, clean parts (A), (B) and (C) shown in the diagram below, after approx. 50 hours of operation, or on average once a month. Use a cotton bud slightly moistened with alcohol or a special head cleaning fluid to clean the deck.

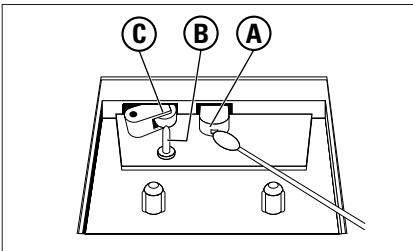

- 1 Open the cassette door by pressing **STOP•OPEN** ■▲.
 - 2 Press **PLAY** ◀ and clean the rubber pressure roller (C).
 - 3 Press **PAUSE** II and clean the magnetic heads (A), and also the capstan (B).
 - 4 After cleaning, press **STOP•OPEN** ■▲.
- Cleaning of the heads can also be done by playing a cleaning cassette through once.
- ### CD player and disc handling
- The lens of the CD player should never be touched!
 - Sudden changes in the surrounding temperature can cause condensation to form and the lens of your CD player to cloud over. Playing a disc is then not possible. Do not attempt to clean the lens but leave the set in a warm environment until the moisture evaporates.
 - Always close the CD door to keep the CD compartment dust-free. To clean, dust the compartment with a soft dry cloth.
 - To take a disc out of its box, press the centre spindle while lifting the disc. Always pick up the disc by the edge and replace the disc back in its box after use to avoid scratching and dust.
 - To clean the disc, wipe in a straight line from the centre towards the edge using a soft, lint-free cloth. Do not use cleaning agents as they may damage the disc.
 - Never write on a disc or attach any stickers to it.

If a fault occurs, first check the points listed below before taking the set for repair. Do not open the set as there is a risk of electric shock. If you are unable to remedy a problem by following these hints, consult your dealer or service centre.

WARNING: Under no circumstances should you try to repair the set yourself, as this will invalidate the guarantee.

Problem	Solution
No sound/ power	<ul style="list-style-type: none"> – Volume not adjusted. Adjust the VOLUME. – Mains cord not securely connected. Connect AC mains cord properly. – Batteries exhausted /incorrectly inserted. Insert (fresh) batteries correctly.
Display does not function properly/ No reaction to operation of any of the controls	<ul style="list-style-type: none"> – Electrostatic discharge. Switch off and unplug the set. Reconnect after a few seconds.
<i>no disc, Cd Err</i> or <i>no disc</i> indication/ MP3CD/ CD playback does not work	<ul style="list-style-type: none"> – No disc inserted. Insert a disc. – Disc badly scratched/ dirty. Replace/ clean disc (see maintenance). – CD-R(W) is blank or the disc is not finalised. Use a finalised CD-R(W). – Laser lens steamed up. Wait until lens has recovered to room temperature. – Incompatible format used for MP3. Check if your disc format is ISO 9960, Joliet, finalised multisession.
The disc skips tracks	<ul style="list-style-type: none"> – Disc damaged or dirty. Replace or clean CD. – SHUFFLE or a programme is active. Quit SHUFFLE/ programme mode.
Sound skips during MP3 playback	<ul style="list-style-type: none"> – MP3file made at compression level exceeding 320 kbps. Use a lower compression level to record CD tracks into MP3 format.
Cannot find desired MP3 title	<ul style="list-style-type: none"> – Wrong file extension/ used. Change file extension to .MP3
Poor cassette sound quality	<ul style="list-style-type: none"> – Dust and dirt on the heads, etc. Clean deck parts, see maintenance. – Use of incompatible cassette types (METAL or CHROME). Only use NORMAL (IEC I) for recording.
Recording does not work	<ul style="list-style-type: none"> – Cassette tab(s) may be broken. Apply a piece of adhesive tape over the missing tab space.