

CD Radio Cassette Recorder

AZ1020

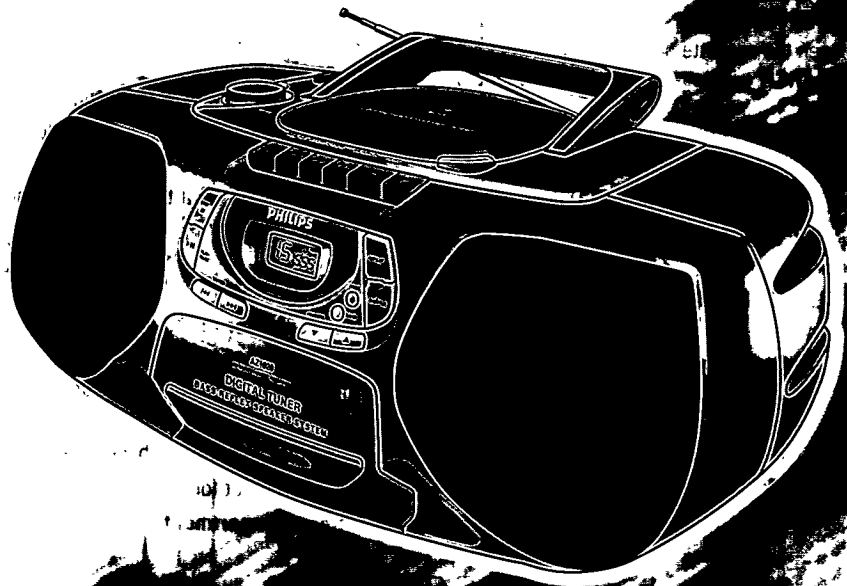

Let's make things better.



PHILIPS

Important notes for users in the U.K.

Mains plug

This apparatus is fitted with an approved moulded 13 Amp plug. To change a fuse in this type of plug proceed as follows:

- Remove fuse cover and fuse.
- Fix new fuse which should be a BS1362 5 Amp, A.S.T.A. or BSI approved type.
- Refit the fuse cover.

If the fitted plug is not suitable for your socket outlets, it should be cut off and an appropriate plug fitted in its place.

If the mains plug contains a fuse, this should have a value of 5 Amp. If a plug without a fuse is used, the fuse at the distribution board should not be greater than 5 Amp.

Note: The severed plug must be disposed to avoid a possible shock hazard should it be inserted into a 13 Amp socket elsewhere.

How to connect a plug

The wires in the mains lead are coloured with the following code: blue = neutral (N), brown = live (L). As these colours may not correspond with the colour markings identifying the terminals in your plug, proceed as follows:

- Connect the blue wire to the terminal marked N or coloured black.
- Connect the brown wire to the terminal marked L or coloured red.
- Do not connect either wire to the earth terminal in the plug, marked E (or \oplus) or coloured green (or green and yellow).

Before replacing the plug cover, make certain that the cord grip is clamped over the sheath of the lead - not simply over the two wires. Copyright in the U.K.: Recording and playback of material may require consent. See Copyright Act 1956 and The Performer's Protection Acts 1958 to 1972.

(N) Norge

Advarsel: For a redusere faren for brann eller elektrisk støt, skal apparatet ikke utsettes for regn eller fuktighet. Typeskilt finnes på apparatens underside.

Observer: Nettbryteren er sekundært innkopleet. Den innebygde nettdelen er derfor ikke frakopleet nettet så lenge apparatet er tilsluttet nettkontakten.

(I) Italia

DICHIARAZIONE DI CONFORMITA'

Si dichiara che l'apparecchio AZ 1020 Philips risponde alle prescrizioni dell'art. 2 comma 1 del D. M. 28 Agosto 1995 n. 548.

Fatto a Eindhoven, il 11/30/1998

Philips Sound & Vision
Philips, Glaslaan 2, SFF 10
5616 JB Eindhoven, The Netherlands

English 4

English

Français 13

Français

Español 22

Español

Deutsch 31

Deutsch

Nederlands 40

Nederlands

Italiano 49

Italiano

Português 58

Português

Dansk 67

Dansk

Svenska 76

Svenska

Suomi 85

Suomi

Ελληνικά 94

Ελληνικά

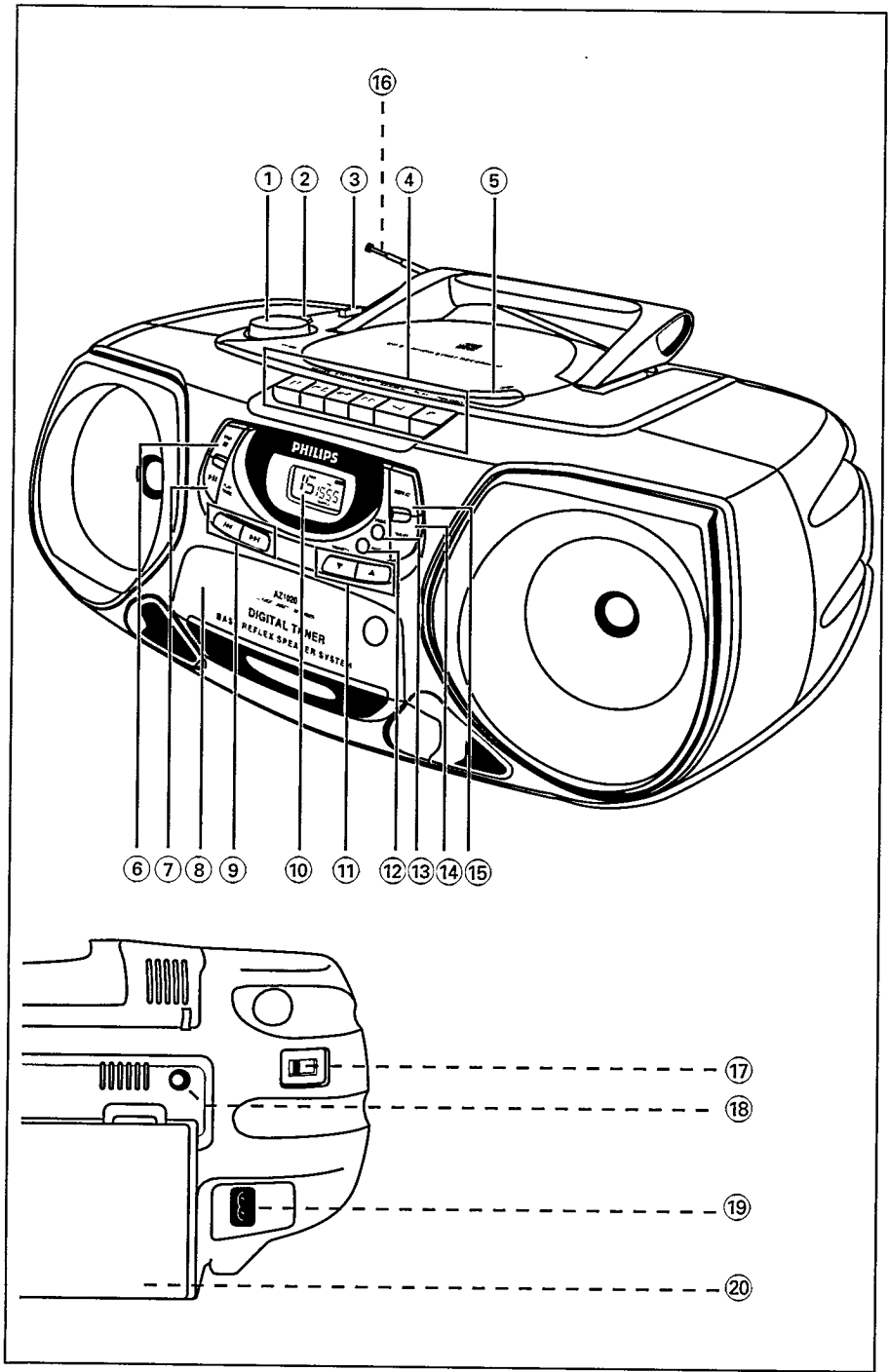

CONTROLS

English

TOP, FRONT AND SIDE PANEL

- ① **VOLUME** - to adjust volume level
- ② **DBB Dynamic Bass Boost** - enhances bass sound
- ③ **CD TUNER TAPE/OFF** - to select the sound source; to switch the set on / off
- ④ **CASSETTE RECORDER keys:**
 - PAUSE II** - to interrupt recording or playback
 - STOP•OPEN ■▲** - to stop the tape and to open the cassette holder
 - SEARCH ◀◀ , ▶▶** - to fast wind/rewind the tape
 - PLAY ◀** - to start playback
 - RECORD ●** - to start recording
- ⑤ **OPEN** - to open/ close the CD door
- ⑥ **STOP ■** - to stop playback or erase a programme
- ⑦ **PLAY•PAUSE ▶II** - to start or interrupt CD play
- ⑧ **Cassette compartment**
- ⑨ **SEARCH ◀◀ or ▶▶** -
 - CD:** to skip or search backwards and forwards within a track;
 - TUNER:** to tune to radio stations
- ⑩ **Display** - to show the status of the tuner / CD functions
- ⑪ **PRESET** - ▼,▲ (down, up) to select a preset tuner station
- ⑫ **BAND**
 - to select FM, MW or LW wave band;
 - to select 9/10 KHz tuning step from MW band (*not all versions*)
- ⑬ **PROG** -
 - CD:** to programme tracks and to review the programme
 - TUNER:** to programme preset tuner stations
- ⑭ **SHUFFLE** - to play CD tracks in random order
- ⑮ **REPEAT** - to repeat a track/CD programme/ entire CD

BACK PANEL

- ⑯ **Telescopic aerial** - to improve FM reception
- ⑰ **Voltage selector** (*not all versions*) - to select 120/230 V
- ⑱ **🎧** - 3.5 mm stereo headphone socket
- ⑲ **MAINS** - socket for mains lead
- ⑳ **Battery compartment**

IMPORTANT NOTE FOR USERS IN THE U.K.: SEE PAGE 2

Environmental information

All unnecessary packaging material has been omitted. We have done our utmost to make the packaging easily separable into three mono materials: cardboard, polystyrene and plastic

Your set consists of materials which can be recycled if disassembled by a specialized company. Please observe the local regulations regarding the disposal of packaging materials, exhausted batteries and old equipment.

BATTERIES

For the set (optional)

- Open the battery compartment and insert six batteries, type **R20, UM1** or **D-cells** (preferably alkaline) with the correct polarity as indicated by the (+) and (-) symbols inside the compartment.

Incorrect use of batteries can cause electrolyte leakage and will corrode the compartment or cause the batteries to burst.

Therefore:

- Do not mix battery types, e.g. alkaline with carbon zinc. Only use batteries of the same type for the set.
- When inserting new batteries, do not try to mix old batteries with the new ones.
- **Important!** Remove the batteries if the set is not to be used for a long time.

Batteries contain chemical substances, so they should be disposed of properly

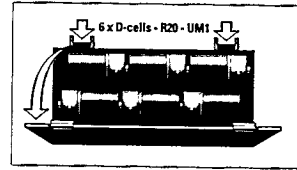

USING THE AC MAINS

1. Check if the mains voltage as shown on **the type plate on the base of the set**, corresponds to your local mains voltage. If it does not, consult your dealer or service organisation.
 - If your set is equipped with a voltage selector (A), adjust the selector to correspond with your local mains voltage.
2. Connect the mains lead (packed inside the battery compartment), to the MAINS socket and the wall socket. The mains supply is now connected and ready for use.
3. To disconnect the set from the mains completely, remove the plug from the wall socket.

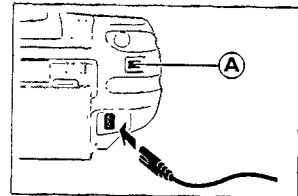

GENERAL OPERATION

1. To select sound source adjust the CD TUNER TAPE/OFF slider
2. Adjust the sound with the VOLUME and DBB (Dynamic Bass Boost) controls
3. To switch off the set, adjust the slider to TAPE/OFF position and check that the cassette keys are released.

Note:

When the set is switched off the tuner presets will be retained in the set's memory.

DIGITAL TUNER

English

MW (AM) TUNING STEP (SOME VERSIONS ONLY)

In North and South America the frequency step between adjacent channels in the AM band is **10 KHz**. In the rest of the world this step is **9 KHz**. Usually this frequency step has been preset in the factory of your area.

To change the tuning step

1. Adjust the CD TUNER TAPE/OFF slider to TAPE/OFF position.
 2. Press and hold down on BAND and SEARCH ◀◀ simultaneously to select **9 KHz**.
 3. Adjust the CD TUNER TAPE/OFF slider to TUNER position and then release the BAND and SEARCH ◀◀ controls
→ All preset stations will be lost and need to be programmed again.
- To select **10 KHz**, repeat steps **1-3** but use SEARCH ▶▶ instead.

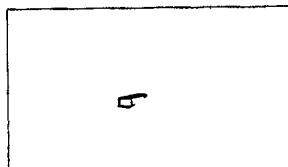

TUNING TO RADIO STATIONS

1. Adjust the CD TUNER TAPE/OFF slider to TUNER position
 2. Press BAND to select your wave band
To tune to radio stations, press the SEARCH ◀◀ or ▶▶ control until the frequency in the display starts running, then release the control
→ *Sr.ch* appears in the display and the radio automatically tunes to a station of sufficient reception.
 3. Repeat if necessary until you find the desired station.
- **To tune to a weak transmitter**, briefly press SEARCH ◀◀ or ▶▶ until you have found optimum reception or the correct frequency.
→ When **STEREO** appears in the display, you are receiving a FM-stereo transmitter.

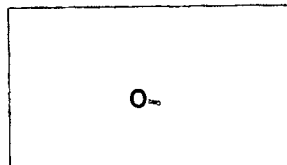
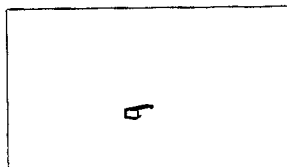

To improve radio reception

- For **FM**, pull out the telescopic aerial. Incline and turn the aerial. Reduce its length if the signal is too strong (very close to a transmitter).
- For **MW (AM)** and **LW**, the set is provided with a built-in aerial so the telescopic aerial is not needed. Direct the aerial by turning the whole set.

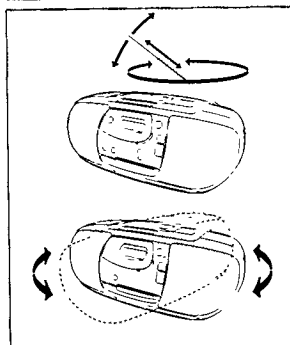
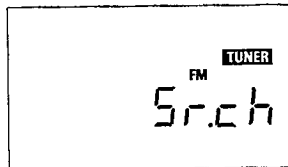

PROGRAMMING RADIO STATIONS

1. Tune to your desired station, following steps **1-3** under 'Tuning to radio stations'.
→ If the frequency is already stored in the memory, the preset number will be displayed.
2. Press PROG to activate programming.
→ **PROGRAM** flashes in the display.
3. Press the PRESET control (up or down) to allocate a preset station number from 1 to 29
4. Press PROG again to confirm the setting.
5. Repeat steps **1-4** to store all other presets.
 - You can clear a preset number by storing another frequency in its place

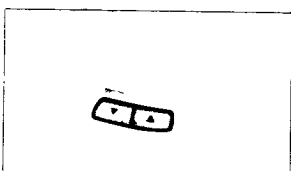
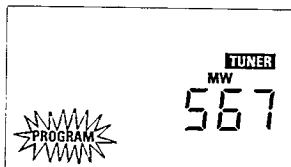
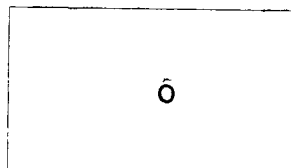

To deactivate programming mode

If during programming you decide not to programme a station, adjust the CD TUNER TAPE/OFF slider to CD or TAPE/OFF position

Tuning to preset stations

Press the PRESET \blacktriangledown , \blacktriangle control (down, up) until the desired number is shown.

DISPLAY INDICATION FOR CD FUNCTIONS

- cd OPEN*: when the CD door is opened
– Total track number and playing time: in stop mode.
- no disc*: when no disc is inserted.
- cd Err*: error in CD operation or with the CD (see 'Troubleshooting').
– Current track number and elapsed playing time: during CD playback.
– Elapsed playing time freezes and flashes: in PAUSE position.
– **SHUFFLE/REPEAT (ALL)** modes: when the respective mode is activated.
- PROGRAM**: programme mode is active
- PROG**: appears briefly and the selected track number (1-20) when you programme.
- FULL*: programme memory full.
- no Prog*:
– when you cancel a CD programme; you press PROG for more than two seconds but no track has been selected.
- no SEL*:
– when you press PROG for less than two seconds but no track has been selected.

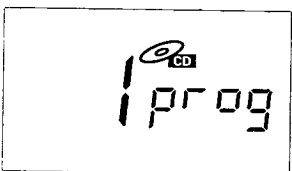
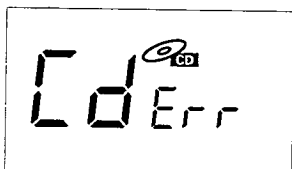
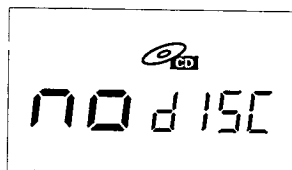

CD PLAYER

English

PLAYING A CD

1. Adjust the CD TUNER TAPE/off slider to CD position.
2. Press OPEN to open the CD compartment.
3. Insert a CD with the printed side facing up and close the compartment.
4. Press PLAY • PAUSE ►► to start playback.
5. To interrupt playback press PLAY • PAUSE ►►. To resume, press PLAY • PAUSE ►► again
6. To stop CD play, press STOP ■.
7. To switch off the set, adjust the slider to TAPE/off position (with the cassette keys released).

Note:

CD playback will also stop when:

- the CD door is opened;
- the CD has reached to the end;
- you move the CD TUNER TAPE/off slider

Selecting a different track

- On the set, press SEARCH ◀◀ or ▶▶ once repeatedly until the required track number appears in the display.
- If you have selected a track number shortly after loading a CD or in the PAUSE position, press PLAY • PAUSE ►► to start playback.

Finding a passage within a track

1. Press and hold down SEARCH ◀◀ or ▶▶.
→ The CD is played at high speed and low volume.
2. When you recognize the passage you want, release the SEARCH ◀◀ or ▶▶ button.

DIFFERENT PLAY MODES: SHUFFLE/REPEAT

You can select, change and combine different play modes before or during playback.

- The play modes can also be combined with PROGRAM.

SHUFFLE - All tracks of the entire CD or programme are played in random order.

SHUFFLE/REPEAT ALL - Repeats the entire CD or programme continuously in random order.

REPEAT - Plays the current track continuously.

REPEAT ALL - Repeats the entire CD or programme

1. To select your play mode, press SHUFFLE/REPEAT before or during playback until the desired function appears in the display.
 2. To return to normal playback press the respective SHUFFLE or REPEAT control until the various SHUFFLE/REPEAT modes are no longer shown in the display.
- You can also press STOP ■ to cancel your play mode.

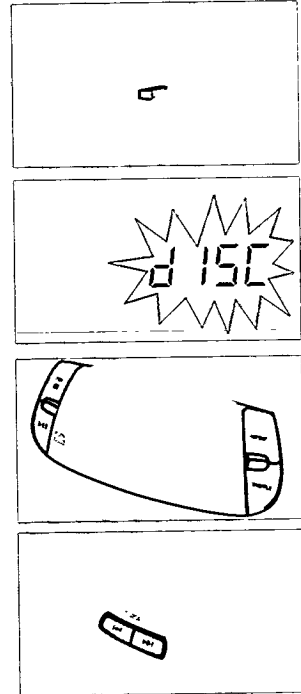

PROGRAMMING TRACK NUMBERS

Programme in the STOP position and store your CD tracks in any desired sequence. If you like, store any track more than once. Up to 20 tracks can be stored in the memory.

→ When the programme memory is full, **FULL** appears in the display and it will not be possible to add further tracks.

1. Use the SEARCH **◀◀** or **▶▶** to select your desired track number.
2. Press PROG
 - The display shows **PROGRAM** and the track number; **PROG** appears briefly.
3. Repeat steps 1 and 2 to select and store all desired tracks.
4. Press **PLAY • PAUSE ▶||** to start playback of your programme.

Reviewing your programme

- To review your set programme, keep PROG pressed for a few seconds.
 - The display will show in sequence all your stored track numbers.

Erasing a programme

You can erase the contents of the memory by:

- pressing STOP **■** twice;
- opening the CD door;
- moving the CD TUNER TAPE/OFF slider.

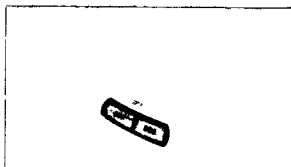
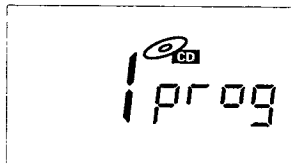

CASSETTE RECORDER

PLAYING A CASSETTE

1. Adjust the CD TUNER TAPE/OFF slider to TAPE/OFF position.
2. Press STOP • OPEN **■▲** to open the cassette holder.
3. Insert a cassette and close the cassette holder.
4. Press **PLAY ◀** to start playback.
5. To interrupt playback press **PAUSE ||**. To resume, press the key again.
6. By pressing **◀◀** or **▶▶**, fast winding of the tape is possible in both directions.
 - To stop fast winding, press STOP • OPEN **■▲**
7. To stop the tape, press STOP • OPEN **■▲**
 - The keys are automatically released at the end of the tape, except if PAUSE **||** has been activated.
8. To switch off the set make sure the cassette keys are released.

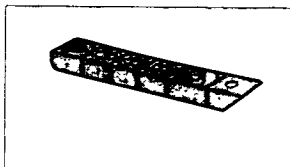
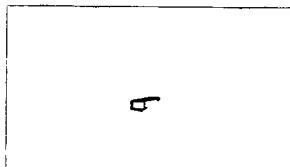

CASSETTE RECORDER

GENERAL INFORMATION ON RECORDING

- Recording is permissible insofar as copyright or other rights of third parties are not infringed.
- This deck is not suitable for recording on CHROME (IEC II) or METAL (IEC IV) type cassettes. For recording you should use NORMAL type cassettes (IEC I) on which the tabs have not been broken.
- The recording level is set automatically. Altering the VOLUME and bass controls will not affect the recording in progress.
- At the very beginning and end of the tape, no recording will take place during the 7 seconds, when the leader tape passes the recorder heads.
- To protect a tape from accidental erasure have the tape in front of you and break out the left tab. Recording on this side is no longer possible. To record over this side again, cover the tabs with a piece of adhesive tape.

Synchro Start CD recording

1. Adjust the CD TUNER TAPE/off slider to CD position.
2. Insert a CD and if desired, programme track numbers.
3. Press STOP•OPEN **■▲** to open the cassette holder.
4. Insert a blank tape and close the cassette holder.
5. Press RECORD **●** to start recording.
 - Playing of the CD programme starts automatically from the beginning of the programme. It is not necessary to start the CD player separately.
6. For brief interruptions, press PAUSE **||**. To resume recording, press PAUSE **||** again.
7. To stop recording press STOP•OPEN **■▲**

To select and record a particular passage

1. Press the SEARCH controls **◀◀** or **▶▶** to find your passage.
2. Press PLAY•PAUSE **▶||** to pause the CD.
3. Press RECORD **●** and recording will begin from this exact point in the track.

Recording from the radio

1. Adjust the CD TUNER TAPE/off slider to TUNER position.
2. Tune to the desired radio station using (See 'Tuning to radio stations').
3. Press STOP•OPEN **■▲** to open the cassette holder.
4. Insert a blank tape and close the cassette holder.
5. Press RECORD **●** to start recording.
6. For brief interruptions, press PAUSE **||**. To resume recording, press PAUSE **||** again.
7. To stop recording, press STOP•OPEN **■▲**

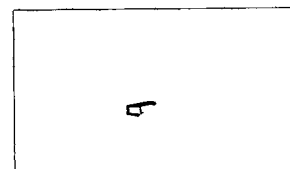
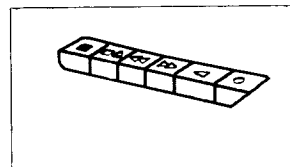
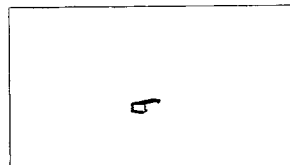
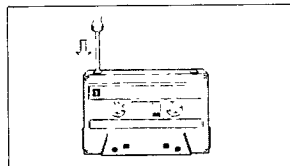

PRECAUTIONS AND SYSTEM MAINTENANCE

- Place the set on a hard, flat surface so that the system does not tilt
- Do not expose the set, CDs, batteries or cassettes to humidity, rain, sand or excessive heat caused by heating equipment or direct sunlight
- Do not cover the set. Adequate ventilation with a minimum gap of 15 cms between the ventilation holes and surrounding surfaces is necessary to prevent heat build-up.
- The mechanical parts of the set contain self-lubricating bearings and must not be oiled or lubricated.
- To clean the set, use a soft, slightly dampened chamois leather. Do not use any cleaning agents containing alcohol, ammonia, benzene or abrasives as these may harm the housing

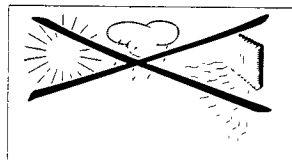

CD player and CD handling

- The lens of the CD player should never be touched.
- Sudden changes in the surrounding temperature can cause condensation to form and the lens of your CD player to cloud over. Playing a CD is then not possible. Do not attempt to clean the lens but leave the set in a warm environment until the moisture evaporates.
- Use only Digital Audio CDs
- To take a CD out of its box, press the centre spindle while lifting the CD. Always pick up the CD by the edge and replace the CD back in its box after use to avoid scratching and dust.
- To clean the CD, wipe in a straight line from the centre towards the edge using a soft, lint-free cloth. Do not use cleaning agents as they may damage the disc.
- Never write on a CD or attach stickers to it.

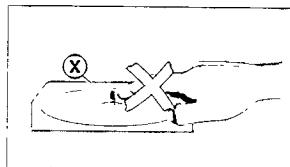

Tape deck maintenance

To ensure a good recording and playback of the tape deck, clean parts (A), (B) and (C) show in the diagram below, after approx. 50 hours of operation, or on average once a month. Use a cotton bud slightly moistened with alcohol or a special head cleaning fluid to clean both decks.

1. Open the cassette holder by pressing STOP•OPEN ■▲.
2. Press PLAY ◀ and clean the rubber pressure rollers (C).
3. Press PAUSE || and clean the magnetic heads (A) and also the capstans (B)
4. After cleaning, press STOP•OPEN ■▲.

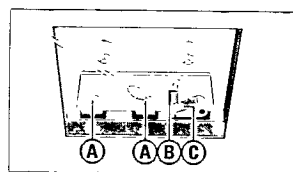

Note:

Cleaning of the heads can also be done by playing a cleaning cassette through once.

TROUBLESHOOTING

If a fault occurs, first check the points listed below before taking the set for repair. If you are unable to remedy a problem by following these hints, consult your dealer or service centre.

WARNING: Under no circumstances should you try to repair the set yourself, as this would invalidate the guarantee.

PROBLEM

– POSSIBLE CAUSE

- REMEDY

No sound/power

– VOLUME is not adjusted.

- Adjust the VOLUME.
- Headphones are connected.**
- Disconnect headphones.
- Mains lead not securely connected.**
- Connect the AC mains lead properly.
- Batteries exhausted.**
- Insert fresh batteries.
- Batteries incorrectly inserted.**
- Insert the batteries correctly.
- Batteries loaded but mains lead still plugged in and connected**
- Detach the mains plug from the MAINS socket and the set

Poor radio reception

– Weak radio signal

- **FM:** extend and aim the telescopic aerial for best reception;
- **MW (AM)/LW:** rotate the set

CD playback does not work

– CD is badly scratched or dirty.

- Replace or clean the CD, see Maintenance.
- Laser lens steamed up.**
- Wait until lens has acclimatized.

The CD skips tracks

– CD is damaged or dirty.

- Replace or clean the CD.
- SHUFFLE or PROGRAM is active.**
- Quit SHUFFLE/PROGRAM mode(s).

Poor cassette sound quality

– Dust and dirt on the heads, etc.

- Clean deck parts etc., see maintenance.
- Use of incompatible cassette types (METAL or CHROME).**
- Only use NORMAL (IEC I) for recording.

Recording does not work

– Cassette tab(s) may be broken out.

- Apply a piece of adhesive tape over the missing tab space.

This set complies with the radio interference requirements of the European Union.

The type plate is located on the bottom of the set.

AZ 1020 - CD Radio Cassette Recorder

Meet Philips at the Internet
<http://www.philips.com>

