

Register your product and get support at

www.philips.com/welcome

AE1120



EN User manual

PHILIPS

Contents

1	Important	3
<hr/>		
2	Your Portable Radio	4
	What's in the box	4
	Power supply	4
	Turn off	5
<hr/>		
3	Use your portable radio	5
	Listen to FM/MW radio	5
	Charge mobile phone	6
	Charge the Ni-MH battery pack	6
	Turn the flashlight on	7
	Turn the alarm on	7
<hr/>		
4	Product information	8
<hr/>		
5	Troubleshooting	8
<hr/>		
6	Notice	9

1 Important

- Read these instructions.
- Heed all warnings.
- Follow all instructions.
- Do not use this apparatus near water.
- Do not install near any heat sources such as radiators, heat registers, stoves, or other apparatus (including amplifiers) that produce heat.
- Only use attachments/accessories specified by the manufacturer.
- Refer all servicing to qualified service personnel. Servicing is required when the apparatus has been damaged in any way, such as liquid has been spilled or objects have fallen into the apparatus, the apparatus has been exposed to rain or moisture, does not operate normally, or has been dropped.
- Battery usage CAUTION – To prevent battery leakage which may result in bodily injury, property damage, or damage to the unit:
 - Install all batteries correctly, + and - as marked on the unit.
 - Do not mix batteries (old and new or carbon and alkaline, etc.).
 - Remove batteries when the unit is not used for a long time.
- Batteries (battery pack or batteries installed) shall not be exposed to excessive heat such as sunshine, fire or the like.
- Apparatus shall not be exposed to dripping or splashing.
- Do not place any sources of danger on the apparatus (e.g. liquid filled objects, lighted candles).

Always bring your product to a professional to remove the built-in battery. (Fig. ①)

①

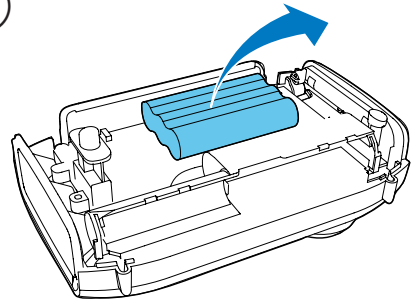

2 Your Portable Radio

Congratulations on your purchase, and welcome to Philips! To fully benefit from the support that Philips offers, register your product at www.philips.com/welcome.

What's in the box

Check and identify the contents of your package. (Fig. ②)

②

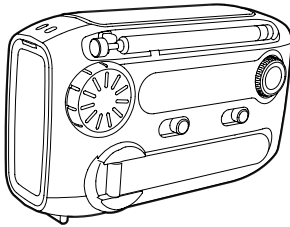

If you contact Philips, you will be asked for the model and serial number of this apparatus. The model number and serial number are on the bottom of the apparatus. Write the numbers here:

Model No. _____

Serial No. _____

Power supply



Caution

- The batteries contain chemical substances, so they should be disposed of properly.

To operate the portable radio, you can use either alkaline batteries or built-in Ni-MH battery pack.

Operate on alkaline batteries

- 1 Open the battery compartment.
- 2 Insert 3 × 1.5V AAA batteries (not supplied) with correct polarity (+/-) as indicated. (Fig. ③)

③

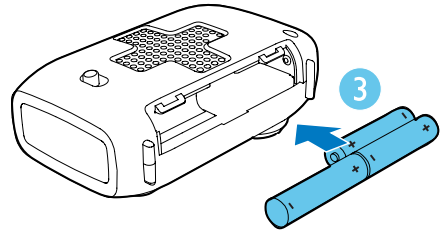
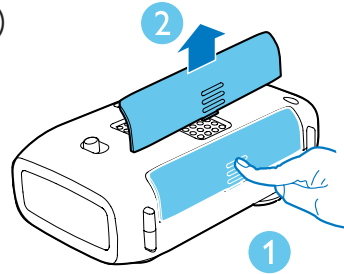

- 3 Close the battery compartment.
- 4 Slide the power source selector to **BATT.** (Fig. ④)
↳ The portable radio is operated on the alkaline batteries.

④

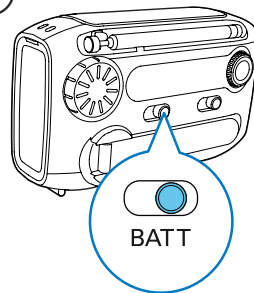

Tip

- To make sure that the built-in battery has enough power to support the alarm and flashlight function in emergency case, you are recommended to use alkaline batteries in normal times.

Operate on Ni-MH battery

To operate on the rechargeable Ni-MH battery pack, slide the power source selector to **RECHARGE BATT.** (Fig. ⑤)

⑤

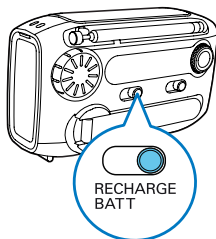

Turn off

After use, slide the power source selector to **OFF.**

3 Use your portable radio

Listen to FM/MW radio

- 1 Slide the power source selector to **BATT** (Fig. ④) or **RECHARGE BATT.** (Fig. ⑤)
- 2 Adjust the **FM•MW** slider to select FM or MW tuner.
- 3 Rotate the tuning knob to tune to a radio station.
- 4 Rotate the volume knob to adjust volume. (Fig. ⑥)

⑥

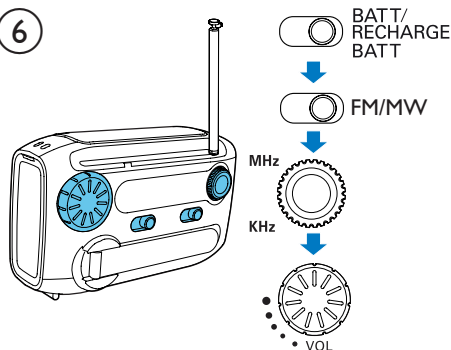

To achieve better radio reception:

- Position the antenna as far as possible from TV, VCR, or other radiation sources to prevent interference;
- Put the radio near window or in a spacious place.
- Change the length and direction of the antenna.

Tip

- To avoid radio interference, do not listen to the radio while charging your phone or built-in battery.

Charge mobile phone

This portable radio can also serve as an emergency charger for your mobile phone. In places where AC outlet is unavailable, your phone will never run out of power with this device.

- 1 Open the **MICRO USB** cover and take out the supplied USB cable.
- 2 Plug the USB cable into a USB socket on your phone. (Fig. ⑦)

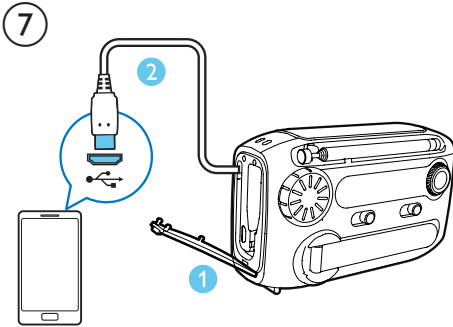

- 3 Slide the power source selector to **CHARGE MOBILE**. (Fig. ⑧)

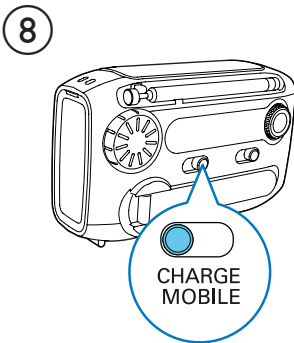

- 4 Pull out the **POWER GENERATOR**, then rotate it quickly to charge your phone. (Fig. ⑨)

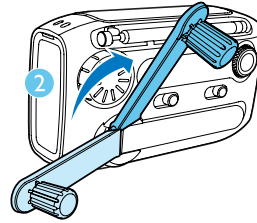
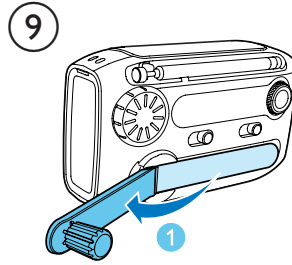

↳ The charging indication appears on your phone.

Note

- If the supplied USB cable does not match the USB socket on your phone, plug it into a USB converter (not supplied) first, and then connect to your phone.
- For some mobile phones that have special requirements on the charging current or voltage, charging may be unsuccessful.

Charge the Ni-MH battery pack

You have two ways to charge the built-in Ni-MH battery pack.

Charge through USB socket

- 1 Slide the power source selector to **OFF**, **BATT**, or **RECHARGE BATT**.
- 2 Connect a USB cable (not supplied) to :
 - the USB socket of your computer.
 - the USB socket of the portable radio. (Fig. ⑩)

- ↳ The portable radio begins charging the Ni-MH battery.

10

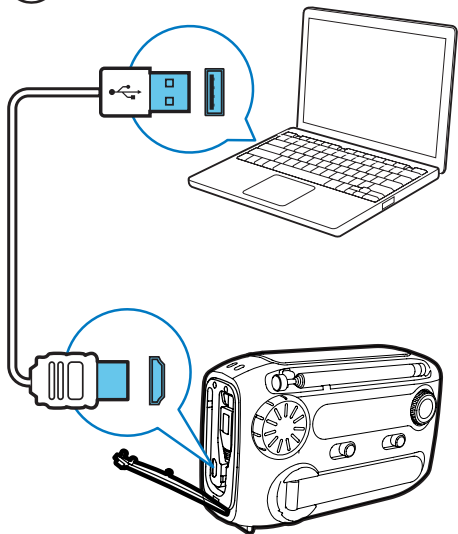

 Tip

- It takes 8 hours to fully charge the battery.
- Fully charge the built-in battery if the radio has not been used for more than 3 months.

Charge through power generator

In emergency situation, you can charge the built-in battery through the power generator:

- 1 Switch the power source selector to **OFF**, **BATT**, or **RECHARGE BATT**.
- 2 Pull out the **POWER GENERATOR**, then rotate it quickly to generate power. (Fig. 9)
↳ The generated power is stored in the Ni-MH battery.

Turn the flashlight on

(Fig. 10)

11

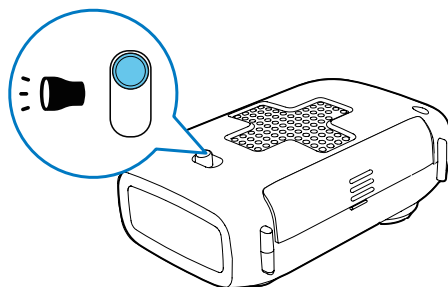

Turn the alarm on

(Fig. 12)

12

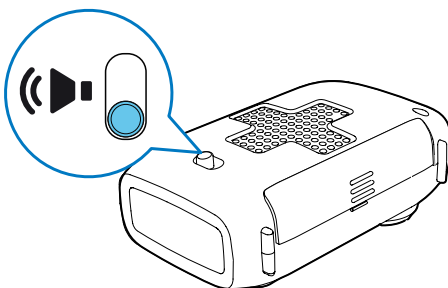

 Tip

- To avoid children being frightened by the sudden strident ringing, keep children away from the radio.

4 Product information

Note

- Product information is subject to change without prior notice.

Tuner

Tuning range	FM: 87.0 - 108 MHz MW: 522 - 1620 kHz
--------------	--

General information

Power supply

- Rechargeable battery Ni-MH battery pack
- Alkaline battery 3 X AAA batteries

Dimensions

- Main Unit (W x H x D)	120 x 76 x 47 mm
----------------------------	------------------

Weight

- With Packing	0.32 kg
- Main Unit	0.26 kg

5 Troubleshooting

Warning

- Never remove the casing of this device.

To keep the warranty valid, never try to repair the system yourself.

If you encounter problems when using this device, check the following points before requesting service. If the problem remains unsolved, go to the Philips Web page (www.philips.com/support). When you contact Philips, make sure that the device is nearby and the model number and serial number are available.

No power

- Make sure that you have selected the correct power source.
- Make sure that the alkaline batteries are installed properly.
- Charge the built-in battery.

Poor radio reception

- Keep the radio away from other electronic devices to avoid radio interference
- Change the length and direction of the antenna.

No sound

- Adjust the volume.

Cannot charge the phone or Ni-MH battery

- Rotate the power generator as fast as you can.
- Check if you have selected the correct power source.
- The USB cable does not match the USB socket of your phone. Try a USB convertor to connect your phone.
- Due to different product techniques of the mobile phone, charging may be unsuccessful.

6 Notice

Any changes or modifications made to this device that are not expressly approved by Philips Consumer Lifestyle may void the user's authority to operate the equipment.



This product complies with the radio interference requirements of the European Community.



Your product is designed and manufactured with high quality materials and components, which can be recycled and reused.



When this crossed-out wheeled bin symbol is attached to a product it means that the product is covered by the European Directive 2002/96/EC.

Please inform yourself about the local separate collection system for electrical and electronic products.

Please act according to your local rules and do not dispose of your old products with your normal household waste. Correct disposal of your old product helps to prevent potential negative consequences for the environment and human health.



Your product contains batteries covered by the European Directive 2006/66/EC, which cannot be disposed with normal household waste. Please inform yourself about the local rules on separate collection of batteries

because correct disposal helps to prevent negative consequences for the environmental and human health.



Note

- The type plate is located on the bottom of the apparatus.

Environmental information

All unnecessary packaging has been omitted. We have tried to make the packaging easy to separate into three materials: cardboard (box), polystyrene foam (buffer) and polyethylene (bags, protective foam sheet.)

Your system consists of materials which can be recycled and reused if disassembled by a specialized company. Please observe the local regulations regarding the disposal of packaging materials, exhausted batteries and old equipment.



Specifications are subject to change without notice
© 2012 Koninklijke Philips Electronics N.V.
All rights reserved.

AE1120_00_UM_V1.0

