

Register your product and get support at
www.philips.com/welcome

AC4006



User manual

PHILIPS



1

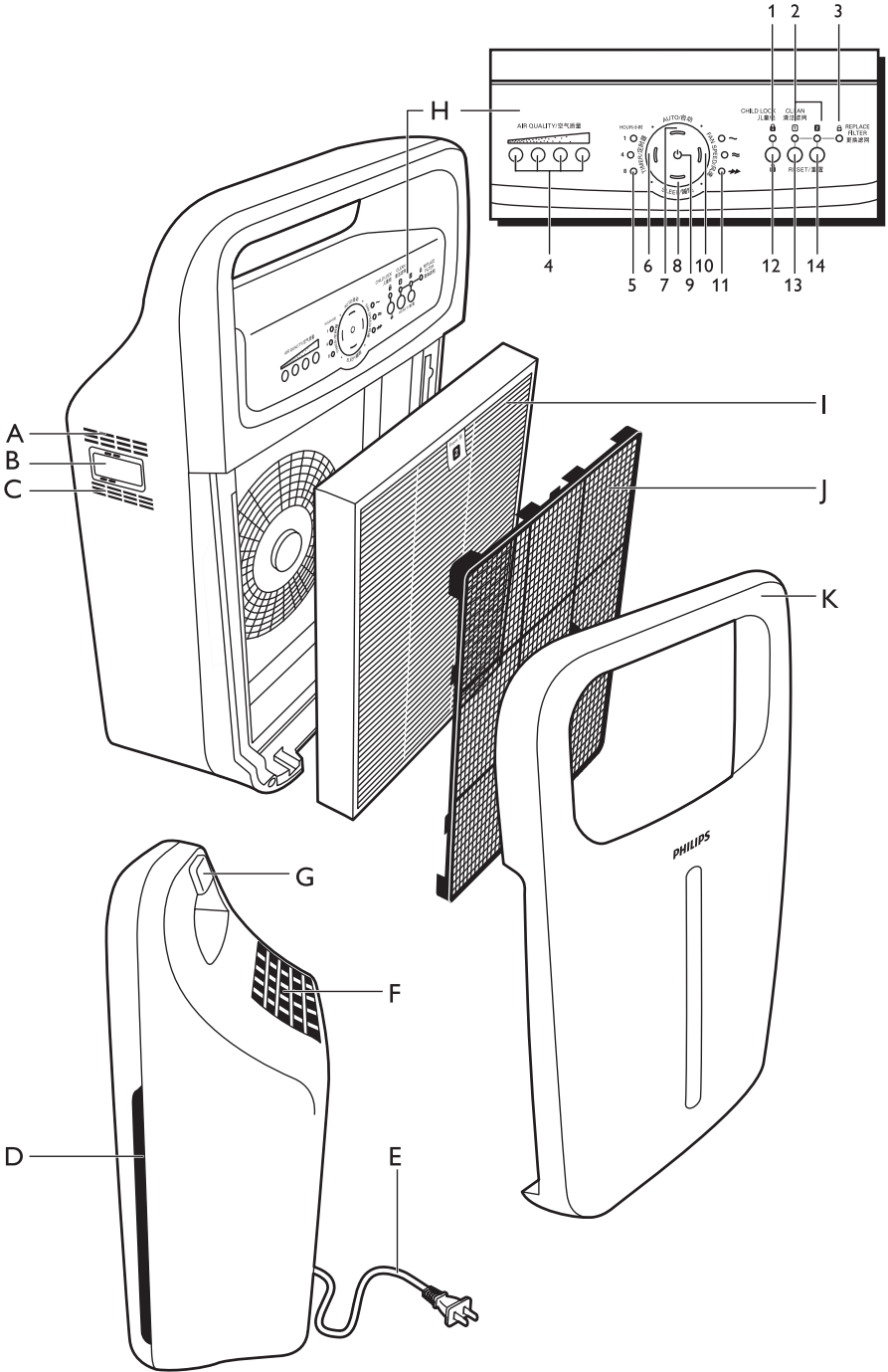

Introduction

Congratulations on your purchase and welcome to Philips! To fully benefit from the support that Philips offers, register your product at www.philips.com/welcome.

With this New home air purifier, you breathe cleaner air in your new or newly decorated home. For the best result, place the New home air purifier in a room where you spend most of your time, e.g. your bedroom, living room, or children's room.

There are many pollution sources. In a new or newly decorated home, there is high condensation of formaldehyde and other harmful gases coming from furniture, paints and smoking, and etc. Because of these harmful gases are invisible and odorless, they can affect your health. The New home air purifier filters off these harmful gases quickly and effectively. Furthermore, it can also filter out pollutants such as pollens, airborne particles that can affect your well-being. With our New home air purifier, it improves the air quality and ensures you and your family members breathe cleaner air at your home.

Filtration in a professional and credible way

The New home air purifier has all-in-one High capacity formaldehyde new home filter that ensures the best air quality in your new or newly decorated home:

- Stage 1: The pre-filter has been treated with antibacterial substances. It catches big particles like human hair, pet hair etc.
- Stage 2: The High capacity formaldehyde new home filter* effectively removes formaldehyde, odors, and other volatile organic compounds (VOCs).

* New home filter AC4125 supplied with AC4006.

General description (Fig. 1)

- A Air quality sensor outlet
- B Air quality sensor
- C Air quality sensor inlet
- D Air inlet
- E Mains cord
- F Air outlet
- G Handle
- H Control panel
 - 1 CHILD LOCK light
 - 2 Filter replacement lights
 - 3 REPLACE FILTER light with 'appliance locked' indication
 - 4 AIR QUALITY lights
 - 5 HOUR lights
 - 6 TIMER on/off button with light
 - 7 AUTO button with light
 - 8 SLEEP button with light
 - 9 Power on/off button with light
 - 10 FAN SPEED button with light
 - 11 BOOST POWER light
 - 12 CHILD LOCK button
 - 13 RESET button for filter 1
 - 14 RESET button for filter 2

- I Filter 2: High capacity formaldehyde / particle new home filter
- J Filter 1: pre-filter
- K Front panel

Important

Read this user manual carefully before you use the appliance and save it for future reference.

Danger

- Do not let water or any other liquid or flammable detergent enter the appliance to avoid electric shock and/or a fire hazard.
- Do not clean the appliance with water or any other liquid or a (flammable) detergent to avoid electric shock and/or a fire hazard.

Warning

- Check if the voltage indicated on the bottom of the appliance corresponds to the local mains voltage before you connect the appliance.
- If the mains cord is damaged, you must have it replaced by Philips, a service centre authorised by Philips or similarly qualified persons in order to avoid a hazard.
- Do not use the appliance if the plug, the mains cord or the appliance itself is damaged.
- This appliance is not intended for use by persons (including children) with reduced physical, sensory or mental capabilities, or lack of experience and knowledge, unless they have been given supervision or instruction concerning use of the appliance by a person responsible for their safety.
- Children should be supervised to ensure that they do not play with the appliance.
- Do not block the air inlet and outlet, e.g. by placing items on the air outlet or in front of the air inlet.

Caution

- This appliance is not a substitute for proper ventilation, regular vacuum cleaning or use of an extractor hood or fan while cooking.
- If the wall socket used to power the appliance has poor connections, the plug of the appliance may become hot. Make sure you plug the appliance into a properly connected wall socket.
- Always place and use the appliance on a dry, stable, level and horizontal surface.
- Leave at least 20cm free space behind and on both sides of the appliance and leave at least 30cm free space above the appliance.
- Do not place anything on top of the appliance and do not sit on the appliance.
- Do not place the appliance directly below an air conditioner to prevent condensation from dripping onto the appliance.
- Make sure all filters are properly installed before you switch on the appliance.
- Only use the original Philips filters specially intended for this appliance. Do not use any other filters.
- Avoid knocking against the appliance (the air inlet and outlet in particular) with hard objects.
- Always lift or move the appliance by the handgrip at the back of the appliance.
- Do not insert your fingers or objects into the air outlet.
- Do not use this appliance when you have used indoor smoke-type insect repellents or in places with oily residues, burning incense or chemical fumes.
- Do not use the appliance near gas appliances, heating devices or fireplaces.

- Always unplug the appliance after use and before you clean it.
- Do not use the appliance in a room with major temperature changes, as this may cause condensation inside the appliance.
- To prevent interference, place the appliance at least 2m away from electrical appliances that use airborne radio waves such as TVs, radios and radio-controlled clocks.
- When the air purifier is not used for a long time, bacteria may grow on the filters. Check the filters after a long period of disuse. If the filters are very dirty, replace them (see chapter 'Filter replacement').
- The appliance is only intended for household use under normal operating conditions.
- Do not use the appliance in wet surroundings or in surroundings with high ambient temperatures, such as the bathroom, toilet or kitchen.
- The appliance does not remove carbon monoxide (CO) or radon (Rn). It cannot be used as a safety device in case of accidents with combustion processes and hazardous chemicals.

Electromagnetic fields (EMF)

This Philips appliance complies with all applicable standards and regulations regarding exposure to electromagnetic fields.

Before first use

Placing the filters

The appliance comes with all filters fitted inside, but you have to remove the packaging of the filters before you can use the appliance. Remove all filters, unpack them and place them back into the appliance as described below.

Tip: Place the appliance against a wall for more stability when you remove or insert filters.

Note: Make sure you insert the filters in the correct position.

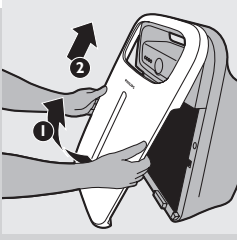

1 Place your fingers in the recesses of the side panels and gently pull the bottom of the front panel towards you. Then lift the hooks at the top of the panel out of the top of the appliance.

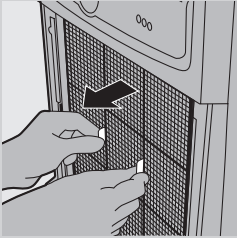

2 To remove the pre-filter, grab the two projections and pull the filter towards you.

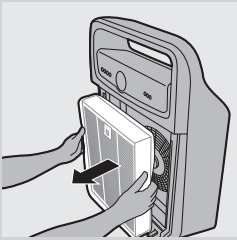

3 Remove the filter from the appliance.

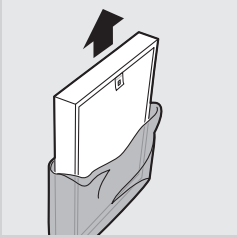

4 Take out the new filter from the packaging material.

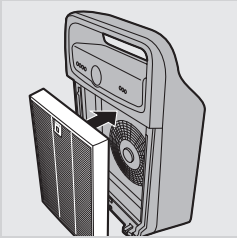

5 Put filter 2 (New home filter) back into the appliance.

Note: Make sure that the side with the tag points towards you.

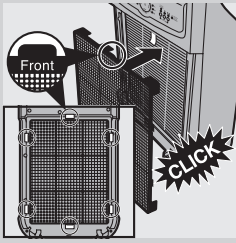

6 Place filter 1 (pre-filter) in the appliance.

Note: Make sure that the side with the two projections points towards you.

Note: Make sure that all hooks are properly attached to the appliance.

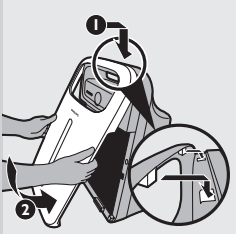

7 To reattach the front panel, insert the two hooks into the top of the appliance first (1). Then push the panel against the body of the appliance (2).

Using the appliance



1 Put the plug in the wall socket

► All lights go on and off twice and you hear a beep.

2 Press the on/off button to switch on the appliance.

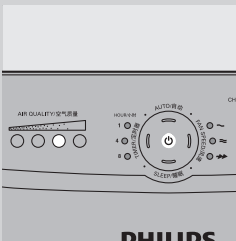

► The power-on light and one of the AIR QUALITY lights on the control panel goes on.

Colour	Air quality
Blue	Very good
Deep purple	Good
Purple	Fair
Red	Bad

- ▶ The appliance automatically starts operating in the auto mode.
To switch off the appliance, press the on/off button again and unplug the appliance.

Note: When the humidity level in the room is very high, it is possible that condensation develops on the air quality sensor. As a result, the AIR QUALITY lights on the control panel may indicate that the air quality is bad even though the air quality is good. In this case, the auto mode causes the appliance to run at high fan speed. You can solve this by cleaning the air quality sensor. If condensation develops frequently during periods of high humidity, we advise you to use one of the manual speed settings.

Auto mode

When the appliance is switched on, the built-in air quality sensor automatically measures the ambient air quality. When the auto mode is activated, the appliance selects the most appropriate fan speed for the measured air quality.

Note: When you use the auto mode, you can also use the timer function (see section 'Timer function in this chapter'). In this case, the AUTO light, one of the FAN SPEED lights, the TIMER light and one of the HOUR lights are on.

- 1 Press the on/off button to switch on the appliance.
- ▶ The appliance automatically starts operating in the auto mode.

Note: When the appliance is operating in another mode and you want to activate the auto mode, simply press the AUTO button.

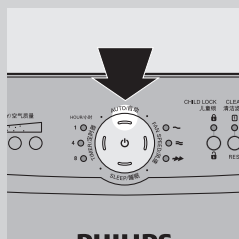

- ▶ The AUTO light and one of the FAN SPEED lights go on. The FAN SPEED light indicates at which fan speed the appliance is operating.

Note: When the air quality is very good and the fan speed operates at a very low fan speed, the FAN SPEED light for the lowest speed level does not go on. In this case only the power-on light and the AUTO light are on.

Note: The built-in air quality sensor measures the air quality and automatically selects the appropriate speed setting to ensure the best possible air quality in your room. When the air is clean, the appliance stops running. When the air quality deteriorates, the appliance starts running at a low fan speed and noise level so that the energy consumption is minimised.

Fan speed

If you do not use the auto mode, you can select the desired fan speed yourself.

Note: When you manually select a fan speed, you can also use the timer function (see section 'Timer function in this chapter'). In this case, one of the FAN SPEED lights, the TIMER light and one of the HOUR lights are on.

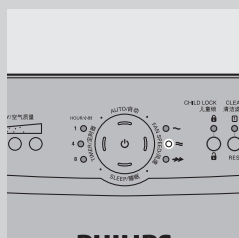

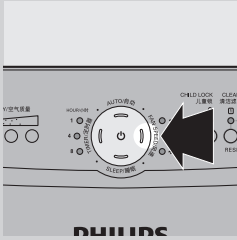

- 1** Press the on/off button to switch on the appliance.
- 2** Press the FAN SPEED button one or more times to select the desired fan speed.
 - ▶ The corresponding FAN SPEED light shows the set fan speed.

Timer function

With the timer function, you can let the appliance operate for a set number of hours. When the set time has elapsed, the appliance automatically switches off.

You can use the timer function in a number of situations:

- In combination with the AUTO mode (see section 'Auto mode' in this chapter). In this case, the AUTO light, one of the FAN SPEED lights, the TIMER light and one of the HOUR lights are on.
- When you choose a fan speed manually (see section 'Fan speed' in this chapter). In this case, one of the FAN SPEED lights, the TIMER light and one of the HOUR lights are on.
- In combination with the SLEEP mode (see section 'Sleep mode' in this chapter). In this case, the SLEEP light and one of the HOUR lights are on (but dimmed).

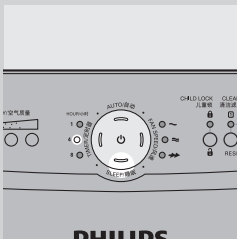
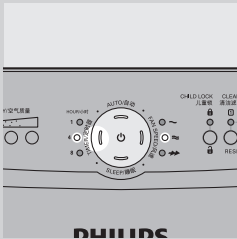
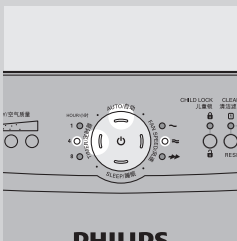

- 1** Press the on/off button to switch on the appliance.
- 2** Press the TIMER button to activate the timer.
 - ▶ The TIMER light goes on.
- 3** Press the TIMER button repeatedly to choose the number of hours you want the appliance to operate.
 - ▶ The corresponding HOUR light goes on.

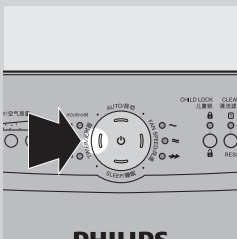

To deactivate the timer function, press the TIMER button repeatedly until the HOUR light and the TIMER light are out.

Sleep mode

When you use the appliance in sleep mode, it operates very quietly and all the lights that are on are dimmed, to allow you to sleep undisturbed.

Note: When you use the sleep mode, you can also use the timer function (see section 'Timer function in this chapter'). In this case, the SLEEP light and one of the HOUR lights are on (but dimmed).

- 1** Press the on/off button to switch on the appliance.
- 2** Press the SLEEP button to activate the quiet sleep mode.
 - ▶ The SLEEP light dims.
 - ▶ All other lights are off, except one of the HOUR lights if you have activated the timer function.

If you want to go back to the fan speed mode or auto mode, simply press the FAN SPEED or AUTO button. The sleep mode is then deactivated.

Adjusting the air quality sensor sensitivity

People with certain health problems (e.g. allergies or asthma) have a greater need for healthy air. For this reason, the air purifier allows you to adjust the sensitivity of the air quality sensor. If you set it to higher sensitivity level, the appliance starts cleaning the air at lower pollution level.

There are 3 sensitivity levels:

- extra sensitive
- sensitive
- standard

The air quality sensor is set to standard sensitivity by default. You can adjust the sensitivity of the air quality sensor in the following way:

- 1** If the appliance is already plugged in, unplug the appliance and wait for a few minutes.
- 2** Press and hold the TIMER button and simultaneously put the mains plug in the wall socket.
 - ▶ The appliance beeps twice and one of the HOUR lights flashes to show the current sensitivity level of the air quality sensor.

Sensitivity level:

HOUR light

1hr

4hrs

8hrs

Sensitivity level

extra sensitive

sensitive

standard

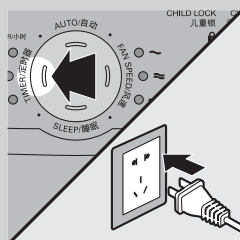
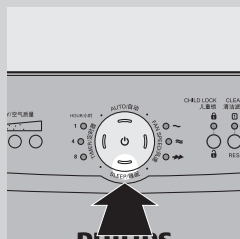

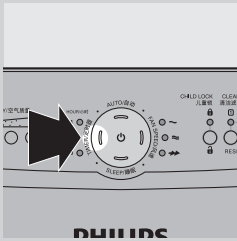

- 3** Press the **TIMER** button to adjust the sensitivity level of the air quality sensor.
 - ▶ One of the **HOUR** lights flashes to show the set sensitivity level of the air quality sensor.

- 4** Press the on/off button to switch off the appliance.

Note: When you change the sensitivity level, the appliance automatically starts operating at the set sensitivity level whenever you switch on the appliance.

Child lock

To prevent small children from operating the air operating air purifier, you can set the child lock function.

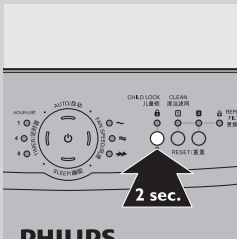

- 1** Press and hold the **CHILD LOCK** button.
 - ▶ The appliance beeps and all buttons are locked except the **CHILD LOCK** button. The **CHILD LOCK** light lights up.
- 2** Press and hold the **CHILD LOCK** button to switch off the appliance.

Note: The CHILD LOCK function can be activated in standby mode as long as the appliance is plugged in.

Note: Make sure the CHILD LOCK is deactivated before you switch off the appliance.

Cleaning and maintenance

Always unplug the appliance before you clean it.

Never immerse the appliance in water or any other liquid.

Never use aggressive or flammable cleaning agents such as bleach or alcohol to clean any part of the appliance.

Only the pre-filter is washable.

Body of the appliance

Regularly clean the inside and outside of the body to prevent dust from collecting on the inside and outside.

- 1** Wipe away dust with a soft dry cloth from the body of the appliance.
- 2** Clean the air inlet and the air outlet with a soft dry cloth.

Pre-filter

The pre-filter is washable.

- Clean the pre-filter when the filter cleaning light flashes to ensure optimal functioning of the appliance.

1 Unplug the appliance.

2 Place your fingers in the recesses of the side panels and gently pull the bottom of the front panel towards you. Then lift the hooks at the top of the panel out of the top of the appliance.

3 To remove the pre-filter, grab the two projections and pull the filter towards you.

4 Wash the pre-filter under a running tap. If the pre-filter is very dirty, use a soft brush to brush away the dirt.

Tip: Alternatively, you can clean the pre-filter by removing the dust with a vacuum cleaner.

5 Air-dry the pre-filter.

Note: Make sure that the pre-filter is completely dry.

6 Put the pre-filter back into the appliance. Attach all hooks properly to the appliance.

Note: Make sure that the side with the two projections is pointing towards you.

7 To reattach the front panel, insert the two hooks into the top of the appliance first (1). Then push the panel against the body of the appliance (2).

8 Put the plug in the wall socket.

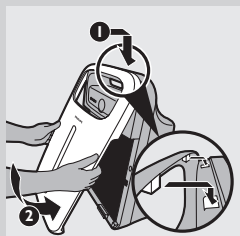
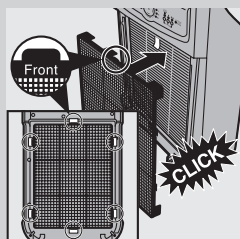
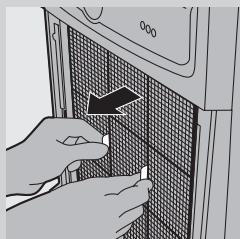
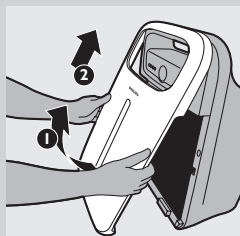
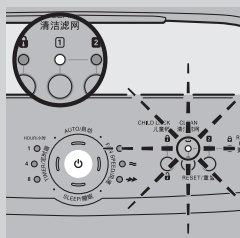

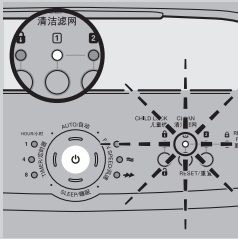

- 9 Press and hold the reset button for filter 1 (the button below the filter cleaning light) for 2 seconds to reset the appliance.

Air quality sensor

Clean the air quality sensor every 2 months for optimal functioning of the appliance. Clean it more frequently if you use the appliance in a dusty environment.

Note: When the humidity level in the room is very high, it is possible that condensation develops on the air quality sensor. As a result, the AIR QUALITY light on the control panel may indicate that the air quality is bad even though the air quality is good. In this case you have to clean the air quality sensor or use one of the manual speed settings.

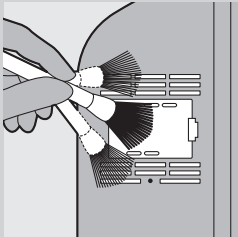

- 1 Clean the air quality sensor inlet and the air quality sensor outlet with a soft brush.

- 2 Remove the air quality sensor cover.

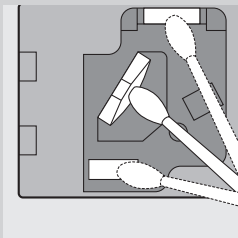
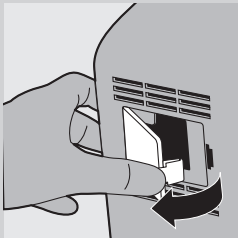

- 3 Clean the air quality sensor, the dust inlet and the dust outlet with a lightly moistened cotton swab.

- 4 Dry them with a dry cotton swab.

- 5 Reattach the air quality sensor cover.

Filter replacement

Filter maintenance

When one of the filters is almost full and has to be cleaned or replaced, the corresponding light or lights (the pre-filter cleaning light or one of the filter replacement lights together with the 'REPLACE FILTER' light) start to flash. You then have to clean or replace this filter.

This air purifier is also equipped with the Healthy air protect lock to ensure that the filters are in optimal condition when the appliance is operating. When you do not replace filter 2 (New home filter), the appliance stops operating and the appliance is locked. When the appliance is locked, the filter replacement light of the filter concerned and the 'REPLACE FILTER' light flash up continuously.

Filter cleaning light and filter replacement lights

The filter cleaning light and the filter replacement lights indicate which filter has to be cleaned or replaced.

- Filter cleaning light 1 flashes: you have to clean filter 1 (pre-filter). See chapter 'Cleaning' for further instructions.

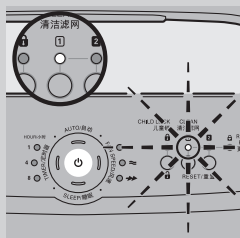

- Filter replacement light 2 and the 'REPLACE FILTER' light flash: filter 2 New home filter has to be replaced.

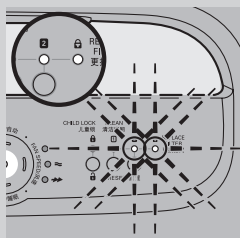

Healthy air protect lock

If you do not replace a filter in time, the appliance stops operating approx. 2 weeks after the filter replacement light started flashing. When the appliance is locked, it does not operate until you have replaced with the new filter and pressed the reset button.

Note: When the power on/off light, filter replacement light 2 and the 'REPLACE FILTER' light are on continuously, the appliance is locked (see section 'Filter maintenance' in this chapter for more information).

Approximately 1 day before the appliance locks, it beeps every 30 minutes to inform you that one of the filters needs to be replaced.

When the appliance is locked, you hear a beep when you press any button. You can switch off the appliance by pressing and holding the on/off button. If the appliance is locked:

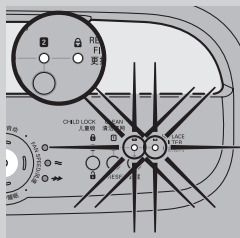

- 1** Check which filter needs to be replaced (see section 'Filter cleaning light and filter replacement lights' above).
- 2** Switch off the appliance and unplug it.
- 3** Replace the appropriate filter (see section 'Replacing the filters and resetting the appliance' below).

Replacing the filters and resetting the appliance

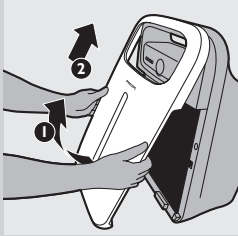

Tip: Place the appliance against a wall for more stability when you remove or insert filters.

- 1** Switch off the appliance and unplug it.
- 2** Place your fingers in the recesses of the side panels and gently pull the bottom part of the front panel towards you. Then lift the hooks at the top of the panel out of the top of the appliance.

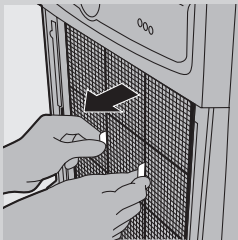

- 3** To remove filter 1 (pre-filter), grab the two projections and pull the filter towards you.

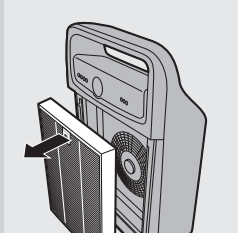

- 4** To remove filter 2 (New home filter), grab its tag and pull it towards you.
- 5** Discard the filter that has to be replaced and unpack the new filter.

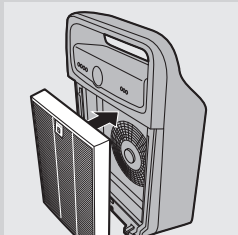

- 6** Put filter 2 (New home filter) back into the appliance.

Note: Make sure that the side with the tag points towards you.

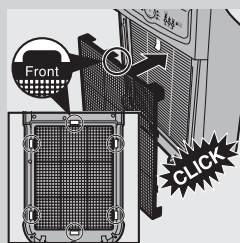

7 Put filter 1 (pre-filter) back into the appliance.

Note: Make sure that the side with the two projections points towards you.

Note: Make sure that all hooks are properly attached to the appliance.

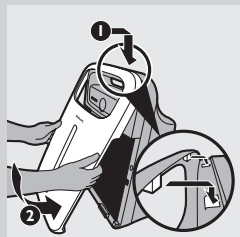

8 To reattach the front panel, insert the two hooks into the top of the appliance first (1). Then push the panel against the body of the appliance (2).

9 Put the plug in the wall socket and switch on the appliance again.

10 Press and hold the reset button below the filter replacement light of the filter you have replaced to reset the appliance.

- Press and hold the reset button for filter 2 for 2 seconds if you have replaced filter 2 (New home filter).
- ▶ You hear a beep and the appliance starts operating in the auto mode again.

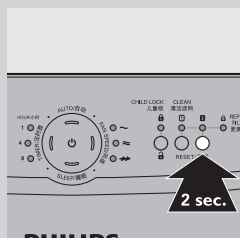

Accessories

New filters are available under the following type numbers:

Filter	Type number
--------	-------------

Filter 2: High capacity formaldehyde/ particle new home filter	AC4125
--	--------

Environment



- Do not throw away the appliance with the normal household waste at the end of its life, but hand it in at an official collection point for recycling. By doing this, you help to preserve the environment.

Guarantee and service

If you need information or if you have a problem, please visit the Philips website at www.philips.com or contact the Philips Consumer Care Centre in your country (you find its phone number in the worldwide guarantee leaflet). If there is no Consumer Care Centre in your country, go to your local Philips dealer.

Troubleshooting

This chapter summarises the most common problems you could encounter with the appliance. If you are unable to solve the problem with the information below, contact the Consumer Care Centre in your country.

Problem	Possible solution
Child lock and other buttons are not responding.	Replace the New home filter when the REPLACE FILTER light started flashing and the appliance has sounded every 30 minutes after approx. 2 weeks. Replace the filter and reset the appliance (see chapter 'Filter replacement') so that the appliance can provide healthy air again.
The AIR QUALITY lights keep flashing and the appliance does not work.	There is a problem with the air quality sensor of the appliance. Please contact the Philips Consumer Care Centre in your country (you find its phone number in the worldwide guarantee leaflet). If there is no Consumer Care Centre in your country, go to your local Philips dealer.
No air comes out of the air outlet	The appliance is not switched on. Put the plug in the wall socket and switch on the appliance. The air quality is good and the auto mode is activated. In this case, the appliance stops operating automatically when the air is clean to save electricity.
The airflow that comes out of the air outlet is significantly weaker than before.	The pre-filter is dirty. Clean the pre-filter (see chapter 'Cleaning').
The air quality does not improve, even though the appliance has been operating for a long time.	You haven't removed all packaging material from the filters. Make sure that you have removed all packaging material. One of the filters has not been placed in the appliance. Make sure that all filters are properly installed in the following order, starting with the innermost filter: New home filter has to be attached to the back of the pre-filter. The air quality sensor is wet. The humidity level in your room is high and causes condensation. Make sure that the air quality sensor is clean and dry (see chapter 'Cleaning').
The AIR QUALITY light does not change colour even though the appliance has been operating for some time.	The air quality sensor is dirty. Clean the air quality sensor (see chapter 'Cleaning').

Problem	Possible solution
I need cleaner air because I have an allergy.	You can change the air quality sensor sensitivity (see chapter 'Using the appliance') to make the air purifier clean the air even better.
The appliance is extra loud.	You have not removed all packaging material from the filters. Make sure that you have removed all packaging material.
The appliance still indicates that I need to replace a filter, but I already did.	Perhaps you did not reset the appliance. Plug in the appliance, press and hold the reset button corresponding to the filter you have replaced. The appliance beeps if you have reset it properly.
When I press the SLEEP button, all lights except for the SLEEP light go out.	When you press the SLEEP button, the appliance enters the SLEEP mode, which is designed to allow you to sleep undisturbed. The appliance operates quietly and only the SLEEP light is on. If you have activated the timer, one of the HOUR lights is also on. All lights that are on in the SLEEP mode are dimmed to allow you to sleep undisturbed.
The appliance stops operating, although the power-on light is still on.	The built in quality sensor has determined that the air quality is good and that the air does not need to be cleaned anymore. When the air quality deteriorates, the appliance starts running at a low fan speed and noise level so that the energy consumption is minimised.
The appliance does not work. The air quality light ring flashes blue, all other lights are out.	This is air particle sensor error or an air particle sensor and gas sensor error: Contact the Consumer Care Centre in your country (you find its phone number in the worldwide guarantee leaflet). If there is no Consumer Care Centre in your country, go to your local Philips dealer.
All function buttons are not responding.	Perhaps you activated the child lock function. Press the child lock button to release the lock

PHILIPS

产品 : 飞利浦空气净化器
型号 : AC4006
额定电压 : 220V~
额定频率 : 50Hz
额定输入功率: 40 W
生产日期 : 请见产品背部
产地 : 中国



制造商: 飞利浦电子香港有限公司
香港新界沙田香港科学园科技道东五号

经销单位: 飞利浦(中国)投资有限公司
上海市天目西路218号1602-1605
全国顾客服务热线: 4008 800 008

本产品根据国标GB4706.1-2005,GB4706.45-2008制造

请妥善保管本用户手册

