

Register your product and get support at  
[www.philips.com/welcome](http://www.philips.com/welcome)

LED TV

32PFH4309  
32PFH4399  
32PFT4309  
32PFT4309  
32PHH4309  
32PHH4309  
32PHH4319  
32PHH4329  
32PHT4309  
32PHT4319  
40PFH4309  
40PFH4319  
40PFH4329  
40PFH4399  
40PFT4309  
40PFT4309  
40PFT4319  
40PFT4319  
50PFH4309  
50PFH4319  
50PFH4329  
50PFT4309  
50PFT4319

# 用户手册

**PHILIPS**

# 内容

- 1 您的全新电视 3
  - 1.1 暂停电视和录制 3
  - 1.2 EasyLink 3
- 2 设置 4
  - 2.1 阅读安全说明 4
  - 2.2 电视支架和壁挂式安装 4
  - 2.3 安装提示 4
  - 2.4 电源线 4
  - 2.5 天线 5
- 3 连接 6
  - 3.1 连接提示 6
  - 3.2 EasyLink HDMI CEC 7
  - 3.3 通用接口 - CAM 8
  - 3.4 机顶盒 - STB 8
  - 3.5 卫星接收器 8
  - 3.6 家庭影院系统 - HTS 9
  - 3.7 蓝光光盘播放机 10
  - 3.8 DVD 播放机 10
  - 3.9 游戏控制台 10
  - 3.10 USB 硬盘驱动器 11
  - 3.11 USB 闪存盘 11
  - 3.12 摄像机 12
  - 3.13 电脑 12
  - 3.14 耳机 13
- 4 打开 14
  - 4.1 开机或待机 14
- 5 遥控器 15
  - 5.1 键概述 15
  - 5.2 红外传感器 15
  - 5.3 电池 15
  - 5.4 清洁 16
- 6 电视频道 17
  - 6.1 观看电视频道 17
  - 6.2 频道安装 20
- 7 电视指南 24
  - 7.1 使用电视指南 24
  - 7.2 录音 24
  - 7.3 接收电视指南数据 24
- 8 来源 25
  - 8.1 来源列表 25
  - 8.2 从待机模式 25
  - 8.3 EasyLink 25
- 9 定时器和时钟 26
  - 9.1 定时关机 26
  - 9.2 时钟 26
  - 9.3 自动关熄 26
- 10 您的照片、视频和音乐 27
  - 10.1 来自 USB 连接 27
- 11 Pause TV 29
  - 11.1 Pause TV 29
- 12 录制 30
  - 12.1 您需要执行的操作 30
  - 12.2 录制节目 30
  - 12.3 观看录制 30
- 13 设置 31
  - 13.1 画面 31
  - 13.2 游戏或电脑 32
  - 13.3 格式和边缘 32
  - 13.4 声音 32
- 14 规格 35
  - 14.1 环境 35
  - 14.2 PxHxxx9/PxTxxx9 的接收 35
  - 14.3 显示屏 35
  - 14.4 功率 36
  - 14.5 尺寸和重量 \_43x9 36
  - 14.6 连接 36
  - 14.7 多媒体 37
- 15 软件 38
  - 15.1 软件更新 38
  - 15.2 软件版本 38
  - 15.3 开放源软件 38
  - 15.4 Open source license 38
- 16 故障排除和支持 59
  - 16.1 故障检修 59
  - 16.2 注册 60
  - 16.3 帮助 60
  - 16.4 在线帮助 60
  - 16.5 客户服务/维修 60
- 17 安全与维护 61
  - 17.1 安全 61
  - 17.2 屏幕保养 62
- 18 用条款、版权和授权 63
  - 18.1 使用条款 63
  - 18.2 版权和许可 63
- 索引 64

---

# 您的全新电视

---

## 1.1

### 暂停电视和录制

如果您连接了 USB 硬盘驱动器，则可以暂停和录制数字电视频道的广播。



暂停电视并接听紧急电话，或者在体育比赛期间休息片刻，让电视将广播存储在 USB 硬盘驱动器上。稍后您可以继续开始观看。

---

## 1.2

### EasyLink

有了 EasyLink，您可以使用电视遥控器操作连接的设备，如蓝光光盘播放机。

EasyLink 使用 HDMI CEC 与连接的设备通信。

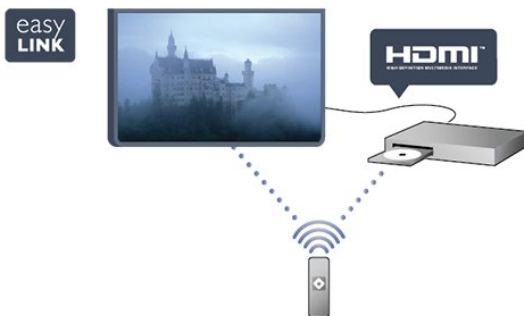

# 设置

## 2.1

### 阅读安全说明

使用电视前，请先阅读安全说明。

在“帮助”中，转至安全和关怀 > 安全。

## 2.2

### 电视支架和壁挂式安装

#### 电视支架

可以在电视机随附的快速入门指南中找到安装电视支架的说明。万一您遗失了此指南，可以从 [www.philips.com](http://www.philips.com) 下载。

使用电视的产品型号查找要下载的快速入门指南。

#### 壁挂式安装

您的电视还准备了符合 VESA 标准的壁挂安装支架（单独出售）。

购买壁挂安装支架时，请使用以下 VESA 代码：要牢牢固定支架，请使用图中所示长度的螺钉。

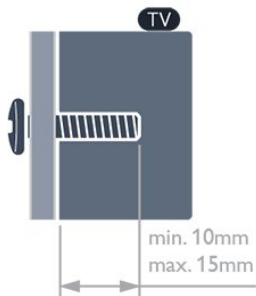

- 32Pxx43x9 - VESA MIS-F 100x100, M4
- 40Pxx43x9 - VESA MIS-F 200x200, M4
- 50Pxx43x9 - VESA MIS-F 400x200, M6

#### 注意

壁挂安装电视需要特殊技能，应该只能由有资质的人员执行。根据电视机的重量，电视壁挂式安装应符合安全标准。另外安置电视前，请先阅读安全警告。

TP Vision Europe B.V.

对于由于安装不当而造成的事故或人身伤害不负任何责任。

#### 壁挂式安装

您的电视还准备了符合 VESA 标准的壁挂安装支架（单独出售）。

购买壁挂安装支架时，请使用以下 VESA 代码：要牢牢固定支架，请使用图中所示长度的螺钉。

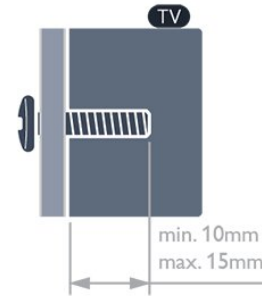

- 42Pxx5199 - VESA MIS-F 200x200, M6
- 47Pxx5199 - VESA MIS-F 400x400, M6
- 55Pxx5199 - VESA MIS-F 400x400, M6

#### 注意

壁挂安装电视需要特殊技能，应该只能由有资质的人员执行。根据电视机的重量，电视壁挂式安装应符合安全标准。另外安置电视前，请先阅读安全警告。

TP Vision Europe B.V.

对于由于安装不当而造成的事故或人身伤害不负任何责任。

## 2.3

### 安装提示

- 将电视放在光线不会直射到屏幕的地方。
- 将电视放在距离墙壁最多 15 厘米的位置。
- 观看电视的理想距离是电视屏幕对角长度的 3 倍。就坐时，眼睛应与屏幕中心持平。

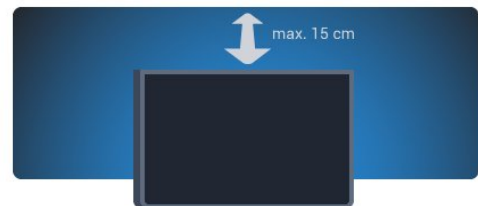

## 2.4

### 电源线

- 将电源线插入电视背面的 POWER（电源）接口。
- 确保电源线牢固插入接口。
- 确保可随时使用电源插座中的电源插头。
- 拔出电源线时，始终应拔动插头，切勿拉扯线缆。

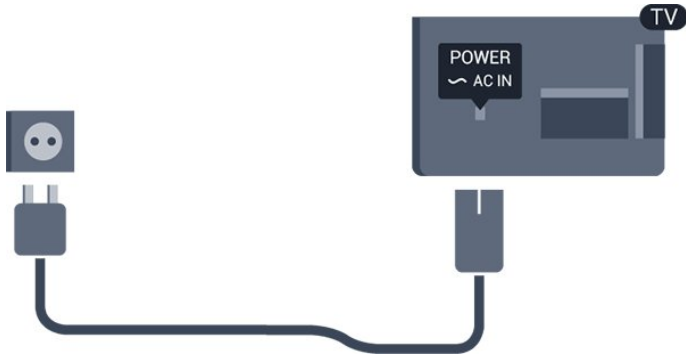

尽管本电视待机功耗低，但如果长时间不使用电视，请拔掉电源线以节约能源。

---

## 2.5

# 天线

将天线插头牢牢插入电视背面的 ANTENNA (天线) 插孔。

您可以连接自己的天线，或者来自天线分配系统的天线信号。请使用 IEC 同轴 75 Ohm RF 天线接头。

使用此天线接口可获得 DVB-T 和 DVB-C 输入信号。



# 连接

## 3.1

### 连接提示

#### 连接指南

务必通过可用的最高质量连接将设备连接到电视。另外，请使用质量良好的网线，以确保画面和声音传输良好。

如果在将多台设备连接到电视时需要帮助，可以访问飞利浦电视连接指南。该指南提供了如何连接以及应使用哪种网线的信息。

转到 [www.connectivityguide.philips.com](http://www.connectivityguide.philips.com)

#### 天线

如果您有机顶盒（数字接收器）或录像机，那么可以连接天线电缆，以使天线信号先通过机顶盒和/或录像机，然后再进入电视。这样一来，天线和机顶盒可将其他频道发送到录像机，以便进行录制。

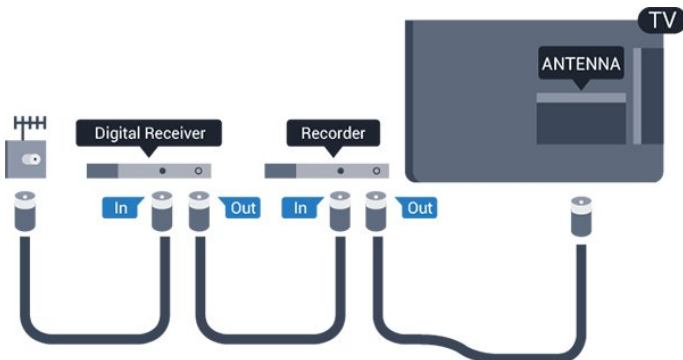

#### HDMI

##### HDMI CEC

HDMI 连接有最佳的图像和声音质量。一根 HDMI 电缆同时混合视频和音频信号。使用 HDMI 电缆可传输高清 (HD) 或全高清 (FHD) 电视信号。如需信号质量最佳的传输，请使用高速 HDMI 电缆，且不要使用长度超过 5 米的 HDMI 电缆。

**HDMI**  
HIGH-DEFINITION MULTIMEDIA INTERFACE



##### EasyLink HDMI CEC

如果您的设备连接了 HDMI，并且有 EasyLink，那么可以用电视遥控器操作它们。EasyLink HDMI CEC 必须在电视和连接的设备上开启。

##### DVI 至 HDMI

如果设备只有 DVI 接口，可以使用 DVI 至 HDMI 适配器。请使用一个 HDMI 接口，将 AUDIO L/R 电缆（3.5 毫米迷你插孔）添加到电视背面的 AUDIO IN 以获得声音。

##### 复制保护

##### DVI 和 HDMI 电缆支持

HDCP（高带宽数字内容保护）。HDCP 是防止从 DVD 光盘或蓝光光盘复制内容的复制保护信号。也称为 DRM（数字版权管理）。

##### HDMI ARC

电视上的 HDMI 1 接口具有 HDMI ARC（音频回传通道）。如果设备（通常是家庭影院系统 (HTS)）也有 HDMI ARC 接口，请将其连接到此电视机上的 HDMI 1。有了 HDMI ARC 连接，就无需再连接向 HTS 发送电视画面声音的额外音频电缆。HDMI ARC 连接已混合这两种信号。

如果更希望关闭 HDMI 接口上的 ARC，请按 **Home**，然后选择设置，再按 **OK**。选择电视设置 > 声音 > 高级 > HDMI 1 - ARC。

##### Scart

SCART 是质量良好的连接。SCART 连接可用于 CVBS 和 RGB 视频信号，但是不可用于高清 (HD) 电视信号。SCART 连接混合视频和音频信号。

请使用 SCART 适配线缆连接设备。



## 音频输出 - 光纤

“音频输出 -

光纤”是高质量的声音连接。此光纤连接可承载 5.1 音频通道。如果您的设备（通常是家庭影院系统 (HTS)）没有 HDMI ARC 接口，可使用此接口连接 HTS 上的“音频输入 - 光纤”接口。“音频输出 - 光纤”接口将声音从电视发送到 HTS。

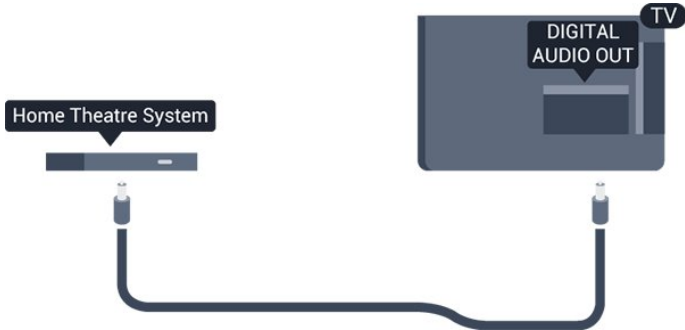

您可以设置音频输出信号的类型，以适合家庭影院系统的音频功能。

如果声音与屏幕上的视频不匹配，可以调整音频与视频同步。

3.2

## EasyLink HDMI CEC

### EasyLink

有了 EasyLink，就可使用电视遥控器操作连接的设备。EasyLink 使用 HDMI CEC（消费电子控制）来与连接的设备通信。设备必须支持 HDMI CEC，并且必须连接到 HDMI 接口。



### EasyLink 设置

EasyLink 在电视出厂时已启用。请确保所有 HDMI CEC 设置在连接的 EasyLink 设备上都已设置正确。EasyLink 可能不与其他品牌的设备兼容。

### 其他品牌的 HDMI CEC



不同品牌的 HDMI CEC 功能有不同的名称。例如：Anynet、Aquos Link、Bravia Theatre Sync、Kuro Link、Simplink 和 Viera Link。并非所有品牌都与 EasyLink 完全兼容。

示例 HDMI CEC 品牌名称是其各自所有者的财产。

## 操作设备

要操作连接到 HDMI 并设置了 EasyLink 的设备，请在电视接口列表中选择该设备或其活动。按  SOURCES，选择连接至 HDMI 接口的设备，然后按 OK。



选定设备后，电视遥控器即可控制该设备。但是  和  OPTIONS 键以及某些其他电视键不会转到该设备。如果电视遥控器上没有需要的键，可以选择“选项”菜单中的键。

按

 OPTIONS

，然后选择菜单栏中的控件

。在屏幕上，选择您需要的设备键，然后按 OK。某些专用的设备键可能不在“控件”菜单上出现。



注意：只有支持 EasyLink 遥控功能的设备才会响应电视遥控器。

## EasyLink 设置

EasyLink 设置在电视出厂时已启用。您可以单独关闭任何 EasyLink 设置。

### EasyLink

要完全关闭 EasyLink...

1. 按  并选择设置，然后按 OK。
2. 选择电视设置 > 一般设置 > EasyLink。
3. 选择 EasyLink。
4. 选择关闭，然后按 OK。
5. 按 （如有必要，请反复按）关闭菜单。

### EasyLink 遥控器

如果希望设备与电视遥控器通信，但又不想用电视遥控器操作设备，那么可以单独关闭 EasyLink 遥控器。您可以用电视遥控器控制多个 HDMI-CEC 兼容设备。

在 EasyLink 设置菜单中，选择 EasyLink 遥控器，然后选择关闭。

### 单键式播放

播放 HDMI-CEC 兼容设备时，电视将从待机模式下打开，并切换至正确的来源。

### 单键式待机

按下电视遥控器上的  时，电视和所有 HDMI-CEC 兼容设备均将切换至待机模式。

#### 系统音频控制

如果通过 HDMI ARC 接口连接包括扬声器在内的 HDMI-CEC 兼容设备，您可以选择通过这些扬声器而非电视扬声器收听电视音频。

### 3.3

## 通用接口 - CAM

### CI+

本电视可以处理 CI+ 条件接收。

通过 CI+，可以观看当地数字电视广播商提供的优质高清节目，如电影和体育比赛。这些节目由电视广播商加密，需要用预付费的 CI+ 模块解密。

在您向数字电视广播商订阅其优质节目时，它们会提供这个 CI+ 模块（条件接收模块 - CAM）。这些节目有高级复制保护。

请联系数字电视广播商，了解有关条款与条件的更多信息。



## CAM

### 插入 CAM 模块

插入 CAM 之前，请先关闭电视。

查看正确插入 CAM 的方法。不正确地插入可能损坏 CAM 和电视。

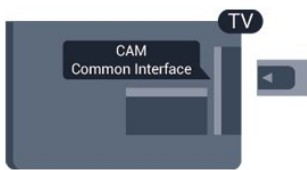

使用电视上的通用接口槽插入 CAM 卡。

将卡的正面面向您，然后尽量深地轻轻插入 CAM。

请将卡永久留在插槽中。

CAM 可能需要几分钟时间才能激活。移除 CAM

将会停用电视上的广播服务。

如果 CAM 已插入且订费已付（连接方法可能各不相同），那么您就可以观看电视广播。插入的 CAM 由电视机独占使用。

### 3.4

## 机顶盒 - STB

使用 2 根天线电缆将天线分别连接至机顶盒（数字接收器）和电视。

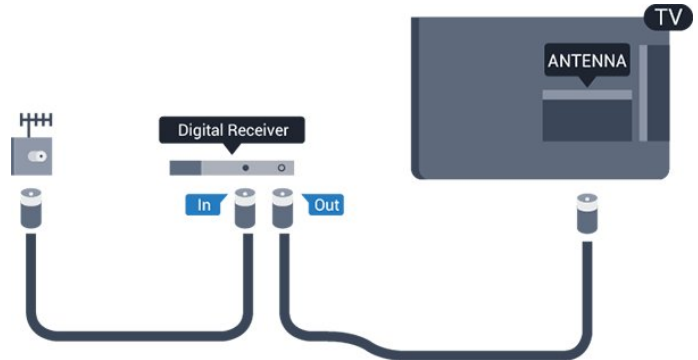

在天线连接的旁边，增加一根 HDMI 电缆将机顶盒连接到电视。

或者，如果机顶盒没有 HDMI 接口，可以使用 SCART 电缆。

### 自动关熄

如果只使用机顶盒的遥控器，则可关闭此自动定时器。这样做是为了防止电视在 4

小时（不按电视遥控器上的键）后自动关闭。

要关闭“关闭定时器”，请按 ，然后选择设置，再按 OK。

选择电视设置 > 一般设置 > 自动关闭

，再将滑动条设置到关闭。

### 3.5

## 卫星接收器

- 仅限于具有内置卫星调谐器的电视。

将圆盘式天线电缆连接到卫星接收器。

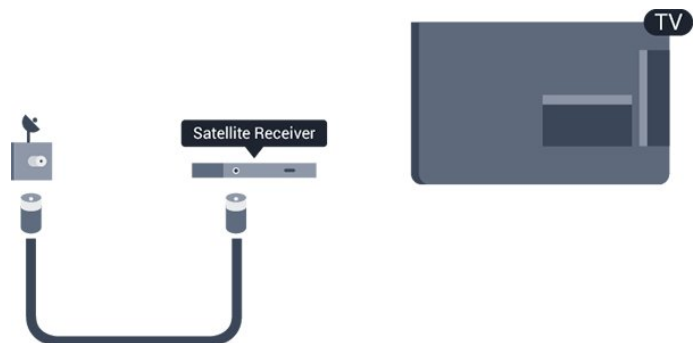

在天线连接的旁边，增加一根 HDMI 电缆将设备连接到电视。

或者，如果设备没有 HDMI 接口，可以使用 SCART 电缆。



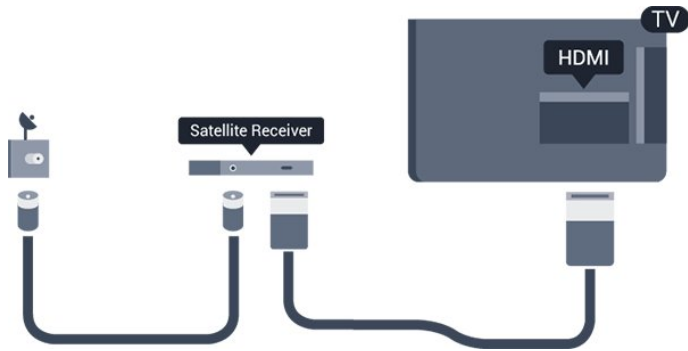

### 自动关熄

如果只使用机顶盒的遥控器，则可关闭此自动定时器。这样做是为了防止电视在 4 小时（不按电视遥控器上的键）后自动关闭。

要关闭“关闭定时器”，请按 **▲**，然后选择设置，再按 OK。选择电视设置 > 一般设置 > 自动关闭，再将滑动条设置到关闭。

### 3.6

## 家庭影院系统 - HTS

### 连接 HTS

使用 HDMI 电缆将家庭影院系统 (HTS) 连接到电视。可以将飞利浦平板影院或 HTS 与内置光盘播放机相连。

或者，如果设备没有 HDMI 接口，可以使用 SCART 电缆。

### HDMI ARC

如果家庭影院系统有 HDMI ARC 接口，那么可使用电视上的任一 HDMI 接口进行连接。有了 HDMI ARC，就无需再连接额外的音频电缆。HDMI ARC 连接已混合这两种信号。电视上的所有 HDMI 接口都能提供音频回传通道 (ARC) 信号。但在连接家庭影院系统后，电视只能将 ARC 信号发送到此 HDMI 接口。

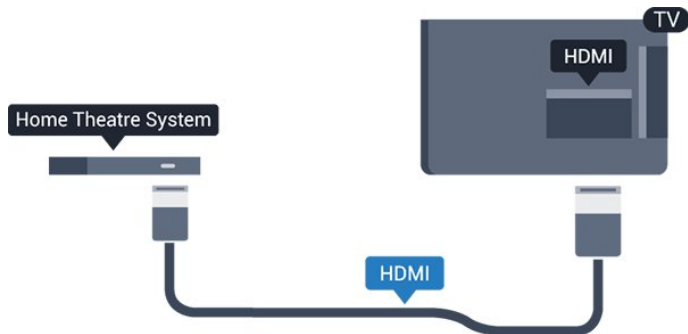

如果家庭影院系统没有 HDMI ARC 连接，请添加一根光纤音频线缆 (Toslink)，将电视图像的声音发送到家庭影院系统。

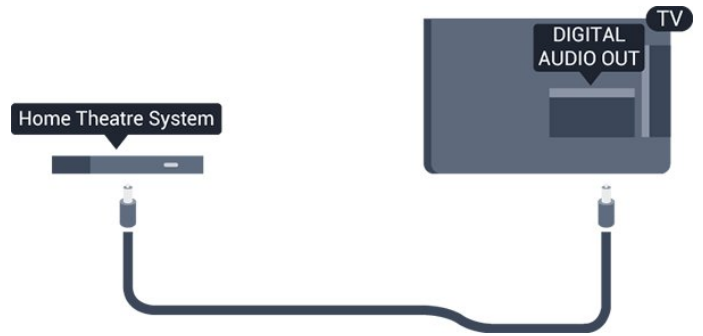

### 音频与视频同步 (同步)

如果声音与屏幕上的视频不匹配，那么可以在大多数带光盘播放机的家庭影院系统上设置延迟，以使声音与视频匹配。

## 音频输出设置

### 音频输出延迟

在家庭影院系统 (HTS) 连接到电视时，电视上的画面与 HTS 的声音应同步。

### 音频与视频自动同步

在最新的飞利浦家庭影院系统上，音频与视频总是自动同步，并始终正确。

### 音频同步延迟

在某些家庭影院系统上，可能需要调整音频同步延迟，以使音频与视频同步。在 HTS 上，提高延迟值，直至图像与声音匹配。可能需要 180 毫秒的延迟值。请阅读 HTS 的用户手册。在 HTS 上设置好延迟值后，需要关闭电视上的音频输出延迟。

要关闭“音频输出延迟”...

1. 按 **▲** 并选择设置，然后按 OK。
2. 选择电视设置 > 声音 > 高级 > 音频输出延迟。
3. 选择关闭，然后按 OK。
4. 按 **↩** (如有必要，请反复按) 关闭菜单。

### 音频输出修正

如果在家庭影院系统上无法设置延迟，可以设置电视来同步声音。可以设置一个修正值来补偿家庭影院系统处理电视画面的声音所需的时间。可以 1 毫秒为步长设置修正值。最大设置为 12 毫秒。音频输出延迟设置应开启。

要在电视上同步声音...

1. 按 **▲** 并选择设置，然后按 OK。
2. 选择电视设置 > 声音 > 高级 > 音频输出修正。
3. 使用滑动条设置声音修正值，然后按 OK。
4. 按 **↩** (如有必要，请反复按) 关闭菜单。

## 音频输出格式

如果家庭影院系统 (HTS) 有 Dolby Digital 或 DTS® 之类的多声道声音处理功能，那么可将音频输出格式设置为“多声道”。利用多声道，电视可将压缩的多声道声音信号从电视频道或连接的播放机发送到家庭影院系统。如果家庭影院系统没有多声道声音处理功能，则选择“立体声”。

要设置“音频输出格式”...

1. 按 **▲** 并选择设置，然后按 OK。
2. 选择电视设置 > 声音 > 高级 > 音频输出格式。
3. 选择多声道或立体声。
4. 按 **↵** (如有必要，请反复按) 关闭菜单。

## 音频输出调衡

在电视和家庭影院系统之间来回切换时，可使用音频输出调衡设置来调衡两者的音量 (响度)。音量差异可能由声音处理的差异所引起。

要调衡音量差异...

1. 按 **▲** 并选择设置，然后按 OK。
2. 选择电视设置 > 声音 > 高级 > 音频输出调衡。
- 3.

如果音量差异较大，选择更多

。如果音量差异较小，则选择更少。

按 **↵** (如有必要，请反复按) 关闭菜单。

音频输出调衡同时影响“音频输出 - 光纤”和 HDMI ARC 声音信号。

## HTS 声音问题

### 噪音较大

如果您从已插入的 USB 闪存盘或所连接的电脑观看视频，则家庭影院系统的声音可能失真。

1. 按 **▲** 并选择设置，然后按 OK。
2. 选择电视设置 > 声音 > 高级 > 音频输出格式。

### 无声音

如果在家庭影院系统的电视上听不到声音，请检查以下事项...

- 检查是否已将 HDMI

线缆连接至家庭影院系统上的 HDMI

ARC 接口。电视上的所有 HDMI 接口均为 HDMI ARC 接口。

- 检查电视上的 HDMI ARC 设置是否已开启。

转到 **▲** > 设置 > 电视设置 > 声音 > 高级 > HDMI 1

-ARC。

## 3.7

# 蓝光光盘播放机

使用高速 HDMI 电缆将蓝光光盘播放机连接至电视。

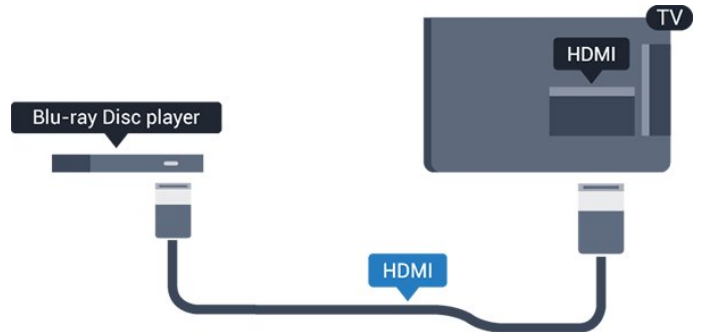

如果蓝光光盘播放机有 EasyLink HDMI CEC，就可以用电视遥控器操作播放机。

## 3.8

# DVD 播放机

使用 HDMI 电缆将 DVD 播放机连接至电视。

或者，如果设备没有 HDMI 接口，可以使用 SCART 电缆。

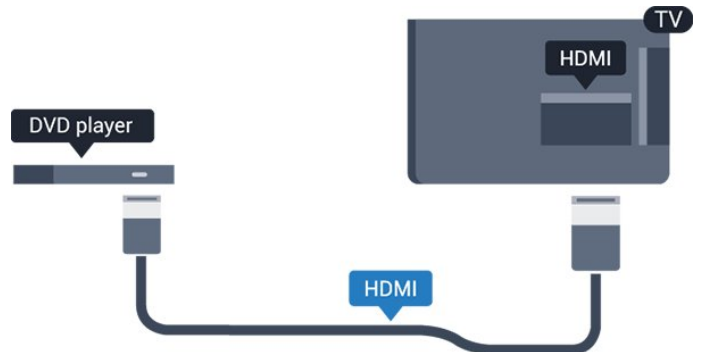

如果 DVD 播放机连接了 HDMI，并且有 EasyLink CEC，那么就可以用电视遥控器操作播放机。

## 3.9

# 游戏控制台

## HDMI

为获得最佳质量，请用高速 HDMI 电缆将游戏机连接到电视



## 视频-音频 LR / Scart

用分量电缆 (CVBS) 和音频 L/R 电缆将游戏机连接到电视。

如果游戏机只有视频 (CVBS) 和音频 L/R 输出，请使用视频音频 L/R 至 SCART 适配器连接到 SCART 接口。

注意：电视中未随附 CVBS 至 Scart 适配器。

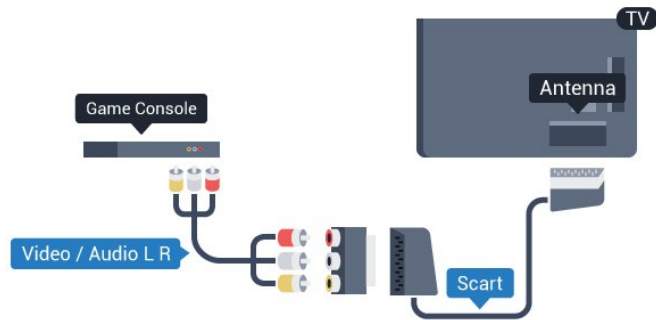

3.10

## USB 硬盘驱动器

### 您需要执行的操作

如果连接了 USB 硬盘驱动器，则可以暂停或录制电视广播。电视广播必须是数字广播 (DVB 广播之类)。

#### 暂停

要暂停节目，需要有至少 32GB 磁盘空间的 USB 2.0 兼容硬盘驱动器。

#### 录制

要暂停和录制广播，需要至少 250GB 的磁盘空间。



### 电视指南

在决定购买录制用的 USB 硬盘驱动器之前，请先检查能否在您的国家/地区录制数字电视频道。

按遥控器上的  TV

GUIDE

。如果电视指南页上有“录制”按钮，那么说明可以录制。

## 安装

必须先连接和格式化 USB 硬盘驱动器，才可以暂停或录制广播。

1. 将 USB 硬盘驱动器连接到电视上的某个 USB 接口。格式化时，不要将另一个 USB 设备连接到其他 USB 端口。



2. 打开 USB 硬盘驱动器和电视。

3. 将电视调谐至数字电视频道时，按  (暂停)。尝试暂停将启动格式化。

按照屏幕上的说明操作。

在 USB 硬盘驱动器格式化时，使其保持永久连接。

### 警告

USB 硬盘驱动器专为此电视而格式化，不可在其他电视或 PC 上使用存储的录音或录像。不要用任何 PC 应用程序复制或更改 USB 硬盘驱动器上录制的文件。这将损坏录制的内容。在格式化另一个 USB 硬盘驱动器时，前者的内容将丢失。安装在电视上的 USB 硬盘驱动器需要重新格式化才能用于计算机。

## USB 闪存盘

可以查看连接的 USB 闪存驱动器中的照片，或者播放其中的音乐和视频。

在电视打开时，将 USB 闪存驱动器插入电视上的某个 USB 接口。



电视检测到闪存驱动器，并打开显示其内容的列表。如果内容列表未自动显示，请按 **SOURCE**，选择 USB，然后按 OK。

要停止观看 USB 闪存盘的内容，请按 **EXIT** 或选择另一项活动。要断开 USB 闪存驱动器，可以随时拔出闪存驱动器。

## 摄像机

### HDMI

为获得最佳质量，请使用 HDMI 电缆将摄像机连接至电视。

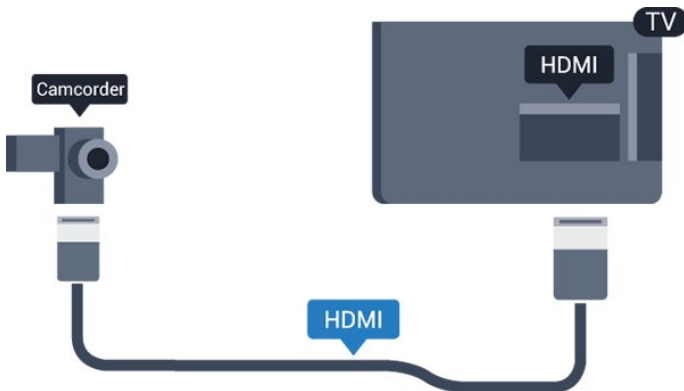

## 视频-音频 LR / Scart

可以使用 HDMI、YPbPr 或 SCART 接口连接摄像机。如果摄像机只有视频 (CVBS) 和音频 L/R 输出，请使用视频音频 L/R 至 SCART 适配器连接到 SCART 接口。

注意：电视中未随附 CVBS 至 Scart 适配器。

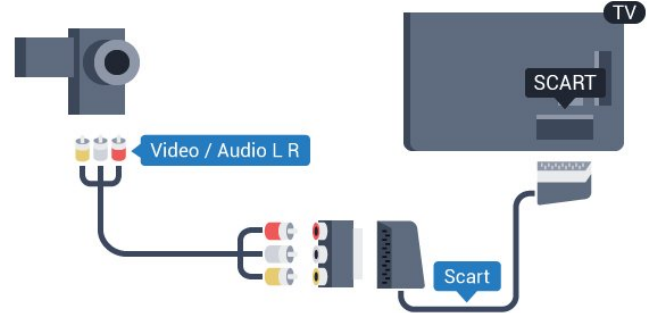

## 电脑

### 连接

可以将计算机连接到电视，并将电视用作 PC 显示器。

使用 HDMI

使用 HDMI 电缆将计算机连接到电视。

使用 DVI 至 HDMI

或者，可以使用 DVI 至 HDMI 适配器将 PC 连接至电视背面的 HDMI，将音频 L/R 电缆 (3.5 毫米迷你插孔) 连接到电视机背面的 AUDIO IN L/R。

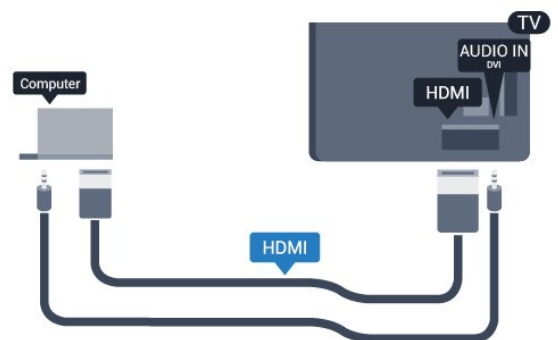

---

## 设置

### 理想显示器设置

如果计算机在“来源”菜单（接口列表）中作为“计算机”类型的设备添加，则电视自动设置为理想的计算机设置。

如果您使用计算机观看影片，或将其用来玩游戏，那么可能要将电视重新设置为理想的电视观看或游戏设置。

要手动将电视设置为理想设置...

1. 按 **⬆** 并选择设置，然后按 OK。
2. 选择电视设置 > 画面 > 高级 > 游戏或电脑，然后按 OK。
3. 选择游戏（适用于游戏）或选择电脑（适用于观看影片），然后按 OK。
4. 按 **⬅**（如有必要，请反复按）关闭菜单。

停

止玩

游戏后，请记得将游戏设置或电脑设置重新设为电脑。

---

### 3.14

## 耳机

可以将一副耳机连接到电视机上的  接口。此接口是 3.5 毫米迷你插孔接口。耳机的音量可单独调节。

要调节音量...

1. 按 **⬆** 并选择设置，然后按 OK。
2. 选择电视设置 > 声音 > 耳机音量，然后按 OK。
3. 按 **▲**（向上）或 **▼**（向下）调节音量。
4. 按 **⬅**（如有必要，请反复按）关闭菜单。



---

# 打开

---

## 4.1

### 开机或待机

打开电视之前，请确保插入电视背面的主电源。  
如果红色指示灯熄灭，请按电视侧面的电源按钮，使电视进入待机状态 - 红色指示灯将亮起。



在电视处于待机状态时，按遥控器上的  开启电视。



#### 切换至待机模式

要将电视切换为待机模式，请按遥控器上的 。

#### 关闭

要关闭电视，请按电视侧面的电源按钮。红色指示灯熄灭。  
电视仍然连接到主电源，但是耗能最少。

要完全关闭电视，请拔下电源插头。

断开电源插头时，请总是拔出电源插头，切勿拉扯电源线。  
请确保您始终可以完全接触到电源插头、电源线和电源插座。

# 遥控器

## 5.1

### 键概述

#### 顶部



#### 1. 待机/开

打开电视或返回待机模式。

#### 2. 播放 键

- 播放 ►, 开始播放。
- 暂停 ||, 暂停播放
- 停止 ■, 停止播放
- 倒回 ◀◀, 倒回
- 快进 ▶▶, 向前快进
- 录制 ●, 立即录制

#### 3. TV GUIDE

打开或关闭电视指南。

#### 4. SETUP

打开“设置”菜单。

#### 5. FORMAT

打开或关闭“画面格式”菜单。

#### 中期



#### 1. SOURCES

打开或关闭“来源”菜单 - 即连接的设备列表。

#### 2. 彩色键

屏幕上的说明介绍了按钮功能。

#### 3. INFO

打开或关闭节目信息。

#### 4. BACK

切换回您选择的上一个频道。

关闭菜单而不更改设置。

#### 5. HOME

打开或关闭主菜单。

#### 6. TV EXIT

返回观看电视。

#### 7. OPTIONS

打开或关闭“选项”菜单。

#### 8. OK 键

确认选择或设置。

#### 9. 箭头 / 导航键

向上、向下、向左或向右导航。

#### 10. LIST

打开或关闭频道列表。

#### 底部



#### 1. 音量

调节音量。

#### 2. 数字键和文本键盘

直接选择电视频道或输入文本。

#### 3. SUBTITLE

打开字幕、关闭字幕或自动。

#### 4. 频道

切换到频道列表中的下一个频道或上一个频道、打开文本中的下一页或上一页，或者启动光盘的下一章或上一章。

#### 5. 静音

静音或恢复声音。

#### 6. TEXT

打开或关闭文本/图文电视。

## 5.2

### 红外传感器

电视可从使用 IR ( 红外线 ) 发送命令的遥控器接收命令。如果使用此类遥控器，请总是确保将遥控器对准电视正面的红外传感器。

## 电池

1. 按箭头所示的方向滑动电池仓门。
2. 将旧电池换成 2 节 AAA-LR03-1.5V 型电池。请确保电池的 + 和 - 端正确对齐。
3. 重新放回电池仓门。
4. 将其向后滑，直至卡到位。

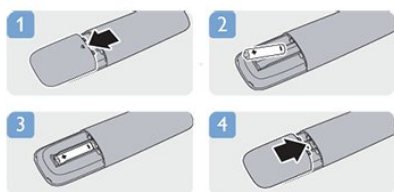

如果长时间不使用遥控器，请将电池取出。  
请根据使用终止指令安全处置旧电池。

## 清洁

您的遥控器已经用防刮擦涂层处理。

要清洁遥控器，请使用柔软的湿布。切勿使用酒精、化学品或家用清洁剂等物质清洁遥控器。



# 电视频道

## 6.1

### 观看电视频道

#### 切换频道

要观看电视频道，请按 **TV**

。电视将调到您上次观看的电视频道。

或者，按 **HOME** 打开主菜单，然后选择电视，再按 **OK**。

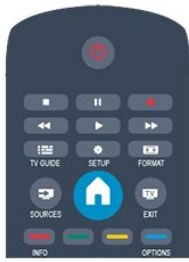

要切换频道，请按 **CH+**

或 **CH-**。如果您知道频道编号，请用数字键键入编号。

在输入编号以切换频道后，按 **OK**。

要切换回上次调到的频道，请按 **RECALL**。

从频道列表切换频道

观看电视频道时，按 **LIST** 打开频道列表。



频道列表可能有多个频道页。要查看下一页或上一页，请按 **CH+** 或 **CH-**。

要关闭频道列表而不切换频道，请再次按 **LIST**。

#### 无线电频道

如果能获得数字广播，那么数字无线电台会在设定期间进行设定。切换无线电频道与切换电视频道一样。

## 频道列表

查看所有频道列表

1. 观看电视频道时，按 **LIST** 打开频道列表。
2. 按 **OPTIONS** 打开“选项”菜单。
3. 选择列表，然后您可以选择全部、收藏频道、无线电和新频道。

#### 收藏频道

可以创建收藏频道列表，其中只有您想观看的频道。选中收藏频道列表后，您在频道间切换时将只看到您收藏的频道。

#### 创建收藏频道列表

1. 观看电视频道时，按 **LIST** 打开频道列表。
2. 选择要标记为收藏频道的频道，然后按 **OPTIONS**。
3. 选择添加收藏频道，然后按 **OK**。选定的频道将标有 **★**。
4. 要结束操作，请按 **BACK**。频道会添加到收藏频道列表。
5. 要从收藏频道列表中删除频道，请选择带有 **★** 的频道，然后按 **OPTIONS**，选择删除收藏频道，然后按 **OK**。

#### 重排

可以重新排序（重新定位）收藏频道列表中的频道。

1. 在频道列表收藏频道中，突出显示您要重新定位的频道。
2. 按 **OPTIONS**。
3. 选择重新排序，然后按 **OK**。
4. 选择要重新排序的频道，然后按 **OK**。
5. 按导航按钮将突出显示的频道移到另一个位置，然后按 **OK**。
6. 完成后，请按 **OPTIONS**。
7. 选择退出重新排序，然后按 **OK**。

您可以突出显示其他频道并执行同样的操作。

#### 在其他频道列表中添加或删除收藏的频道

可以从全部、无线电和全新频道列表中将频道和无线电台标记为收藏频道。在这些列表中，突出显示您要添加到收藏频道列表中的频道，然后按 **OPTIONS**。选择添加收藏频道，然后按 **OK**。

选定的频道将标有 **★**。

要从收藏频道列表

中删除频道，请选择删除收藏频道，然后按 **OK**。

#### 重命名频道

您可以重命名频道列表中的频道。

1. 在某个频道列表中选择要重命名的频道。

2. 按 **≡** OPTIONS。
3. 选择重命名，然后按 OK。

## 锁定频道

为了防止儿童观看某个频道或节目，可以锁定频道或锁定年龄分级节目。

### 锁定频道

您可以锁定频道，以防儿童观看。如要观看锁定的频道，需要输入儿童锁密码。不可锁定连接的设备上的节目。

#### 要锁定频道...

1. 观看电视频道时，按 **≡** LIST 打开频道列表。
2. 在任何列表中，选择您要锁定的频道。
3. 按 **≡** OPTIONS，然后选择锁定频道。  
在频道列表中，锁定的频道标有锁标记 **🔒**。

#### 要解锁

频道，请在频

道列表中选择锁定的频道，

按 **≡** OPTIONS，然后选择解锁频道

。您需要输入儿童锁密码。

## 家长评级

为了防止儿童观看不适合其年龄的节目，可以使用年龄分级。

某些数字电视台的节目有年龄分级。当某个节目的年龄分级等于或高于您设置为儿童年龄分级的年龄时，该节目将锁定。

要观看锁定的节目，必须输入儿童锁密码。所有频道都设置了家长年龄分级。

#### 要设置年龄分级...

1. 按 **⬆** 并选择设置，然后按 OK。
2. 选择频道设置 > 儿童锁 > 父母分级，然后按 OK。
3. 输入 4 位儿童锁密码。输入 4 位儿童锁密码，然后确认。现在即可设置年龄分级。
4. 设置年龄，然后按 OK。
5. 按 **↩** (如有必要，请反复按) 关闭菜单。
6. 要关闭家长年龄分级，选择无作为年龄设置。

电视会要求提供密码来解锁节目。对于某些广播商/运营商，电视只会锁定拥有较高分级的节目。

## 设置或更改锁密码

### 要设置锁密码或更改当前密码...

1. 按 **⬆** 并选择设置，然后按 OK。
2. 选择频道设置 > 儿童锁 > 更改密码，然后按 OK。
3. 如果已经设置密码，请输入当前儿童锁密码，然后输入新密码两次。

新密码随即设置。

忘记了密码？

要在

忘记密码时覆盖并输入新的儿童锁密码，请输入 8888。

## 画面格式

如果黑条出现在画面顶部和底部，或者两边都有，那么可将画面格式调整为充满屏幕的格式。

### 要更改画面格式...

1. 观看电视频道时，按 **⏏** 打开画面格式菜单。
2. 从列表中选择一种格式，然后按 OK。

根据屏幕上的画面，以下格式可选...

- 自动

根据输入源调整画面格式。

- 超级缩放

消除 4:3 广播节目侧边的黑条。画面调整到适合屏幕。

- 电影扩展 16:9

将 4:3 格式调整为 16:9。不推荐用于 HD 或 PC。

- 宽屏幕

将画面拉伸到 16:9 格式。

- 无格式转换

HD 或 PC 输入的专家模式。逐像素显示。来自计算机的画面可能出现黑条。

- 4:3

显示经典的 4:3 格式。

## 文本/图文电视

### 文本页面

要在观看电视频道时打开文本 (图文电视)，请按 TEXT。

要关闭文本，再次按 TEXT。



### 选择文本页面

#### 要选择页面...

1. 使用数字键输入页号。
2. 使用箭头键导航。
3. 按彩色键选择屏幕底部的彩色编码项。

### 文本子页面

一个文本页号可容纳多个子页。子页号显示在主页号旁边的横条中。

要选择子页，请按 **◀** 或 **▶**。

### T.O.P. 文本页

某些广播商提供 T.O.P. 文本。

要在文本中打开 T.O.P. 文本页，按 **≡** OPTIONS，然后选择 T.O.P. 概述。

## 收藏页面

电视会生成您打开的最后 10 个文本页的列表。可以在收藏文本页栏中轻松重新打开它们。

1. 在文本中，选择屏幕左上角的星标以显示收藏页栏。
2. 按 **▼** (向下) 或 **▲** (向上) 选择页号，然后按 OK 打开页面。

可以用清除收藏页面选项清除此列表。

## 搜索文本

您可以选择一个单词，然后扫描文本来寻找出现该单词的所有位置。

1. 打开文本页，然后按 OK。
2. 用箭头键选中一个单词或数字。
3. 再次按 OK 直接跳转到下一个出现该单词或数字的地方。
4. 再次按 OK 跳转到后续出现该单词或数字的地方。
5. 要停止搜索，请按 **▲** (向上) 直至没有选中任何内容。

## 来自连接设备的文本

某些接收电视频道的设备也可提供文本。  
要从连接的设备打开文本...

1. 按 **▲**，选择设备，然后按 OK。
2. 在观看设备上的频道时，按 **≡** OPTIONS，选择显示设备键，然后选择 **≡** 键，最后按 OK。
3. 按 **↵** 隐藏设备键。
4. 要关闭文本，再次按 **↵**。

## 数字文本 (仅限于英国)

一些数字广播商在他们的数字电视频道上提供专用的数字文本或互动电视。这些服务包括使用数字键、彩色键和箭头键进行选择 and 导航的普通文本。

要关闭数字文本，按 **↵**。

---

## 文本选项

在文本中，按 **≡** OPTIONS 选择以下选项...

- 冻结页面 / 取消冻结页面  
停止子页自动滚动。
- 双视窗/全屏幕  
并排显示电视频道和文本。
- T.O.P. 概述  
打开 T.O.P. 文本。
- 放大 / 正常视图  
放大文本页，以便舒适地阅读。
- 显示  
显示隐藏的页面信息。
- 循环子页面  
有子页面时，循环子页面。

## - 语言

切换文本用来正确显示内容的字符组。

## - 图文电视 2.5

激活图文电视 2.5，以获得更多色彩和质量更好的图形。

---

## 文本设置

### 文本语言

某些数字广播商提供了多种文本语言。  
要设置主要和辅助文本语言...

1. 按 **▲** 并选择设置，然后按 OK。
2. 选择频道设置 > 语言。
3. 选择主图文电视或辅助图文电视。
4. 选择所需的文本语言。
5. 按 **↵** (如有必要，请反复按) 关闭菜单。

### 图文电视2.5

如果有图文电视 2.5 可用，那么可以获得更多色彩和更好的图形。图文电视 2.5 作为标准出厂设置激活。  
要关闭图文电视 2.5...

1. 按 TEXT。
2. 观看图文电视时，按 **≡** OPTIONS。
3. 选择图文电视 2.5 > 关闭。
4. 按 **↵** (如有必要，请反复按) 关闭菜单。

---

## 字幕和语言

### 字幕

#### 打开字幕

要打开“字幕”菜单，请按 SUBTITLE。  
您可以将字幕设置为关闭字幕、打开字幕或自动。  
要在播送的节目不是您所用的语言 (您为电视设置的语言) 时显示字幕，请选择自动。此外，此设置还将在您按 **🔇** 静音时显示字幕。  
对于模拟频道，必须在文本中启用字幕。



#### 数字频道的字幕

对于数字频道，无需在文本中设置字幕。  
数字频道可能为一个节目提供多种字幕语言。您可以设置自己喜欢的主字幕语言和次字幕语言。如果有这两种语言的字幕，电视会显示。  
如果没有提供首选字幕语言，则可选择提供的另一种字幕语言。

要设置主次字幕语言...

1. 按 **▲** 并选择设置，然后按 OK。
2. 选择频道设置，然后选择语言。
3. 选择主字幕语言或次字幕语言，然后按 OK。
4. 选择语言，然后按 OK。
5. 按 **↵** (如有必要，请反复按) 关闭菜单。

要在没有提供首选语言时选择其他字幕语言...

1. 按 **≡** OPTIONS。
2. 选择字幕语言，然后选择您暂时想要的语言，再按 OK。

模拟频道的字幕

对于模拟频道，需要手动为每个频道提供字幕。

1. 切换到某个频道，然后按 TEXT 打开文本。
2. 输入字幕的页号，通常是 888。
3. 再次按 TEXT 将文本关闭。

如果在观看此模拟频道时，在“字幕”菜单上选择“开启”，那么如果有字幕，字幕就会显示。

选项菜单上的状态。

---

音频语言

数字电视频道可能为一个节目播送多种口语的音频。您可以设置自己喜欢的主音频语言和次音频语言。如果有这两种语言的音频，电视会切换到此音频。如果没有提供首选音频语言，则可选择提供的另一门音频语言。

要设置主次音频语言...

1. 按 **▲** 并选择设置，然后按 OK。
2. 选择频道设置，然后选择语言。
3. 选择主字幕语言或次字幕语言，然后按 OK。
4. 选择语言，然后按 OK。
5. 按 **↵** (如有必要，请反复按) 关闭菜单。

要在没有提供首选音频语言时选择其他音频语言...

1. 按 **≡** OPTIONS。
2. 选择音频语言，然后选择您暂时想要的音频语言，再按 OK。

适合听觉和视觉障碍人士的音频语言

有些数字电视频道专为听障或视障人士播放特殊的音频和字幕。

---

菜单语言

要更改电视菜单和消息的语言...

1. 按 **▲** 并选择设置，然后按 OK。
2. 选择电视设置 > 一般设置 > 菜单语言，再按 OK。
3. 选择您所要的语言，然后按 OK。

4. 按 **↵** (如有必要，请反复按) 关闭菜单。

---

6.2

## 频道安装

---

### 更新频道

自动更新

如果接收到数字频道，可将电视设置为使用新频道自动更新列表。

或者，您可以自行开始频道更新。

自动频道更新

每天早上 6 点，电视都会更新频道和存储新频道。新频道不仅存储在所有频道列表中，还会存储在全新频道列表中。空频道会被删除。

如果发现了新频道或者有频道被更新或删除，电视启动时会显示消息。电视必须处于待机模式才可自动更新频道。

要关闭启动时显示的消息...

1. 按 **▲** 并选择设置，然后按 OK。
2. 选择频道设置，然后按 OK。
3. 选择频道设定 > 频道更新消息 > 关闭。

要关闭自动频道更新...

1. 按 **▲** 并选择设置，然后按 OK。
2. 选择频道设置，然后按 OK。
3. 选择频道设定 > 自动频道更新 > 关闭。

开始更新

要自行开始更新...

1. 按 **▲** 并选择设置，然后按 OK。
2. 选择搜索频道，然后按 OK。
- 3.

选择更新频道

，并按照屏幕上的说明操作。更新可能需要几分钟时间。

在某些国家/地区，自动频道更新可在观看电视的同时或者电视处于待机模式下的任何时刻完成。

---

新频道

通过自动频道更新添加的新频道可在全新频道列表

中轻松找到。相同

的新频道还会存储在全部或无线电频道列表中。

只要您不将新频道标记为收藏频道或调谐至它们，那么新频道就会保存在全新频道列表中。

---

## 重新安装频道

您可以搜索和重新设定频道，并让所有其他电视设置保持不变。或者，您还可以进行全新的电视设定。

如果设置了儿童锁密码，您需要输入此密码，然后才能重新设定频道。

### 重新安装频道

要仅重新设定频道...

1. 按 **▲** 并选择设置，然后按 OK。
2. 选择搜索频道 > 重新设定频道，然后按 OK。
3. 选择设定电视所在的国家/地区。
4. 选择天线 (DVB-T) 或有线 (DVB-C)。  
。频道搜索可能需要几分钟时间。请按照屏幕上的说明操作。

### 完全设定

要重新执行完全电视设定...

1. 按 **▲** 并选择设置，然后按 OK。
2. 选择电视设置 > 一般设置 > 重新设定电视机，然后按 OK。  
。设定可能需要几分钟时间。请按照屏幕上的说明操作。

### 工厂设定

出厂设置可将电视重新设置到原始的画面和声音电视设置。要切换回原始出厂设置...

1. 按 **▲** 并选择设置，然后按 OK。
2. 选择电视设置 > 一般设置 > 出厂设置，然后按 OK。
3. 按 OK 确认。
4. 按 **↩** (如有必要，请反复按) 关闭菜单。

---

## 复制频道列表

### 简介

复制频道列表适用于经销商和专业用户。在某些国家/地区，复制频道列表仅可用于复制卫星频道。

### 借助复制频道列表

功能，您可将一台电视上设定的频道复制到相同系列的另一台飞利浦电视上。借助复制频道列表功能，您还可通过将预定义频道列表上传到电视上来避免进行耗时的频道搜索。请使用至少 1 GB 的 USB 闪存盘。

### 条件

- 两台电视均属于同一年款系列。
- 两台电视拥有相同的硬件类型。请查看电视背面电视型号铭牌上注明的硬件类型。通常会标注为 Q... LA
- 两台电视拥有兼容的软件版本。

### 当前版本

您可通过 **▲** > 设置 > 软件设置中的当前软件信息查看电视软件的当前版本。

---

## 复制频道列表

要复制频道列表...

1. 打开已设定频道的电视。插入 USB 存储设备。
2. 按 **▲** 并选择设置，然后按 OK。
3. 选择电视设置 > 一般设置 > 复制频道列表 > 复制到 USB，然后按 OK。  
。要从此电视复制频道列表，系统可能会要求您输入您在设定过程中输入的儿童锁密码。
4. 复制完成后，请拔下 USB 存储设备。

现在，您可将已复制的频道列表上传到另一台飞利浦电视上。

---

## 上传频道列表

### 上传已复制的频道列表

根据电视是否已完成设定，您必须采用不同的方式来上传频道列表。

### 上传至尚未设定的电视

1. 插上电源插头开始设定，选择语言和国家/地区。可跳过搜索频道。完成设定。
2. 插入存有其他电视频道列表的 USB 存储设备。
3. 要开始上传频道列表，请按 **▲** 并选择设置，然后按 OK。
4. 选择电视设置 > 一般设置 > 复制频道列表 > 复制到电视，然后按 OK。系统可能会要求您输入此台电视的儿童锁密码。
5. 电视会通知您频道列表是否已成功复制到电视。请拔下 USB 存储设备。

### 上传至已设定的电视

1. 验证电视的国家/地区设置。(要验证此设置，请按 **▲** 并选择设置，然后按 OK。选择搜索频道 > 重新设定频道，然后按 OK。按 **↩** 之后再按取消退出搜索频道。) 如果国家/地区设置正确，请继续执行步骤 2。如果国家/地区设置不正确，您需要启动重新设定。要启动重新设定，请按 **▲** 并选择设置，然后按 OK。  
。请选择电视设置 > 一般设置 > 重新设定电视机 > OK。  
。选择正确的国家/地区并跳过搜索频道。然后完成设定。完成后，请继续执行步骤 2。
2. 插入存有其他电视频道列表的 USB 存储设备。
3. 要开始上传频道列表，请按 **▲** 并选择设置，然后按 OK。
4. 选择电视设置 > 一般设置 > 复制频道列表 > 复制到电视，然后按 OK。系统可能会要求您输入此台电视的儿童锁密码。
5. 电视会通知您频道列表是否已成功复制到电视。请拔下 USB 存储设备。

---

## DVB-T 或 DVB-C

---

### DVB-T 或 DVB-C 接收

如果您所在国家/地区允许 DVB-T 和 DVB-C 接收，且此电视已准备好接收您所在国家/地区的 DVB-T 和 DVB-C，则您已在频道设定过程中选择二者之一。

如希望更改 DVB 设置以开始新频道设定...

1. 按 **▲** 并选择设置，然后按 OK。
2. 选择频道设置，然后按 OK。
3. 选择频道设定 > 天线接口 > 天线 (DVB-T) 或有线 (DVB-C)，然后按 OK。
4. 选择所需的 DVB 设置。
5. 按 **↩** (如有必要，请反复按) 关闭菜单。

### DVB-C 频道设定

为了便于使用，所有 DVB-C 设置均设为自动。如果您的 DVB-C 提供商提供了具体的 DVB-C 值、网络 ID 或网络频率，在设定过程中，当电视要求上述信息时请输入这些值。

在设定过程中，可能有必要调整扫描 (全面或快速扫描) 或在设置菜单中输入特定符号率。

要设置符号率，请先将符号率设置为手动。

### 频道编号冲突

在某些国家/地区，不同的电视频道 (广播商) 可能拥有相同的频道编号。设定时，电视会在显示列表的同时显示频道编号冲突。您需要选择在拥有多个电视频道的频道编号上设定哪个电视频道。

### DVB-T + DVB-C

如果您可以同时使用 DVB-T 天线输入和 DVB-C 输入，您可将电视设置为同时支持 DVB-T 和 DVB-C。请先设定一个系统，然后再设定另一个系统，并进行必要的设置。

设定好每个系统

后，您需要在电视背面的天线

接口上切换天线输入信号，并在相应的系统中设置电视以查看电视上设定的频道。

要选择 DVB-T 或 DVB-C 设置，请见上文。

---

## DVB 设置

---

### 访问 DVB 设置

1. 按 **▲** 并选择设置，然后按 OK。
2. 选择搜索频道，然后按 OK。
3. 选择重新设定频道。
4. 选择设定电视所在的国家/地区。
5. 选择有线 (DVB-C)。
6. 选择开始搜索频道，或选择 DVB-C 设置。
7. 按 **↩** (如有必要，请反复按) 关闭菜单。

---

## 符号率模式

如

果您

的有线提

供商没有提供用于

设定电视频道的具体符号率值，请将符号率模式设置保持为自动。

如果您获得了具体

的符号率值，请选择手动

。但是，您获得的值可能已存在于预定义符号率列表中。

请选择预定义符号率查看您是否已自动获得符号率值。

---

## 符号率

当符号率模式设置为手动

时，您可输入从有线提供商处获得的符号率值。要输入该值，请使用数字键。

---

## 网络频率

当频率扫描设置为快速或高级

时，您可在此输入从有线提供商处获得的网络频率值。要输入该值，请使用数字键。

---

## 频率扫描

选择搜索频道

的方法。您可以选择更迅速

的快速

扫描方法并使用您所在国家/地区大多数有线提供商所使用的预定义设置。

如果这样做会导致未设定频道或者某些频道缺失，您可以选择更广泛的完全

扫描方法。此方法需要更多的时间来搜索和设定频道。

---

## 网络 ID

当频率扫描设置为快速

时，您可在此输入从有线提供商处获得的网络 ID。要输入该值，请使用数字键。

---

## 数字频道

如果知道有线提供商不提供数字频道，您可以跳过搜索数字频道。选择关闭。

---

## 模拟声道

如果知道有线提供商不提供模拟频道，您可以跳过搜索模拟频道。选择关闭。

---

## 免费/加密

如果订阅了付费电视服务并拥有付费电视服务的 CAM - 条件接收功能模块，请选择免费 +

加密

。如果没

有订阅付费电视频道或服务，可以选择仅免费频道。

---

## 手动安装

可以逐个频道手动设定模拟电视频道。

要手动设定模拟频道...

1. 按 **▲** 并选择设置，然后按 OK。

2. 选择频道设置 > 频道设定 > 模拟：手动设定，然后按

OK。

- 系统

要设置电视系统，请选择系统，然后按 OK。

请选择您目前所在的国家或地区。

- 搜索频道

要查找频道，请选择搜索频道，然后按 OK。选择

搜索，然后按

OK

搜索。如希望存储该频道，请选择完成，然后按 OK。

- 微调

要微调频道，请选择微调，然后按 OK。您可以使用 **▲** 或

**▼** 微调频道。

如果希望存储找到的频道，请选择完成，然后按 OK。

- 存储

您可将该频道存储在当前频道编号上或存储为新频道编号

。

请选择储存当前频道或存储为新频道。

您可以重复这些步骤，直至找到所有可用的模拟电视频道

。



# 电视指南

## 7.1

### 使用电视指南

#### 您需要执行的操作

通过电视指南，您可查看自己频道当前和已排定的电视节目列表。根据电视指南信息（数据）的来源，会显示模拟和数字频道或者只显示数字频道。并非所有的频道都提供电视指南信息。

这款电视可收集安装于其上的频道的电视指南信息（例如使用观看电视功能收看到的频道）。这款电视无法收集从数字接收器观看的频道的电视指南信息。

#### 打开电视指南

要打开电视指南，请按  TV GUIDE。

再次按  TV GUIDE 将其关闭。

首次打开电视指南时，这款电视会扫描所有电视频道以获取节目信息。这可能需要几分钟时间。电视指南数据会存储在电视中。

#### 调谐到某个节目

切换到某个节目

您可从电视指南切换至当前的节目。

要选择节目，请使用箭头键突出显示节目名称。

导航到右侧，以查看当天晚些时候已排定的节目。

要切换到该节目（频道），请选择该节目，然后按 OK。

查看节目详情

要调用所选节目的详细信息，请按  INFO。

#### 更改日期

电视指南可显示接下来几天（最多 8 天）已排定的节目。

如果电视指南信息来自广播商，按  +

可选择未来

几天中的一天并查看其

节目表。按  - 则可返回至前一天。

此外，您还可以按  OPTIONS，然后选择更改日期。

选择前一天、今天或第二天，然后按

OK，以选择节目表的日期。

#### 按风格搜索

如果该信息可用，您可按流派（如电影、体育等）查找已排定的节目。

要按流派搜索节目，请按  OPTIONS 并选择按流派搜索。

选择一个流派，然后按 OK

。此时会出现已找到节目的列表。

## 7.2

### 录音

您可从电视指南立即录制或安排录制电视节目。要存储这些录制内容，请将 USB 硬盘驱动器连接到电视。

## 7.3



### 接收电视指南数据

某些地区和某些频道可能不提供电视指南信息。这款电视可收集安装于其上的频道（例如使用观看电视功能收看到的频道）的电视指南信息，但无法收集从数字接收器或解码器观看的频道的电视指南信息。

这款电视拥有设置为来自广播商的信息。

设置电视指南信息

要设置电视指南信息...

1. 按  并选择电视指南。
2. 按  键。
3. 选择来自播放商。
4. 按 （如有必要，请反复按）关闭菜单。



# 来源

## 8.1

### 来源列表

您可在连接列表（“来源”菜单）中找到连接到电视的设备，还可从该“来源”菜单切换到设备。

#### “来源”菜单

要打开“来源”菜单，请按  SOURCES。

要切换到已连接的设备，

请使用 ◀（左）或 ▶（右）箭头选择设备，然后按 OK。

要关闭“来源

”菜单而不切换到设备，请再次按  SOURCES。



## 8.2

### 从待机模式

电视处于待机模式时，可使用电视遥控器打开已连接的设备。

#### 播放

要从待机模式同时打开光盘播放器和电视并立即开始播放光盘或节目，请按电视遥控器上的 ▶（播放）。

该设备应使用 HDMI

电缆进行连接，而且电视和该设备都必须将 HDMI CEC 处于开启状态。

#### 家庭影院系统

您可打开家庭影院系统，聆听音频光盘或无线电频道，并让电视处于待机模式。

如果要只打开 HTS

且电视处于待

机模式，请按电视遥控器上的  SOURCES。

## 8.3

### EasyLink

#### 借助

#### EasyLink

，您可使用电视遥控器操作已连接的设备。EasyLink 使用 HDMI CEC 来与已连接设备进行通信。这些设备必须支持 HDMI CEC 且必须使用 HDMI 连接进行连接。

---

# 定时器和时钟

---

## 9.1

### 定时关机

借助睡眠定时器，您可将电视设置为在预设时间后自动切换到待机模式。

要设置睡眠定时器...

1. 按 **▲** 并选择设置，然后按 OK。
2. 选择电视设置 > 一般设置 > 睡眠定时器。  
您可使用滑动条将该时间设置为最多 180 分钟（以 5 分钟为增量单位）。如果设置为 0 分钟，睡眠定时器将关闭。您始终可以提前关闭电视或在倒计时过程中重置该时间。
3. 按 **↩**（如有必要，请反复按）关闭菜单。

---

## 9.2

### 时钟

要想知道现在的时间，请按 **≡** TV GUIDE，以便在电视指南中找到时间。

在某些国家/地区，数字广播商不发送 UTC — 协调世界时信息。夏令时的变化可能会被忽略，电视可能会显示不正确的的时间。

要纠正电视时钟...

1. 按 **▲** 并选择设置，然后按 OK。
2. 选择电视设置 > 一般设置 > 时钟 > 自动时钟模式，然后选择取决于国家/地区。
3. 选择夏令时，然后选择相应的设置。

---

## 9.3

### 自动关熄

如果您在 4 小时内未按下遥控器上的键，或者如果电视在 10 分钟的时间里没有接收到任何输入信号或遥控器命令，电视会自动关闭以节省能源。

如果您将电视用作显示器或使用数字接收器观看电视（机顶盒 – STB），且您不使用电视的遥控器，则您应该禁用自动关闭功能。

要禁用自动关闭...

1. 按 **▲** 并选择设置，然后按 OK。
2. 选择电视设置 > 一般设置 > 自动关闭，然后将滑动条设置为 0（关闭）。
3. 按 **↩**（如有必要，请反复按）关闭菜单。

# 您的照片、视频和音乐

10.1

## 来自 USB 连接

### 您需要执行的操作

您可查看已连接的 USB 闪存盘或 USB 硬盘上的照片或者播放上面的音乐和视频。

#### 来自 USB 设备

打开电视后，将 USB 闪存盘或 USB 硬盘插入其中一个 USB 接口。电视会检测到该设备并列出现您的文件。如果列表没有自动出现，请按  SOURCES，选择浏览 USB，然后按 OK。



### 菜单栏

连接 USB 设备时，电视会按照类型对文件排序。导航到菜单栏，然后选择您要查找的文件类型。如果浏览电脑中的文件，则只能按照文件和文件夹在电脑上的整理方式浏览它们。

#### 菜单栏

导航到菜单栏，然后选择您希望观看或播放的文件类型。选择图片、音乐或电影。或者，您可以打开文件夹视图并浏览文件夹查找文件。

### 欣赏照片

在 USB 浏览器中，选择图片，然后按 OK。

#### 选项

按  OPTIONS。

- 开始幻灯片放映、停止幻灯片放映  
开始或停止幻灯片放映

- 幻灯片放映过渡  
设置从一张图片到下一张图片的过渡。

- 幻灯片放映频率  
选择每张照片的显示时间。

- 重复、播放一次  
反复查看图片或仅查看一次。

- 随机关闭、随机打开  
按顺序或随机查看图片。

- 旋转图像  
旋转照片。

- 显示信息  
显示图片名称、日期、大小和幻灯片放映中的下一张图片。

要关闭浏览 USB，请按 ，然后选择另一活动。

### 播放音乐

在 USB 浏览器中，选择音乐，然后按 OK。

#### 选项

按  OPTIONS。

- 停止播放  
停止音乐播放。

- 重复、播放一次  
反复播放歌曲或播放一次。

- 随机打开、随机关闭  
按顺序或随机播放歌曲。

- 显示信息  
显示文件名。

要关闭浏览 USB，请按 ，然后选择另一活动。

### 播放视频

在 USB 浏览器中，选择电影，然后按 OK。

#### 选项

按  OPTIONS。

- 字幕  
显示字幕 (如适用)。

- 音频语言  
播放音频语言 (如适用)。

- 重复/播放一次  
反复播放视频或播放一次。

- 随机播放开、随机播放关  
按顺序或随机播放视频。

- 显示信息  
显示文件名。

要关闭浏览 USB，请按 ，然后选择另一活动。

---

# Pause TV

---

## 11.1

### Pause TV

您可以暂停电视广播，稍后继续观看。只有数字电视频道可进行暂停操作。您必须连接 USB 硬盘才可缓冲广播。广播暂停的最大时间跨度为 90 分钟。

#### 暂停或继续广播

要暂停广播，请按

⏸ ( 暂停 )。屏幕上将短暂显示进度栏。

要调出进度栏，请再按一次 ⏸ ( 暂停 )。

要继续观看，请按

▶

( 播放 )。屏幕上的图标表示您正在观看已暂停的广播。

#### 返回到实际电视广播

要切换回实际电视广播，请按 ■ ( 停止 )。

一切换到数字频道，USB

硬盘就会开始缓冲广播。切换到另一数字频道时，USB 硬盘会缓冲新频道的广播，而之前频道的广播会被清除。切换到已连接的设备 ( 蓝光光盘播放机或数字接收器 ) 时，USB 硬盘会停止缓冲，广播亦会被清除。此外，将电视切换到待机模式下时，广播会被清除。

在 USB 硬盘上录制节目时，您无法暂停广播。

#### 即时回放

观看来自数字电视频道的广播时，您可以轻松地对广播进行即时回放。

要回放广播的最后 10 秒，请按 ⏸ ( 暂停 )，然后按 ◀ ( 左 )。

您可以反复按

◀，直至达到广播缓冲的起始点或最大时间跨度。

#### 进度栏

通过屏幕上的进度栏，按 ◀◀ ( 倒回 ) 或按 ▶▶

( 快进 ) 选择您希望从哪里开始观看已暂停的广播。反复按上述键可更改速度。

# 录制

## 12.1

### 您需要执行的操作

要录制电视节目，您需要...

- 将已连接的 USB 硬盘在此电视上进行格式化
- 在此电视上安装数字电视频道（使用观看电视功能收看到的频道）
- 接收内置电视指南的频道信息

## 12.2

### 录制节目

#### 立即录制

要录制您正在观看的节目，请按遥控器上的 **●**（录制）。

如果您接收来自广播商的电视指南信息，录制会立即开始。您可在录制列表中调整录制的结束时间。要停止录制，请按 **■**（停止）。

#### 排定录制

您可以排定今天或未来几天（最多 8 天）某个即将播出的节目的录制。

1. 要排定录制，请按 **≡** 电视指南。

在电视指南页面上，选择频道和您希望录制的节目。

您可以输入频道编号，以便在列表中跳到该频道。

按 **▶**（右）或 **◀**（左）滚动查看频道的节目。

要更改列表的日期，请按 **≡** OPTIONS

并选择更改日期。在列表中，选择所需的日期，然后按 OK。

2. 节目突出显示时，请按 **■** 录制

。此电视会在节目结尾处添加一定时间的缓冲。如有需要，您可以添加些额外的缓冲。

如果您打算在离开时录制节目，请记得将电视切换到待机模式并打开 USB 硬盘。

### 录制列表

要查看录制列表和已排定的录制，请按 **▲**，选择 **■** 录制，然后按 OK。

在此列表中，您可以选择要观看的录制节目，删除已录制的节目，调整正在录制的结束时间或检查可用磁盘空间。

从电视指南或录制列表中删除已排定的录制

- 按 **■** 列表以打开列表，然后按 **■**。
- 在电视指南中，选择已排定的录制节目，然后按 **■** 取消录制。

### 特别说明

- 录制节目时，您可以观看之前录制的节目。
- 录制过程中，您不能切换电视频道。
- 录制过程中，您不能暂停电视广播。
- 要进行录制，广播商需要可靠的时钟设置。如果您手动重置电视时钟，录制可能会失败。

## 12.3

### 观看录制

要观看录制...

1. 按 **▲**，选择 **■** 录制，然后按 OK。
2. 在列表中，选择该录制并按 **▶**（播放）开始播放。您可以使用遥控器上的 **▶▶**（快进）、**◀◀**（倒回）、**||**（暂停）或 **■**（停止）键。

失败的录制

如果排定的录制被广播商阻止或者广播中断，录制会被标记为失败。

# 设置

## 13.1

### 画面

#### 图像风格

为便于调整画面，您可以通过画面风格选择预设设置。

1. 观看电视频道时，按 **≡** OPTIONS 打开选项菜单。
2. 在菜单栏中选择画面和声音，然后选择画面风格。
3. 选择风格并按 OK。

以下为可用画面风格...

- 个人设定 - 您在快速图像设置中设置的首选项
- 鲜艳 - 适合白天观看
- 自然 - 自然图像设置
- 电影 - 适合观赏电影
- 节能 - 节能设置
- 标准 - 出厂标准设置
- 照片 - 适合欣赏照片

#### 调整画面风格

您可以调整画面风格...

1. 选择风格并按 OK。
2. 按 **▲** 并选择设置，然后按 OK。
3. 选择电视设置，导航至单独设置，然后进行调整。
4. 按 **↵** (如有必要，请反复按) 关闭菜单。

要恢复至原始画面风格值...

1. 按 **▲** 并选择设置，然后按 OK。
2. 选择电视设置 > 画面 > 画面风格并选择要重置的风格。
3. 选择恢复风格，然后按 OK。重置风格。

#### 鲜艳

如果将画面风格切换回鲜艳

，则每次打开电

视时，电视位置会设置为商店。该设置适用于店内促销。

要将电视设置为家用...

1. 按 **▲** 并选择设置，然后按 OK。
2. 选择电视设置 > 一般设置 > 位置并按 OK。
3. 选择家用并按 OK。
4. 按 **↵** (如有必要，请反复按) 关闭菜单。

### 图像设置

#### 背光对比度

通过背光对比度，您可以调整显示屏背光的亮度。

要调整级别...

1. 按 **▲** 并选择设置，然后按 OK。
2. 选择电视设置 > 画面 > 背光对比度。
3. 按 **▶** (右)，然后用 **▲** (上) 或 **▼** (下) 调整数值。
4. 按 **↵** (如有必要，请反复按) 关闭菜单。

#### 颜色

使用彩色可以调整画面的色彩饱和度。

要调整色彩...

1. 按 **▲** 并选择设置，然后按 OK。
2. 选择电视设置 > 画面 > 彩色。
3. 按 **▶** (右)，然后用 **▲** (上) 或 **▼** (下) 调整数值。
4. 按 **↵** (如有必要，请反复按) 关闭菜单。

#### 清晰度

使用清晰度可以调整画面的细节清晰度。

要调整清晰度...

1. 按 **▲** 并选择设置，然后按 OK。
2. 选择电视设置 > 画面 > 清晰度。
3. 按 **▶** (右)，然后用 **▲** (上) 或 **▼** (下) 调整数值。
4. 按 **↵** (如有必要，请反复按) 关闭菜单。

#### 降噪技术

通过降噪，您可以选择画面的降噪程度。

要设置降噪...

1. 按 **▲** 并选择设置，然后按 OK。
2. 选择电视设置 > 画面 > 降噪。
3. 按 **▶** (右)，然后选择关闭、最小、中等或最大。
4. 按 **↵** (如有必要，请反复按) 关闭菜单。

#### 减少压缩文件的残影

使用减少压缩文件的残影

可以使画面的数字转换更为流畅。压缩文件的残影大多呈现为画面中的小块或锯齿边缘。

要进行 MPEG 残象消除...

1. 按 **▲** 并选择设置，然后按 OK。
2. 选择电视设置 > 画面 > 减少压缩文件的残影。
3. 按 **▶** (右)，然后选择打开或关闭。
4. 按 **↵** (如有必要，请反复按) 关闭菜单。

#### 数码晶晰

通过数码晶晰

，您可以逐像素微调以与周围像素匹配，且提供清晰、高清图像。

1. 按 **▲** 并选择设置，然后按 OK。
2. 选择电视设置 > 画面 > 数码晶晰。
3. 按 **▶** (右)，然后选择设置。
4. 按 **↵** (如有必要，请反复按) 关闭菜单。

不同的设置为...

- 高清晰度 -

启用非凡清晰度，尤其是在画面的线条和轮廓上。

- 动态对比度 -

动态增强画面在全黑、中等亮度和明亮区域中的细节。

- 动态背光 -

选择背景灯光等级以优化动态功耗和画面对比度。

- 彩色增强 - 动态增强色彩明亮度和细节。

---

## 高级画面设置

---

### 伽马校正

通过伽马校正

，您可以调整画面亮度和对比度的非线性设置。

要调整级别...

1. 按 **▲** 并选择设置，然后按 OK。
2. 选择电视设置 > 画面 > 高级 > 伽马校正。
3. 按 **▶** (右)，然后用 **▲** (上) 或 **▼** (下) 调整数值。
4. 按 **↩** (如有必要，请反复按) 关闭菜单。

---

### 色调

通过色调，您可以更改色彩平衡。

要选择预设...

1. 按 **▲** 并选择设置，然后按 OK。
2. 选择电视设置 > 画面 > 高级 > 色彩。
3. 按 **▶** (右)，然后选择普通、暖色或冷色。如果想自己设置色温，可以选择自定义。
4. 按 **↩** (如有必要，请反复按) 关闭菜单。

---

### 自定义色彩

使用自定义色彩

可自行设置

色温。要设置自定义色

彩，请先在色彩设置中选择自定义

，调出“自定义色彩”菜单。自定义色彩设置适用于专业用户。

要设置自定义色温...

1. 按 **▲** 并选择设置，然后按 OK。
  2. 选择电视设置 > 画面 > 高级 > 自定义色彩。
  3. 按 **▶** (右)。
  4. 用键头箭选择设置。(WP 是白点，BL 是黑色水平。)
  5. 按 OK
- 确认设置。您也可以在该菜单中选择任一预设设置。
6. 按 **↩** (如有必要，请反复按) 关闭菜单。

---

### 视频对比度

通过视频对比度，您可以降低视频对比度范围。

要调整级别...

1. 按 **▲** 并选择设置，然后按 OK。
2. 选择电视设置 > 画面 > 高级 > 视频对比度。
3. 按 **▶** (右)，然后用 **▲** (上) 或 **▼** (下) 调整数值。
4. 按 **↩** (如有必要，请反复按) 关闭菜单。

---

### 亮度

使用亮度

可以设置画面信号的亮度级别。亮度设置适用于专业用户。建议非专业用户用背光对比度调整亮度。

要调整级别...

1. 按 **▲** 并选择设置，然后按 OK。
2. 选择电视设置 > 画面 > 高级 > 亮度。
3. 按 **▶** (右)，然后用 **▲** (上) 或 **▼** (下) 调整数值。
4. 按 **↩** (如有必要，请反复按) 关闭菜单。

---

## 13.2

### 游戏或电脑

您可以将电视切换至针对游戏的最适合的画面设置或将电视作为电脑显示器。系统针

对游戏或电脑

有不同的设置。如果设备的来源菜单中具有针对游戏控制台或电脑的正确类型设置，则切换设备时电视会自动切换至最适合的相应设置。如果手动切换设置，在切换至观看电视或其他所连接的设备时不要忘记将其关闭。

要手动切换设置...

1. 按 **▲** 并选择设置，然后按 OK。
2. 选择电视设置 > 画面 > 高级 > 游戏或电脑。
3. 选择游戏、电脑或电视。设置为电视将返回适合观看电视的画面设置。
4. 按 **↩** (如有必要，请反复按) 关闭菜单。

---

## 13.3

### 格式和边缘

---

#### 画面格式

如果黑条出现在画面顶部和底部，或者两边都有，那么可将画面格式调整为充满屏幕的格式。

要更改画面格式...

1. 观看电视频道时，按 **⏏** 打开画面格式菜单。
2. 从列表中选择一种格式，然后按 OK。

---

#### 屏幕边缘

使用屏幕边缘可以稍微放大画面以隐藏失真的边缘。

要调整边缘...

1. 按 **▲** 并选择设置，然后按 OK。
2. 选择电视设置 > 画面 > 格式和边缘 > 屏幕边缘。
3. 按 **▶** (右)，然后用 **▲** (上) 或 **▼** (下) 调整数值。
4. 按 **↩** (如有必要，请反复按) 关闭菜单。



## 声音

### 声音风格

为便于声音调节，您可以通过声音风格选择预设设置。



1. 观看电视频道时，按  OPTIONS 打开选项菜单。
2. 在菜单栏中选择“画面和声音”，然后选择声音风格。
3. 选择声音风格并按 OK。

以下为不同声音风格...

- 个性化 - 您在定制画面和声音中所做的个性化选择
- 原始 - 出厂标准
- 电影 - 适合观赏电影
- 新闻 - 适合语音
- 音乐 - 适合听音乐
- 游戏 - 适合游戏

### 调整声音风格

您可以调整声音风格...

1. 选择风格并按 OK。
2. 按  并选择设置，然后按 OK。
3. 选择电视设置，导航至单独设置，然后进行调整。
4. 按  关闭菜单并存储设置。

要恢复至原始声音风格值...





1. 按  并选择设置，然后按 OK。
2. 选择电视设置 > 声音 > 恢复风格。

## 声音设置

### 低音

使用低音可以调整声音的低音级别。





要调整级别...

1. 按  并选择设置，然后按 OK。
2. 选择电视设置 > 声音 > 低音。
3. 按  (右)，然后用  (上) 或  (下) 调整数值。
4. 按  (如有必要，请反复按) 关闭菜单。

### 高音

使用高音可以调整声音的高音级别。



要调整级别...

1. 按  并选择设置，然后按 OK。
2. 选择电视设置 > 声音 > 高音。
3. 按  (右)，然后用  (上) 或  (下) 调整数值。
4. 按  (如有必要，请反复按) 关闭菜单。

### 环绕模式

使用环绕模式可以设置电视扬声器的音效。





要设置环绕模式...

1. 按  并选择设置，然后按 OK。
2. 选择电视设置 > 声音 > 环绕模式。
3. 按  (右)，然后选择立体声或环绕立体声。
4. 按  (如有必要，请反复按) 关闭菜单。

### 耳机音量

使用耳机音量可以单独设置所连接的耳机的音量。

要调节音量...

1. 按  OPTIONS，然后在菜单栏中选择画面和声音。
2. 按  (右)，选择耳机音量，然后按 OK。
3. 按  (向上) 或  (向下) 调节音量。
4. 按  (如有必要，请反复按) 关闭菜单。



### 高级声音设置

#### 自动音量调节

使用自动音量调节

可以将电视设置为自动调节突然出现的音量差异。这种情况通常出现在广告开头或切换频道时。

要打开或关闭...

1. 按  并选择设置，然后按 OK。
2. 选择电视设置 > 声音 > 高级 > 自动音量调节。
3. 按  (右)，然后选择打开或关闭。
4. 按  (如有必要，请反复按) 关闭菜单。

### 电视扬声器

您可以将电视声音输出至所连接的音频设备 - 家庭影院系统或音频系统

。使用电视扬声器

可以选择在哪听到以及如何控制电视声音。

- 如果选择关闭，则会永久关闭电视扬声器。
- 如果选择打开，则会始终打开电视扬声器。

通过 HDMI CEC 功能连接音频设备时可以使用任一 EasyLink 设置。

- 如果选择 EasyLink

，则电视可将声音输出至音频设备。当设备播放声音时电视将关闭电视扬声器。

- 如果选择 EasyLink

自动开始

，则电视将打开音频设备，将声音输出至音频设备并关闭电视扬声器。

选中 EasyLink 或 EasyLink

自动开始

后，您仍可以在“画面和声音”菜单中切换至电视扬声器或设备扬声器。

## 要设置电视扬声器...

1. 按 **▲** 并选择设置，然后按 OK。
2. 选择电视设置 > 声音 > 高级 > 电视扬声器。
3. 按 **▶** (右) 并选择关闭、开启、EasyLink 或 EasyLink 自动开始。
4. 按 **↶** (如有必要，请反复按) 关闭菜单。

## 要直接切换扬声器...

1. 观看电视时，按 **≡** OPTIONS，然后选择画面和声音。
2. 选择扬声器，然后选择电视或功放器 (音频设备)。
3. 按 **↶** (如有必要，请反复按) 关闭菜单。

## 清晰声效

使用 Clear sound 可以改善人声。适用于新闻节目。您可以打开或关闭人声改善。

## 要打开或关闭...

1. 按 **▲** 并选择设置，然后按 OK。
2. 选择电视设置 > 声音 > 高级 > Clear sound。
3. 按 **▶** (右)，然后选择打开或关闭。
4. 按 **↶** (如有必要，请反复按) 关闭菜单。

## HDMI1-ARC

如果在所有 HDMI 接口上均不需要音频回传通道 (ARC)，则可以关闭 ARC 信号。

## 音频输出格式

### 使用音频输出格式

可以设置电视音频输出信号以配合家庭影院系统的声音处理功能。

## 音频输出调衡

当您在家庭影院系统和电视之间来回切换时，使用音频输出调衡可以调衡二者的音量。

## 音频输出延迟

如果在家庭影院系统上设置音频同步延迟，要实现声画同步，必须在电视上关闭音频输出延迟。

## 音频输出修正

音频输出修正设置延迟。

# 音箱

## 家庭影院系统

您可以将电视声音输出至所连接的音频设备 - 家庭影院系统或音频系统。

您可以选择在哪听到以及如何控制电视声音。

- 如果选择关闭，则会永久关闭电视扬声器。
- 如果选择电视扬声器，则会始终打开电视扬声器。

通过 HDMI CEC 功能连接音频设备时可以使用任一 EasyLink 设置。

- 如果选择 EasyLink，则电视可将声音输出至音频设备。当设备播放声音时电视将关闭电视扬声器。

- 如果选择 EasyLink

自动开始

，则电视将打开音频设备，将声音输出至音频设备并关闭电视扬声器。

选择 EasyLink 或 EasyLink

自动开始后，您仍可以切换至电视扬声器 (如有必要)。

## 要设置电视扬声器...

1. 按 **▲** 并选择设置，然后按 OK。
2. 选择电视设置 > 声音 > 声音输出。
3. 按 **▶** (右) 并选择关闭、电视扬声器、EasyLink 或 EasyLink 自动开始。
4. 按 **↶** (如有必要，请反复按) 关闭菜单。

## 要直接切换至扬声器...

1. 观看电视时，按 **⊙**。
2. 选择扬声器，然后选择电视或功放器 (音频系统)。
3. 按 **↶** (如有必要，请反复按) 关闭菜单。

# 电视摆放

## 作为首次安装

的一部分，需将该设置设置

为在电视支架上或壁装

。如果此后更改过电视摆放方式，则需进行相应调整以获得最佳音质。



1. 按 **▲** 并选择设置，然后按 OK。
2. 选择电视设置 > 一般设置 > 电视摆放，然后按 OK。
3. 选择在电视支架上或壁装，然后按 OK。
4. 按 **↶** (如有必要，请反复按) 关闭菜单。

# 规格

## 14.1

### 环境

#### 节约电能

环保设置可捆绑有助于环保的设置。  
观看电视频道时，按  可打开环保设置。  
活动设置标有 。您可以用 OK  
键标记或取消标记各设置。  
再次按  可关闭环保设置。

#### 节能

该画面风格可以最理想的节能设置来设置画面。

#### 屏幕关闭

如果只是听音乐，可关闭电视屏幕以节省能源。  
选择屏幕关闭，然后按  
OK。要重新打开屏幕，请按遥控器上的任意键。

#### 自动关熄

如果在 4 小时内未按遥控器的按键，或电视 10  
分钟未接收到信号，则电视会自动关闭以节能。  
如果将电视用作显示器或用数字接收器观看电视（机顶盒  
- STB），则无需使用电视遥控器，禁用自动关机。

除了环保设置，电视还具有与节能相关的环保技术。

#### 非活动设备关闭

关闭相连的 EasyLink HDMI-  
CEC（消费电子产品控制）非活动兼容设备。

#### 电源管理

本电视的高级电源管理可确保最有效地使用能源。您可以  
查看个性化电视设置、当前屏幕画面的亮度级别和周围光  
线条件对相对功耗有何影响。  
要查看相对功耗...

1. 按  并选择设置，然后按 OK。
2. 选择观看演示 > Active Control 演示，然后按 OK。
3. 选择设置以查看相应值。

### 欧洲能源标签

#### 欧洲能源标签

会提示您本产品的能效等级。本产品的能效等级越高，能  
耗就越低。

在标签上，您可以找到本产品使用时的能效等级和 1  
年的平均能耗。您也可以在您所在国家/地区的飞利浦网站  
[www.philips.com/TV](http://www.philips.com/TV) 上找到本产品的功耗值

### 使用终止

#### 弃置旧产品和电池

本产品是采用优质的材料和元件设计和制造的，可以回收  
利用。



如果产品上贴有带叉的轮式垃圾桶符号，则表示此产品符  
合欧盟指令 2002/96/EC。



请熟悉当地针对电子和电器产品制订的分门别类的收集机  
制。

请遵循当地的规章制度，不要将旧产品与普通生活垃圾一  
同弃置。正确弃置旧产品有助于避免对环境和人类健康造  
成潜在的负面影响。

该产品含有符合欧洲指令 2006/66/EC  
的电池，不能与一般的生活垃圾一同弃置。



请了解当地有关单独收集电池的规章制度，因为正确弃置  
将有助于避免对环境和人类健康造成负面影响。

## 14.2

### PxHxxx9/PxTxxx9 的接收

- 天线输入：75 欧姆同轴 (IEC75)
- 调谐器频段：Hyperband、S-Channel、UHF、VHF
- DVB：DVB-T（地面、天线）COFDM 2K/8K；DVB-  
T2：仅适用于“... T/12”电视类型；DVB-C（有线）QAM
- 模拟视频播放：NTSC、SECAM、PAL
- 数字视频播放：MPEG2 SD/HD (ISO/IEC  
13818-2)、MPEG4 SD/HD (ISO/IEC 14496-10)
- 数字音频播放 (ISO/IEC 13818-3)

## 14.3

### 显示屏

#### 类型

屏幕对角线尺寸：

- 32Pxx43x9：81 厘米/32 英寸
- 40Pxx43x9：102 厘米/40 英寸
- 50Pxx43x9：127 厘米/50 英寸

显示屏分辨率：

- PFxxx9 : 1920x1080p
- PHxxx9 : 1366x768p

---

## 显示屏分辨率

电脑格式 - HDMI (分辨率 - 刷新率)

- 640 x 480 - 60 赫兹
- 800 x 600 - 60 赫兹
- 1024 x 768 - 60 赫兹
- 1280 X 720 - 60 赫兹
- 1280 X 768 - 60 赫兹
- 1280 x 1024 - 60 赫兹
- 1360 x 768 - 60 赫兹
- 1600 x 900 - 60 赫兹\*
- 1680 x 1050 - 60 赫兹\*
- 1920 x 1080 - 60 赫兹\*

电脑格式 - VGA (分辨率 - 刷新率)

- 640 x 480 - 60 赫兹
- 800 x 600 - 60 赫兹
- 1024 x 768 - 60 赫兹
- 1280 x 1024 - 60 赫兹
- 1360 x 768 - 60 赫兹
- 1600 x 900 - 60 赫兹\*
- 1600 x 1200 - 60 赫兹\*
- 1920 x 1080 - 60 赫兹\*

视频格式 (分辨率 - 刷新率)

- 480i - 60 赫兹
- 480p - 60 赫兹
- 576i - 50 赫兹
- 576p - 50 赫兹
- 720p - 50 赫兹、60 赫兹
- 1080i - 50 赫兹、60 赫兹
- 1080p - 24赫兹、25 赫兹、30 赫兹、50 赫兹、60 赫兹

\* 仅适用于某些设备。

---

14.4

## 功率

产品规格如有更改，恕不另行通知。有关本产品的详细规格，请参见 [www.philips.com/support](http://www.philips.com/support)

功率

- 电源：交流 220-240 伏 +/-10%
- 环境温度：5°C 至 35°C
- 待机功耗：小于 0.3 瓦
- 节能功能：环保模式、画面隐藏（适用于收音机）、自动关闭、环保设置菜单。

产品铭牌上标注的额定功率是本产品正常家用时的功耗 (IEC 62087

Ed.2)。括号中注明的最大额定功率用于确保电气安全 (IEC 60065 Ed. 7.2)。

---

14.5

## 尺寸和重量 \_ 43x9

32Pxx43x9

- 不含电视支架：  
宽 726.5 毫米 - 高 424.3 毫米 - 深 63.6 毫米 - 重量 ±5 千克

- 含电视支架：  
宽 726.5 毫米 - 高 485.3 毫米 - 深 186.2 毫米 - 重量 ±5.6 千克

40Pxx43x9

- 不含电视支架：  
宽 903.5 毫米 - 高 523.1 毫米 - 深 88.1 毫米 - 重量 ±7.73 千克

- 含电视支架：  
宽 903.5 毫米 - 高 570.8 毫米 - 深 243.1 毫米 - 重量 ±9.9 千克

50Pxx43x9

- 不含电视支架：  
宽 1123.6 毫米 - 高 658 毫米 - 深 88 毫米 - 重量 ±12.4 千克

- 含电视支架：  
宽 1123.6 毫米 - 高 706 毫米 - 深 252.8 毫米 - 重量 ±14.8 千克

---

14.6

## 连接

适用于 PxKxxx9

电视背面

- HDMI 1 ARC：HDMI 音频回传通道
- HDMI 2
- SERV. U：服务端口
- 电视天线：75 欧姆同轴 (IEC)
- SCART (RGB/CVBS)：SCART 适配器
- 音频输入 (DVI)：立体声 3.5 毫米迷你插孔
- 数字音频输出：SPDIF
- 耳机：立体声 3.5 毫米迷你插孔

电视侧面

- CI：通用接口
- USB
- 卫星

适用于 PxHxxx9/PxTxxx9

电视背面

- HDMI 1 ARC : HDMI 音频回传通道
- HDMI 2
- SERV. U : 服务端口
- 电视天线 : 75 欧姆同轴 (IEC)
- SCART (RGB/CVBS) : SCART 适配器
- 音频输入 (DVI) : 立体声 3.5 毫米迷你插孔
- 数字音频输出 : SPDIF
- 耳机 : 立体声 3.5 毫米迷你插孔

电视侧面

- CI : 通用接口
- USB

14.7

## 多媒体

注意：多媒体文件名不能超过 128 个字符。

支持的多媒体连接

- USB 2.0 (FAT / FAT 32 / NTFS) : 只能连接消耗 500 毫安或更少电流的 USB 设备。

支持的图像文件

- JPEG : \*.jpg、\*.jpeg
- PNG : \*.png.jpg

支持的音频文件

- MPEG1 : \*.mp3

支持的视频文件

- \*.avi、\*.mp4、\*.mov、\*.mkv、\*.mpg、\*.mpeg

支持的字幕格式

- SRT : 多语言支持

支持的音频/视频格式

File Extensions	Container	Video Decoder	Resolution	Audio Decoder
*.avi	AVI	x264 - H.264/AVC encoder (X264), 1920x1080, 30 fps MPEG Layer3, 192 kBit/s, 48,000 Hz, Stereo	1920 x 1080	MP3, MP2, AC3
		XviD	1920 x 1080	MP3, MP2
		MPEG1	768 x 576	MP3, MP2, AC3
		MPEG2	1920 x 1080	MP3, MP2, AC3
		H.264	1920 x 1080	MP3, MP2, AC3
		MPEG-4	1920 x 1080	MP3, MP2, AC3
*.mp4 *.mov		H.264	1920 x 1080	MP3
		MPEG-4	1920 x 1080	MP3
*.mkv	MKV	H.264	1920 x 1080	MP3, AC3
		MPEG-4	1920 x 1080	MP3, MP2, AC3
*.mpg *.mpeg	PS (Program Stream)	MPEG1	768 x 576	MP2, AC3
		MPEG2	1920 x 1080	MP2, AC3

File Extensions	Container	Video Decoder	Resolution	Audio Decoder
Others	TS (Transport Stream)	MPEG2	1920 x 1080	MP2, AC3
		H.264	1920 x 1080	MP2, AC3

# 软件

## 15.1

### 软件更新

#### 通过 USB 更新

可能有必要更新电视软件。您需要电脑和将软件上传至电视的 USB 存储设备。使用具有 256MB 可用空间的 USB 存储设备。确保关闭写保护。

##### 1. 在电视上开始更新

要开始软件更新...

再次按 **▲**，选择设置，然后按 OK。

选择更新软件 > USB，然后按 OK。

##### 2. 识别电视

将 USB 存储设备插入电视的任一 USB 接口。

选择开始，然后按 OK。标识文件将写入 USB 存储设备。

##### 3. 下载电视软件

将 USB 存储设备插入电脑。

在 USB 存储设备上，找到 update.htm 文件并双击。

单击发送 ID。

如果有新软件可用，则下载 .zip 文件。

下载后，解压文件并将 autorun.upg 文件复制至 USB 存储设备。

请勿将该文件放入文件夹。

##### 4. 更新电视软件

将 USB 存储设备再次插入电视。更新将自动开始。电视会自行关闭 10 秒钟后重新打开。请稍候。

请勿...

- 使用遥控器

- 从电视中取出 USB 存储设备。

如果更新时发生了断电，请勿从电视中取出 USB 存储设备。恢复供电后，更新会继续进行。

## 15.2

### 软件版本

要查看当前电视软件版本...

1. 按 **▲** 并选择设置，然后按 OK。

2. 选择软件设置，然后按 OK。

3. 选择当前软件信息，查看发行版本。

4. 按 **↵** (如有必要，请反复按) 关闭菜单。

## 15.3

### 开放源软件

本电视包含开源软件。TP Vision Europe B.V. 特此承诺，根据用户的要求并提供相应的许可，我们将向其提供本产品中使用的受版权保护的开源软件包的对应完整源代码副本。

本承诺自任何人购买本产品并收到此信息后三年内有效。要获得源代码，请用英文写信发送至...

Intellectual Property Dept.

TP Vision Europe B.V.

Prins Bernhardplein 200

1097 JB Amsterdam

The Netherlands

## 15.4

### Open source license

Acknowledgements and License Texts for any open source software used in this product.

This is a document describing the distribution of the source code used in this product, which fall either under the GNU General Public License (the GPL), or the GNU Lesser General Public License (the LGPL), or any other open source license.

Instructions to obtain source code for this software can be found in the documentation supplied with this product.

TP VISION MAKES NO WARRANTIES WHATSOEVER, EITHER EXPRESS OR IMPLIED, INCLUDING ANY WARRANTIES OF MERCHANTABILITY OR FITNESS FOR A PARTICULAR PURPOSE, REGARDING THIS SOFTWARE. TP Vision offers no support for this software. The preceding does not affect your warranties and statutory rights regarding any product(s) you purchased. It only applies to this source code made available to you.

zlib (1.2.7) A massively spiffy yet delicately unobtrusive compression library. Source: <http://www.zlib.net/> This piece of software is made available under the terms and conditions of the zlib license, which can be found below.

libjpeg (6b) It is a widely used C library for reading and writing JPEG image files. Source: <http://libjpeg.sourceforge.net/> This piece of software is made available under the terms and conditions of the JPEG license, which can be found below.

sqlite3 (3.7.14) SQLite is a C library that implements an SQL database engine. Programs that link with the SQLite library can have SQL database access without running a separate RDBMS process.

Source:

<http://linuxappfinder.com/package/sqlite3-0> This piece of software is made available under the terms and conditions of the SQLite public domain license, which can be found below.

OpenSSL (1.0.0.d) A toolkit implementing SSL v2/v3 and TLS protocols with full-strength cryptography world-wide. Source: [www.openssl.org](http://www.openssl.org) This piece of software is made available under the terms and conditions of the Apache license, which can be found below.

libboost (1.51) Provides a repository for free peer-reviewed portable C++ source libraries. The emphasis is on libraries which work well with the C++ standard library. Source: [www.boost.org](http://www.boost.org) This piece of software is made available under the terms and conditions of the Boost license, which can be found below.

libdirectfb (1.4.11) DirectFB is a graphics library which was designed with embedded systems in mind. It offers maximum hardware accelerated performance at a minimum of resource usage and overhead. Source: <http://directfb.org> This piece of software is made available under the terms and conditions of the GNU Lesser General Public License, which can be found below.

libTomMath (0.42.0) A free open source portable number theoretic multiple-precision integer library written entirely in C. Source: <http://libtom.org/> This piece of software is made available under the terms and conditions of the WTFPL license, which can be found at this site: [www.wtfpl.net/txt/copying](http://www.wtfpl.net/txt/copying)

MTD utility (1.5.0) MTD subsystem (Memory Technology Devices) provides an abstraction layer for raw flash devices. It makes it possible to use the same API when working with different flash types and technologies, e.g. NAND, OneNAND, NOR, AG-AND, ECC'd NOR, etc. MTD subsystem does not deal with block devices like MMC, eMMC, SD, CompactFlash, etc. These devices are not raw flashes but they have a Flash Translation layer inside, which makes them look like block devices. These devices are the subject of the Linux block subsystem, not MTD.

Source: <http://www.linux-mtd.infradead.org/source.html> This piece of software is made available under the terms and conditions of the GNU General Public License, which can be found below.

FFmpeg (0.6) Cross-platform solution to record, convert and stream audio and video. It includes libavcodec - the leading audio/video codec library. Source: [www.ffmpeg.org](http://www.ffmpeg.org) This piece of software is made available under the terms and conditions of the GNU Lesser General Public License version 2.1 or GNU General Public License version 2, which can be found below.

---

zlib LICENSE `zlib.h` -- interface of the 'zlib' general purpose compression library version 1.2.8, April 28th, 2013

Copyright (C) 1995-2013 Jean-loup Gailly and Mark Adler  
This software is provided 'as-is', without any express or implied warranty. In no event will the authors be held liable for any damages arising from the use of this software.

Permission is granted to anyone to use this software for any purpose, including commercial applications, and to

alter it and redistribute it freely, subject to the following restrictions:

1. The origin of this software must not be misrepresented; you must not claim that you wrote the original software. If you use this software in a product, an acknowledgment in the product documentation would be appreciated but is not required.
2. Altered source versions must be plainly marked as such, and must not be misrepresented as being the original software.
3. This notice may not be removed or altered from any source distribution.

Jean-loup Gailly ([jloup@gzip.org](mailto:jloup@gzip.org)) Mark Adler ([madler@alumni.caltech.edu](mailto:madler@alumni.caltech.edu))

---

Boost Software License - Version 1.0 - August 17th, 2003  
Permission is hereby granted, free of charge, to any person or organization obtaining a copy of the software and accompanying documentation covered by this license (the "Software") to use, reproduce, display, distribute, execute, and transmit the Software, and to prepare derivative works of the Software, and to permit third-parties to whom the Software is furnished to do so, all subject to the following:

The copyright notices in the Software and this entire statement, including the above license grant, this restriction and the following disclaimer, must be included in all copies of the Software, in whole or in part, and all derivative works of the Software, unless such copies or derivative works are solely in the form of machine-executable object code generated by a source language processor.

THE SOFTWARE IS PROVIDED "AS IS", WITHOUT WARRANTY OF ANY KIND, EXPRESS OR IMPLIED, INCLUDING BUT NOT LIMITED TO THE WARRANTIES OF MERCHANTABILITY, FITNESS FOR A PARTICULAR PURPOSE, TITLE AND NON-INFRINGEMENT. IN NO EVENT SHALL THE COPYRIGHT HOLDERS OR ANYONE DISTRIBUTING THE SOFTWARE BE LIABLE FOR ANY DAMAGES OR OTHER LIABILITY, WHETHER IN CONTRACT, TORT OR OTHERWISE, ARISING FROM, OUT OF OR IN CONNECTION WITH THE SOFTWARE OR THE USE OR OTHER DEALINGS IN THE SOFTWARE.

---

Independent JPEG Group's free JPEG software This package contains C software to implement JPEG image encoding, decoding, and transcoding. JPEG is a standardized compression method for full-color and gray-scale images.

The distributed programs provide conversion between JPEG "JFIF" format and image files in PBMPLUS PPM/PGM, GIF, BMP, and Targa file formats. The core compression and decompression library can easily be reused in other programs, such as image viewers. The package is highly portable C code; we have tested it on many machines ranging from PCs to Crays.

We are releasing this software for both noncommercial and commercial use.

Companies are welcome to use it as the basis for JPEG-

related products. We do not ask a royalty, although we do ask for an acknowledgement in product literature (see the README file in the distribution for details). We hope to make this software industrial-quality --- although, as with anything that's free, we offer no warranty and accept no liability. For more information, contact jpeg-info@jpegclub.org.

Contents of this directory jpegsr.vN.tar.gz contains source code, documentation, and test files for release N in Unix format.

jpegsrN.zip contains source code, documentation, and test files for release N in Windows format.

jpegaltui.vN.tar.gz contains source code for an alternate user interface for cjpeg/djpeg in Unix format.

jpegaltuiN.zip contains source code for an alternate user interface for cjpeg/djpeg in Windows format.

wallace.ps.gz is a PostScript file of Greg Wallace's introductory article about JPEG. This is an update of the article that appeared in the April 1991 Communications of the ACM.

jpeg.documents.gz tells where to obtain the JPEG standard and documents about JPEG-related file formats.

jfif.ps.gz is a PostScript file of the JFIF (JPEG File Interchange Format) format specification.

jfif.txt.gz is a plain text transcription of the JFIF specification; it's missing a figure, so use the PostScript version if you can.

TIFFTechNote2.txt.gz is a draft of the proposed revisions to TIFF 6.0's JPEG support.

pm.errata.gz is the errata list for the first printing of the textbook "JPEG Still Image Data Compression Standard" by Pennebaker and Mitchell.

jdosaobj.zip contains pre-assembled object files for JMEMDOS.ASM. If you want to compile the IJG code for MS-DOS, but don't have an assembler, these files may be helpful.

---

Expat LICENSE Copyright (c) 1998, 1999, 2000 Thai Open Source Software Center Ltd

Permission is hereby granted, free of charge, to any person obtaining a copy of this software and associated documentation files (the "Software"), to deal in the Software without restriction, including without limitation the rights to use, copy, modify, merge, publish, distribute, sublicense, and/or sell copies of the Software, and to permit persons to whom the Software is furnished to do so, subject to the following conditions:

The above copyright notice and this permission notice shall be included in all copies or substantial portions of the Software.

THE SOFTWARE IS PROVIDED "AS IS", WITHOUT WARRANTY OF ANY KIND, EXPRESS OR IMPLIED, INCLUDING BUT NOT LIMITED TO THE WARRANTIES OF MERCHANTABILITY, FITNESS FOR A PARTICULAR PURPOSE AND NONINFRINGEMENT. IN NO EVENT SHALL THE AUTHORS OR COPYRIGHT

HOLDERS BE LIABLE FOR ANY CLAIM, DAMAGES OR OTHER LIABILITY, WHETHER IN AN ACTION OF CONTRACT, TORT OR OTHERWISE, ARISING FROM, OUT OF OR IN CONNECTION WITH THE SOFTWARE OR THE USE OR OTHER DEALINGS IN THE SOFTWARE.

---

DirectFB LICENSE (c) Copyright 2001-2007 The DirectFB Organization (directfb.org) (c) Copyright 2000-2004 Convergence (integrated media) GmbH All rights reserved.

Written by Denis Oliver Kropp <dok@directfb.org>, Andreas Hundt <andi@fischlustig.de>, Sven Neumann <neo@directfb.org>, Ville Syrjälä <syrjala@sci.fi> and Claudio Ciccani <klan@users.sf.net>.

This library is free software; you can redistribute it and/or modify it under the terms of the GNU Lesser General Public License as published by the Free Software Foundation; either version 2 of the License, or (at your option) any later version. The complete text of the license is found in the file COPYING.

---

GNU General Public LICENSE version 2 (GPLv2) Copyright (C) 1989, 1991 Free Software Foundation, Inc. 59 Temple Place, Suite 330, Boston, MA 02111-1307 USA

Everyone is permitted to copy and distribute verbatim copies of this license document, but changing it is not allowed.

Preamble The licenses for most software are designed to take away your freedom to share and change it. By contrast, the GNU General Public License is intended to guarantee your freedom to share and change free software--to make sure the software is free for all its users.

This General Public License applies to most of the Free Software Foundation's software and to any other program whose authors commit to using it. (Some other Free Software Foundation software is covered by the GNU Library General Public License instead.) You can apply it to your programs, too.

When we speak of free software, we are referring to freedom, not price. Our General Public Licenses are designed to make sure that you have the freedom to distribute copies of free software (and charge for this service if you wish), that you receive source code or can get it if you want it, that you can change the software or use pieces of it in new free programs; and that you know you can do these things

To protect your rights, we need to make restrictions that forbid anyone to deny you these rights or to ask you to surrender the rights. These restrictions translate to certain responsibilities for you if you distribute copies of the software, or if you modify it.

For example, if you distribute copies of such a program, whether gratis or for a fee, you must give the recipients all the rights that you have. You must make sure that they, too, receive or can get the source code. And you



must show them these terms so they know their rights. We protect your rights with two steps: (1) copyright the software, and (2) offer you this license which gives you legal permission to copy, distribute and/or modify the software.

Also, for each author's protection and ours, we want to make certain that everyone understands that there is no warranty for this free software. If the software is modified by someone else and passed on, we want its recipients to know that what they have is not the original, so that any problems introduced by others will not reflect on the original authors' reputations.

Finally, any free program is threatened constantly by software patents. We wish to avoid the danger that redistributors of a free program will individually obtain patent licenses, in effect making the program proprietary. To prevent this, we have made it clear that any patent must be licensed for everyone's free use or not licensed at all.

The precise terms and conditions for copying, distribution and modification follow.

#### TERMS AND CONDITIONS FOR COPYING, DISTRIBUTION AND MODIFICATION

0. This License applies to any program or other work which contains a notice placed by the copyright holder saying it may be distributed under the terms of this General Public License. The "Program", below, refers to any such program or work, and a "work based on the Program" means either the Program or any derivative work under copyright law: that is to say, a work containing the Program or a portion of it, either verbatim or with modifications and/or translated into another language. (Hereinafter, translation is included without limitation in the term "modification".) Each licensee is addressed as "you".

Activities other than copying, distribution and modification are not covered by this License; they are outside its scope. The act of running the Program is not restricted, and the output from the Program is covered only if its contents constitute a work based on the Program (independent of having been made by running the Program). Whether that is true depends on what the Program does.

1. You may copy and distribute verbatim copies of the Program's source code as you receive it, in any medium, provided that you conspicuously and appropriately publish on each copy an appropriate copyright notice and disclaimer of warranty; keep intact all the notices that refer to this License and to the absence of any warranty; and give any other recipients of the Program a copy of this License along with the Program.

You may charge a fee for the physical act of transferring a copy, and you may at your option offer warranty protection in exchange for a fee.

2. You may modify your copy or copies of the Program or any portion of it, thus forming a work based on the Program, and copy and distribute such modifications or

work under the terms of Section 1 above, provided that you also meet all of these conditions: a) You must cause the modified files to carry prominent notices stating that you changed the files and the date of any change. b) You must cause any work that you distribute or publish, that in whole or in part contains or is derived from the Program or any part thereof, to be licensed as a whole at no charge to all third parties under the terms of this License. c) If the modified program normally reads commands interactively when run, you must cause it, when started running for such interactive use in the most ordinary way, to print or display an announcement including an appropriate copyright notice and a notice that there is no warranty (or else, saying that you provide a warranty) and that users may redistribute the program under these conditions, and telling the user how to view a copy of this License. (Exception: if the Program itself is interactive but does not normally print such an announcement, your work based on the Program is not required to print an announcement.)

These requirements apply to the modified work as a whole. If identifiable sections of that work are not derived from the Program, and can be reasonably considered independent and separate works in themselves, then this License, and its terms, do not apply to those sections when you distribute them as separate works. But when you distribute the same sections as part of a whole which is a work based on the Program, the distribution of the whole must be on the terms of this License, whose permissions for other licensees extend to the entire whole, and thus to each and every part regardless of who wrote it.

Thus, it is not the intent of this section to claim rights or contest your rights to work written entirely by you; rather, the intent is to exercise the right to control the distribution of derivative or collective works based on the Program. In addition, mere aggregation of another work not based on the Program with the Program (or with a work based on the Program) on a volume of a storage or distribution medium does not bring the other work under the scope of this License.

3. You may copy and distribute the Program (or a work based on it, under Section 2) in object code or executable form under the terms of Sections 1 and 2 above provided that you also do one of the following: a) Accompany it with the complete corresponding machine-readable source code, which must be distributed under the terms of Sections 1 and 2 above on a medium customarily used for software interchange; or, b) Accompany it with a written offer, valid for at least three years, to give any third party, for a charge no more than your cost of physically performing source distribution, a complete machine-readable copy of the corresponding source code, to be distributed under the terms of Sections 1 and 2 above on a medium customarily used for software interchange; or, c) Accompany it with the information you received as to the offer to distribute corresponding source code. (This

alternative is allowed only for noncommercial distribution and only if you received the program in object code or executable form with such an offer, in accord with Subsection b above.)

The source code for a work means the preferred form of the work for making modifications to it. For an executable work, complete source code means all the source code for all modules it contains, plus any associated interface definition files, plus the scripts used to control compilation and installation of the executable. However, as a special exception, the source code distributed need not include anything that is normally distributed (in either source or binary form) with the major components (compiler, kernel, and so on) of the operating system on which the executable runs, unless that component itself accompanies the executable.

If distribution of executable or object code is made by offering access to copy from a designated place, then offering equivalent access to copy the source code from the same place counts as distribution of the source code, even though third parties are not compelled to copy the source along with the object code.

4. You may not copy, modify, sublicense, or distribute the Program except as expressly provided under this License. Any attempt otherwise to copy, modify, sublicense or distribute the Program is void, and will automatically terminate your rights under this License. However, parties who have received copies, or rights, from you under this License will not have their licenses terminated so long as such parties remain in full compliance.

5. You are not required to accept this License, since you have not signed it. However, nothing else grants you permission to modify or distribute the Program or its derivative works. These actions are prohibited by law if you do not accept this License. Therefore, by modifying or distributing the Program (or any work based on the Program), you indicate your acceptance of this License to do so, and all its terms and conditions for copying, distributing or modifying the Program or works based on it.

6. Each time you redistribute the Program (or any work based on the Program), the recipient automatically receives a license from the original licensor to copy, distribute or modify the Program subject to these terms and conditions. You may not impose any further restrictions on the recipients' exercise of the rights granted herein. You are not responsible for enforcing compliance by third parties to this License.

6. Each time you redistribute the Program (or any work based on the Program), the recipient automatically receives a license from the original licensor to copy, distribute or modify the Program subject to these terms and conditions. You may not impose any further restrictions on the recipients' exercise of the rights granted herein. You are not responsible for enforcing compliance by third parties to this License.

7. If, as a consequence of a court judgment or allegation

of patent infringement or for any other reason (not limited to patent issues), conditions are imposed on you (whether by court order, agreement or otherwise) that contradict the conditions of this License, they do not excuse you from the conditions of this License.

If you cannot distribute so as to satisfy simultaneously your obligations under this License and any other pertinent obligations, then as a consequence you may not distribute the Program at all. For example, if a patent license would not permit royalty-free redistribution of the Program by all those who receive copies directly or indirectly through you, then the only way you could satisfy both it and this License would be to refrain entirely from distribution of the Program.

If any portion of this section is held invalid or unenforceable under any particular circumstance, the balance of the section is intended to apply and the section as a whole is intended to apply in other circumstances.

It is not the purpose of this section to induce you to infringe any patents or other property right claims or to contest validity of any such claims; this section has the sole purpose of protecting the integrity of the free software distribution system, which is implemented by public license practices. Many people have made generous contributions to the wide range of software distributed through that system in reliance on consistent application of that system; it is up to the author/donor to decide if he or she is willing to distribute software through any other system and a licensee cannot impose that choice.

This section is intended to make thoroughly clear what is believed to be a consequence of the rest of this License.

8. If the distribution and/or use of the Program is restricted in certain countries either by patents or by copyrighted interfaces, the original copyright holder who places the Program under this License may add an explicit geographical distribution limitation excluding those countries, so that distribution is permitted only in or among countries not thus excluded. In such case, this License incorporates the limitation as if written in the body of this License.

9. The Free Software Foundation may publish revised and/or new versions of the General Public License from time to time. Such new versions will be similar in spirit to the present version, but may differ in detail to address new problems or concerns.

Each version is given a distinguishing version number. If the Program specifies a version number of this License which applies to it and "any later version", you have the option of following the terms and conditions either of that version or of any later version published by the Free Software Foundation. If the Program does not specify a version number of this License, you may choose any version ever published by the Free Software Foundation.

10. If you wish to incorporate parts of the Program into other free programs whose distribution conditions are different, write to the author to ask for permission. For

software which is copyrighted by the Free Software Foundation, write to the Free Software Foundation; we sometimes make exceptions for this. Our decision will be guided by the two goals of preserving the free status of all derivatives of our free software and of promoting the sharing and reuse of software generally.

#### NO WARRANTY

11. BECAUSE THE PROGRAM IS LICENSED FREE OF CHARGE, THERE IS NO WARRANTY FOR THE PROGRAM, TO THE EXTENT PERMITTED BY APPLICABLE LAW. EXCEPT WHEN OTHERWISE STATED IN WRITING THE COPYRIGHT HOLDERS AND/OR OTHER PARTIES PROVIDE THE PROGRAM "AS IS" WITHOUT WARRANTY OF ANY KIND, EITHER EXPRESSED OR IMPLIED, INCLUDING, BUT NOT LIMITED TO, THE IMPLIED WARRANTIES OF MERCHANTABILITY AND FITNESS FOR A PARTICULAR PURPOSE. THE ENTIRE RISK AS TO THE QUALITY AND PERFORMANCE OF THE PROGRAM IS WITH YOU. SHOULD THE PROGRAM PROVE DEFECTIVE, YOU ASSUME THE COST OF ALL NECESSARY SERVICING, REPAIR OR CORRECTION.

12. IN NO EVENT UNLESS REQUIRED BY APPLICABLE LAW OR AGREED TO IN WRITING WILL ANY COPYRIGHT HOLDER, OR ANY OTHER PARTY WHO MAY MODIFY AND/OR REDISTRIBUTE THE PROGRAM AS PERMITTED ABOVE, BE LIABLE TO YOU FOR DAMAGES, INCLUDING ANY GENERAL, SPECIAL, INCIDENTAL OR CONSEQUENTIAL DAMAGES ARISING OUT OF THE USE OR INABILITY TO USE THE PROGRAM (INCLUDING BUT NOT LIMITED TO LOSS OF DATA OR DATA BEING RENDERED INACCURATE OR LOSSES SUSTAINED BY YOU OR THIRD PARTIES OR A FAILURE OF THE PROGRAM TO OPERATE WITH ANY OTHER PROGRAMS), EVEN IF SUCH HOLDER OR OTHER PARTY HAS BEEN ADVISED OF THE POSSIBILITY OF SUCH DAMAGES.

---

SQLite Copyright All of the deliverable code in SQLite has been dedicated to the public domain by the authors. All code authors, and representatives of the companies they work for, have signed affidavits dedicating their contributions to the public domain and originals of those signed affidavits are stored in a firesafe at the main offices of Hwaci. Anyone is free to copy, modify, publish, use, compile, sell, or distribute the original SQLite code, either in source code form or as a compiled binary, for any purpose, commercial or non-commercial, and by any means.

The previous paragraph applies to the deliverable code in SQLite - those parts of the SQLite library that you actually bundle and ship with a larger application. Portions of the documentation and some code used as part of the build process might fall under other licenses. The details here are unclear. We do not worry about the licensing of the documentation and build code so much

because none of these things are part of the core deliverable SQLite library.

All of the deliverable code in SQLite has been written from scratch. No code has been taken from other projects or from the open internet. Every line of code can be traced back to its original author, and all of those authors have public domain dedications on file. So the SQLite code base is clean and is uncontaminated with licensed code from other projects.

Obtaining An Explicit License To Use SQLite Even though SQLite is in the public domain and does not require a license, some users want to obtain a license anyway. Some reasons for obtaining a license include: You are using SQLite in a jurisdiction that does not recognize the public domain. You are using SQLite in a jurisdiction that does not recognize the right of an author to dedicate their work to the public domain. •You want to hold a tangible legal document as evidence that you have the legal right to use and distribute SQLite. •Your legal department tells you that you have to purchase a license. If you feel like you really have to purchase a license for SQLite, Hwaci, the company that employs the architect and principal developers of SQLite, will sell you one. Contributed Code In order to keep SQLite completely free and unencumbered by copyright, all new contributors to the SQLite code base are asked to dedicate their contributions to the public domain. If you want to send a patch or enhancement for possible inclusion in the SQLite source tree, please accompany the patch with the following statement:

The author or authors of this code dedicate any and all copyright interest in this code to the public domain. We make this dedication for the benefit of the public at large and to the detriment of our heirs and successors. We intend this dedication to be an overt act of relinquishment in perpetuity of all present and future rights to this code under copyright law.

We are not able to accept patches or changes to SQLite that are not accompanied by a statement such as the above. In addition, if you make changes or enhancements as an employee, then a simple statement such as the above is insufficient. You must also send by surface mail a copyright release signed by a company officer. A signed original of the copyright release should be mailed to:

Hwaci 6200 Maple Cove Lane Charlotte, NC 28269 USA

---

GNU GENERAL PUBLIC LICENSE Version 2, June 1991  
Copyright (C) 1989, 1991 Free Software Foundation, Inc.  
51 Franklin Street, Fifth Floor, Boston, MA 02110-1301, USA

Everyone is permitted to copy and distribute verbatim copies of this license document, but changing it is not allowed.

#### Preamble

The licenses for most software are designed to take away your freedom to share and change it. By contrast, the GNU General Public License is intended to guarantee

your freedom to share and change free software--to make sure the software is free for all its users. This General Public License applies to most of the Free Software Foundation's software and to any other program whose authors commit to using it. (Some other Free Software Foundation software is covered by the GNU Lesser General Public License instead.) You can apply it to your programs, too.

When we speak of free software, we are referring to freedom, not price. Our General Public Licenses are designed to make sure that you have the freedom to distribute copies of free software (and charge for this service if you wish), that you receive source code or can get it if you want it, that you can change the software or use pieces of it in new free programs; and that you know you can do these things.

To protect your rights, we need to make restrictions that forbid anyone to deny you these rights or to ask you to surrender the rights. These restrictions translate to certain responsibilities for you if you distribute copies of the software, or if you modify it.

For example, if you distribute copies of such a program, whether gratis or for a fee, you must give the recipients all the rights that you have. You must make sure that they, too, receive or can get the source code. And you must show them these terms so they know their rights. We protect your rights with two steps: (1) copyright the software, and (2) offer you this license which gives you legal permission to copy, distribute and/or modify the software.

Also, for each author's protection and ours, we want to make certain that everyone understands that there is no warranty for this free software. If the software is modified by someone else and passed on, we want its recipients to know that what they have is not the original, so that any problems introduced by others will not reflect on the original authors' reputations.

Finally, any free program is threatened constantly by software patents. We wish to avoid the danger that redistributors of a free program will individually obtain patent licenses, in effect making the program proprietary. To prevent this, we have made it clear that any patent must be licensed for everyone's free use or not licensed at all.

The precise terms and conditions for copying, distribution and modification follow.

**TERMS AND CONDITIONS FOR COPYING, DISTRIBUTION AND MODIFICATION 0.** This License applies to any program or other work which contains a notice placed by the copyright holder saying it may be distributed under the terms of this General Public License. The "Program", below, refers to any such program or work, and a "work based on the Program" means either the Program or any derivative work under copyright law: that is to say, a work containing the Program or a portion of it, either verbatim or with modifications and/or translated into another language. (Hereinafter, translation is included without limitation in

the term "modification".) Each licensee is addressed as "you".

Activities other than copying, distribution and modification are not covered by this License; they are outside its scope. The act of running the Program is not restricted, and the output from the Program is covered only if its contents constitute a work based on the Program (independent of having been made by running the Program). Whether that is true depends on what the Program does.

1. You may copy and distribute verbatim copies of the Program's source code as you receive it, in any medium, provided that you conspicuously and appropriately publish on each copy an appropriate copyright notice and disclaimer of warranty; keep intact all the notices that refer to this License and to the absence of any warranty; and give any other recipients of the Program a copy of this License along with the Program.

You may charge a fee for the physical act of transferring a copy, and you may at your option offer warranty protection in exchange for a fee.

2. You may modify your copy or copies of the Program or any portion of it, thus forming a work based on the Program, and copy and distribute such modifications or work under the terms of Section 1 above, provided that you also meet all of these conditions: a) You must cause the modified files to carry prominent notices stating that you changed the files and the date of any change. b) You must cause any work that you distribute or publish, that in whole or in part contains or is derived from the Program or any part thereof, to be licensed as a whole at no charge to all third parties under the terms of this License. c) If the modified program normally reads commands interactively when run, you must cause it, when started running for such interactive use in the most ordinary way, to print or display an announcement including an appropriate copyright notice and a notice that there is no warranty (or else, saying that you provide a warranty) and that users may redistribute the program under these conditions, and telling the user how to view a copy of this License. (Exception: if the Program itself is interactive but does not normally print such an announcement, your work based on the Program is not required to print an announcement.)

These requirements apply to the modified work as a whole. If identifiable sections of that work are not derived from the Program, and can be reasonably considered independent and separate works in themselves, then this License, and its terms, do not apply to those sections when you distribute them as separate works. But when you distribute the same sections as part of a whole which is a work based on the Program, the distribution of the whole must be on the terms of this License, whose permissions for other licensees extend to the entire whole, and thus to each and every part regardless of who wrote it.

Thus, it is not the intent of this section to claim rights or contest your rights to work written entirely by you; rather,

the intent is to exercise the right to control the distribution of derivative or collective works based on the Program. In addition, mere aggregation of another work not based on the Program with the Program (or with a work based on the Program) on a volume of a storage or distribution medium does not bring the other work under the scope of this License.

3. You may copy and distribute the Program (or a work based on it, under Section 2) in object code or executable form under the terms of Sections 1 and 2 above provided that you also do one of the following: a) Accompany it with the complete corresponding machine-readable source code, which must be distributed under the terms of Sections 1 and 2 above on a medium customarily used for software interchange; or, b) Accompany it with a written offer, valid for at least three years, to give any third party, for a charge no more than your cost of physically performing source distribution, a complete machine-readable copy of the corresponding source code, to be distributed under the terms of Sections 1 and 2 above on a medium customarily used for software interchange; or, c) Accompany it with the information you received as to the offer to distribute corresponding source code. (This alternative is allowed only for non-commercial distribution and only if you received the program in object code or executable form with such an offer, in accord with Subsection b above.) The source code for a work means the preferred form of the work for making modifications to it. For an executable work, complete source code means all the source code for all modules it contains, plus any associated interface definition files, plus the scripts used to control compilation and installation of the executable. However, as a special exception, the source code distributed need not include anything that is normally distributed (in either source or binary form) with the major components (compiler, kernel, and so on) of the operating system on which the executable runs, unless that component itself accompanies the executable.

If distribution of executable or object code is made by offering access to copy from a designated place, then offering equivalent access to copy the source code from the same place counts as distribution of the source code, even though third parties are not compelled to copy the source along with the object code.

4. You may not copy, modify, sublicense, or distribute the Program except as expressly provided under this License. Any attempt otherwise to copy, modify, sublicense or distribute the Program is void, and will automatically terminate your rights under this License. However, parties who have received copies, or rights, from you under this License will not have their licenses terminated so long as such parties remain in full compliance.

5. You are not required to accept this License, since you have not signed it. However, nothing else grants you permission to modify or distribute the Program or its derivative works. These actions are prohibited by law if

you do not accept this License. Therefore, by modifying or distributing the Program (or any work based on the Program), you indicate your acceptance of this License to do so, and all its terms and conditions for copying, distributing or modifying the Program or works based on it.

6. Each time you redistribute the Program (or any work based on the Program), the recipient automatically receives a license from the original licensor to copy, distribute or modify the Program subject to these terms and conditions. You may not impose any further restrictions on the recipients' exercise of the rights granted herein. You are not responsible for enforcing compliance by third parties to this License.

7. If, as a consequence of a court judgment or allegation of patent infringement or for any other reason (not limited to patent issues), conditions are imposed on you (whether by court order, agreement or otherwise) that contradict the conditions of this License, they do not excuse you from the conditions of this License. If you cannot distribute so as to satisfy simultaneously your obligations under this License and any other pertinent obligations, then as a consequence you may not distribute the Program at all. For example, if a patent license would not permit royalty-free redistribution of the Program by all those who receive copies directly or indirectly through you, then the only way you could satisfy both it and this License would be to refrain entirely from distribution of the Program.

If any portion of this section is held invalid or unenforceable under any particular circumstance, the balance of the section is intended to apply and the section as a whole is intended to apply in other circumstances.

It is not the purpose of this section to induce you to infringe any patents or other property right claims or to contest validity of any such claims; this section has the sole purpose of protecting the integrity of the free software distribution system, which is implemented by public license practices. Many people have made generous contributions to the wide range of software distributed through that system in reliance on consistent application of that system; it is up to the author/donor to decide if he or she is willing to distribute software through any other system and a licensee cannot impose that choice.

This section is intended to make thoroughly clear what is believed to be a consequence of the rest of this License.

8. If the distribution and/or use of the Program is restricted in certain countries either by patents or by copyrighted interfaces, the original copyright holder who places the Program under this License may add an explicit geographical distribution limitation excluding those countries, so that distribution is permitted only in or among countries not thus excluded. In such case, this License incorporates the limitation as if written in the body of this License.

9. The Free Software Foundation may publish revised

and/or new versions of the General Public License from time to time. Such new versions will be similar in spirit to the present version, but may differ in detail to address new problems or concerns.

Each version is given a distinguishing version number. If the Program specifies a version number of this License which applies to it and "any later version", you have the option of following the terms and conditions either of that version or of any later version published by the Free Software Foundation.

If the Program does not specify a version number of this License, you may choose any version ever published by the Free Software Foundation.

10. If you wish to incorporate parts of the Program into other free programs whose distribution conditions are different, write to the author to ask for permission. For software which is copyrighted by the Free Software Foundation, write to the Free Software Foundation; we sometimes make exceptions for this. Our decision will be guided by the two goals of preserving the free status of all derivatives of our free software and of promoting the sharing and reuse of software generally.

#### NO WARRANTY

11. BECAUSE THE PROGRAM IS LICENSED FREE OF CHARGE, THERE IS NO WARRANTY FOR THE PROGRAM, TO THE EXTENT PERMITTED BY APPLICABLE LAW. EXCEPT WHEN OTHERWISE STATED IN WRITING THE COPYRIGHT HOLDERS AND/OR OTHER PARTIES PROVIDE THE PROGRAM "AS IS" WITHOUT WARRANTY OF ANY KIND, EITHER EXPRESSED OR IMPLIED, INCLUDING, BUT NOT LIMITED TO, THE IMPLIED WARRANTIES OF MERCHANTABILITY AND FITNESS FOR A PARTICULAR PURPOSE. THE ENTIRE RISK AS TO THE QUALITY AND PERFORMANCE OF THE PROGRAM IS WITH YOU. SHOULD THE PROGRAM PROVE DEFECTIVE, YOU ASSUME THE COST OF ALL NECESSARY SERVICING, REPAIR OR CORRECTION.

12. IN NO EVENT UNLESS REQUIRED BY APPLICABLE LAW OR AGREED TO IN WRITING WILL ANY COPYRIGHT HOLDER, OR ANY OTHER PARTY WHO MAY MODIFY AND/OR REDISTRIBUTE THE PROGRAM AS PERMITTED ABOVE, BE LIABLE TO YOU FOR DAMAGES, INCLUDING ANY GENERAL, SPECIAL, INCIDENTAL OR CONSEQUENTIAL DAMAGES ARISING OUT OF THE USE OR INABILITY TO USE THE PROGRAM (INCLUDING BUT NOT LIMITED TO LOSS OF DATA OR DATA BEING RENDERED INACCURATE OR LOSSES SUSTAINED BY YOU OR THIRD PARTIES OR A FAILURE OF THE PROGRAM TO OPERATE WITH ANY OTHER PROGRAMS), EVEN IF SUCH HOLDER OR OTHER PARTY HAS BEEN ADVISED OF THE POSSIBILITY OF SUCH DAMAGES.

END OF TERMS AND CONDITIONS

---

GNU GENERAL PUBLIC LICENSE Version 3, 29 June

2007

Copyright © 2007 Free Software Foundation, Inc.

<http://fsf.org/>

Everyone is permitted to copy and distribute verbatim copies of this license document, but changing it is not allowed.

#### Preamble

The GNU General Public License is a free, copyleft license for software and other kinds of works.

The licenses for most software and other practical works are designed to take away your freedom to share and change the works. By contrast, the GNU General Public License is intended to guarantee your freedom to share and change all versions of a program--to make sure it remains free software for all its users. We, the Free Software Foundation, use the GNU General Public License for most of our software; it applies also to any other work released this way by its authors. You can apply it to your programs, too.

When we speak of free software, we are referring to freedom, not price. Our General Public Licenses are designed to make sure that you have the freedom to distribute copies of free software (and charge for them if you wish), that you receive source code or can get it if you want it, that you can change the software or use pieces of it in new free programs, and that you know you can do these things.

To protect your rights, we need to prevent others from denying you these rights or asking you to surrender the rights. Therefore, you have certain responsibilities if you distribute copies of the software, or if you modify it: responsibilities to respect the freedom of others.

For example, if you distribute copies of such a program, whether gratis or for a fee, you must pass on to the recipients the same freedoms that you received. You must make sure that they, too, receive or can get the source code. And you must show them these terms so they know their rights.

Developers that use the GNU GPL protect your rights with two steps: (1) assert copyright on the software, and (2) offer you this License giving you legal permission to copy, distribute and/or modify it.

For example, if you distribute copies of such a program, whether gratis or for a fee, you must pass on to the recipients the same freedoms that you received. You must make sure that they, too, receive or can get the source code. And you must show them these terms so they know their rights.

Developers that use the GNU GPL protect your rights with two steps: (1) assert copyright on the software, and (2) offer you this License giving you legal permission to copy, distribute and/or modify it.

Finally, every program is threatened constantly by software patents. States should not allow patents to restrict development and use of software on general-purpose computers, but in those that do, we wish to avoid the special danger that patents applied to a free program could make it effectively proprietary. To prevent

this, the GPL assures that patents cannot be used to render the program non-free.

The precise terms and conditions for copying, distribution and modification follow.

## TERMS AND CONDITIONS

0. Definitions. "This License" refers to version 3 of the GNU General Public License. "Copyright" also means copyright-like laws that apply to other kinds of works, such as semiconductor masks. "The Program" refers to any copyrightable work licensed under this License. Each licensee is addressed as "you". "Licensees" and "recipients" may be individuals or organizations. To "modify" a work means to copy from or adapt all or part of the work in a fashion requiring copyright permission, other than the making of an exact copy. The resulting work is called a "modified version" of the earlier work or a work "based on" the earlier work.

A "covered work" means either the unmodified Program or a work based on the Program.

To "propagate" a work means to do anything with it that, without permission, would make you directly or secondarily liable for infringement under applicable copyright law, except executing it on a computer or modifying a private copy. Propagation includes copying, distribution (with or without modification), making available to the public, and in some countries other activities as well.

To "convey" a work means any kind of propagation that enables other parties to make or receive copies. Mere interaction with a user through a computer network, with no transfer of a copy, is not conveying.

An interactive user interface displays "Appropriate Legal Notices" to the extent that it includes a convenient and prominently visible feature that (1) displays an appropriate copyright notice, and (2) tells the user that there is no warranty for the work (except to the extent that warranties are provided), that licensees may convey the work under this License, and how to view a copy of this License. If the interface presents a list of user commands or options, such as a menu, a prominent item in the list meets this criterion.

### 1. Source Code.

The "source code" for a work means the preferred form of the work for making modifications to it. "Object code" means any non-source form of a work.

A "Standard Interface" means an interface that either is an official standard defined by a recognized standards body, or, in the case of interfaces specified for a particular programming language, one that is widely used among developers working in that language.

The "System Libraries" of an executable work include anything, other than the work as a whole, that (a) is included in the normal form of packaging a Major Component, but which is not part of that Major Component, and (b) serves only to enable use of the work with that Major Component, or to implement a Standard Interface for which an implementation is available to the public in source code form. A "Major

Component", in this context, means a major essential component (kernel, window system, and so on) of the specific operating system (if any) on which the executable work runs, or a compiler used to produce the work, or an object code interpreter used to run it.

The "Corresponding Source" for a work in object code form means all the source code needed to generate, install, and (for an executable work) run the object code and to modify the work, including scripts to control those activities. However, it does not include the work's System Libraries, or general-purpose tools or generally available free programs which are used unmodified in performing those activities but which are not part of the work. For example, Corresponding Source includes interface definition files associated with source files for the work, and the source code for shared libraries and dynamically linked subprograms that the work is specifically designed to require, such as by intimate data communication or control flow between those subprograms and other parts of the work.

The Corresponding Source need not include anything that users can regenerate automatically from other parts of the Corresponding Source.

The Corresponding Source for a work in source code form is that same work.

### 2. Basic Permissions.

All rights granted under this License are granted for the term of copyright on the Program, and are irrevocable provided the stated conditions are met. This License explicitly affirms your unlimited permission to run the unmodified Program. The output from running a covered work is covered by this License only if the output, given its content, constitutes a covered work. This License acknowledges your rights of fair use or other equivalent, as provided by copyright law.

You may make, run and propagate covered works that you do not convey, without conditions so long as your license otherwise remains in force. You may convey covered works to others for the sole purpose of having them make modifications exclusively for you, or provide you with facilities for running those works, provided that you comply with the terms of this License in conveying all material for which you do not control copyright. Those thus making or running the covered works for you must do so exclusively on your behalf, under your direction and control, on terms that prohibit them from making any copies of your copyrighted material outside their relationship with you. Conveying under any other circumstances is permitted solely under the conditions stated below. Sublicensing is not allowed; section 10 makes it unnecessary.

### 3. Protecting Users' Legal Rights From Anti-Circumvention Law.

No covered work shall be deemed part of an effective technological measure under any applicable law fulfilling obligations under article 11 of the WIPO copyright treaty adopted on 20 December 1996, or similar laws prohibiting or restricting circumvention of such measures.

When you convey a covered work, you waive any legal power to forbid circumvention of technological measures to the extent such circumvention is effected by exercising rights under this License with respect to the covered work, and you disclaim any intention to limit operation or modification of the work as a means of enforcing, against the work's users, your or third parties' legal rights to forbid circumvention of technological measures.

#### 4. Conveying Verbatim Copies.

You may convey verbatim copies of the Program's source code as you receive it, in any medium, provided that you conspicuously and appropriately publish on each copy an appropriate copyright notice; keep intact all notices stating that this License and any non-permissive terms added in accord with section 7 apply to the code; keep intact all notices of the absence of any warranty; and give all recipients a copy of this License along with the Program.

You may charge any price or no price for each copy that you convey, and you may offer support or warranty protection for a fee.

#### 5. Conveying Modified Source Versions.

You may convey a work based on the Program, or the modifications to produce it from the Program, in the form of source code under the terms of section 4, provided that you also meet all of these conditions: •a) The work must carry prominent notices stating that you modified it, and giving a relevant date. •b) The work must carry prominent notices stating that it is released under this License and any conditions added under section 7. This requirement modifies the requirement in section 4 to "keep intact all notices".

c) You must license the entire work, as a whole, under this License to anyone who comes into possession of a copy. This License will therefore apply, along with any applicable section 7 additional terms, to the whole of the work, and all its parts, regardless of how they are packaged. This License gives no permission to license the work in any other way, but it does not invalidate such permission if you have separately received it. •d) If the work has interactive user interfaces, each must display Appropriate Legal Notices; however, if the Program has interactive interfaces that do not display Appropriate Legal Notices, your work need not make them do so.

A compilation of a covered work with other separate and independent works, which are not by their nature extensions of the covered work, and which are not combined with it such as to form a larger program, in or on a volume of a storage or distribution medium, is called an "aggregate" if the compilation and its resulting copyright are not used to limit the access or legal rights of the compilation's users beyond what the individual works permit. Inclusion of a covered work in an aggregate does not cause this License to apply to the other parts of the aggregate.

#### 6. Conveying Non-Source Forms.

You may convey a covered work in object code form under the terms of sections 4 and 5, provided that you

also convey the machine-readable Corresponding Source under the terms of this License, in one of these ways: a) Convey the object code in, or embodied in, a physical product (including a physical distribution medium), accompanied by the Corresponding Source fixed on a durable physical medium customarily used for software interchange. b) Convey the object code in, or embodied in, a physical product (including a physical distribution medium), accompanied by a written offer, valid for at least three years and valid for as long as you offer spare parts or customer support for that product model, to give anyone who possesses the object code either (1) a copy of the Corresponding Source for all the software in the product that is covered by this License, on a durable physical medium customarily used for software interchange, for a price no more than your reasonable cost of physically performing this conveying of source, or (2) access to copy the Corresponding Source from a network server at no charge. c) Convey individual copies of the object code with a copy of the written offer to provide the Corresponding Source. This alternative is allowed only occasionally and noncommercially, and only if you received the object code with such an offer, in accord with subsection 6b. d) Convey the object code by offering access from a designated place (gratis or for a charge), and offer equivalent access to the Corresponding Source in the same way through the same place at no further charge. You need not require recipients to copy the Corresponding Source along with the object code. If the place to copy the object code is a network server, the Corresponding Source may be on a different server (operated by you or a third party) that supports equivalent copying facilities, provided you maintain clear directions next to the object code saying where to find the Corresponding Source. Regardless of what server hosts the Corresponding Source, you remain obligated to ensure that it is available for as long as needed to satisfy these requirements. e) Convey the object code using peer-to-peer transmission, provided you inform other peers where the object code and Corresponding Source of the work are being offered to the general public at no charge under subsection 6d. A separable portion of the object code, whose source code is excluded from the Corresponding Source as a System Library, need not be included in conveying the object code work.

A "User Product" is either (1) a "consumer product", which means any tangible personal property which is normally used for personal, family, or household purposes, or (2) anything designed or sold for incorporation into a dwelling. In determining whether a product is a consumer product, doubtful cases shall be resolved in favor of coverage. For a particular product received by a particular user, "normally used" refers to a typical or common use of that class of product, regardless of the status of the particular user or of the way in which the particular user actually uses, or expects or is expected to use, the product. A product is a



consumer product regardless of whether the product has substantial commercial, industrial or non-consumer uses, unless such uses represent the only significant mode of use of the product.

“Installation Information” for a User Product means any methods, procedures, authorization keys, or other information required to install and execute modified versions of a covered work in that User Product from a modified version of its Corresponding Source. The information must suffice to ensure that the continued functioning of the modified object code is in no case prevented or interfered with solely because modification has been made.

If you convey an object code work under this section in, or with, or specifically for use in, a User Product, and the conveying occurs as part of a transaction in which the right of possession and use of the User Product is transferred to the recipient in perpetuity or for a fixed term (regardless of how the transaction is characterized), the Corresponding Source conveyed under this section must be accompanied by the Installation Information. But this requirement does not apply if neither you nor any third party retains the ability to install modified object code on the User Product (for example, the work has been installed in ROM).

The requirement to provide Installation Information does not include a requirement to continue to provide support service, warranty, or updates for a work that has been modified or installed by the recipient, or for the User Product in which it has been modified or installed. Access to a network may be denied when the modification itself materially and adversely affects the operation of the network or violates the rules and protocols for communication across the network.

Corresponding Source conveyed, and Installation Information provided, in accord with this section must be in a format that is publicly documented (and with an implementation available to the public in source code form), and must require no special password or key for unpacking, reading or copying.

#### 7. Additional Terms.

“Additional permissions” are terms that supplement the terms of this License by making exceptions from one or more of its conditions. Additional permissions that are applicable to the entire Program shall be treated as though they were included in this License, to the extent that they are valid under applicable law. If additional permissions apply only to part of the Program, that part may be used separately under those permissions, but the entire Program remains governed by this License without regard to the additional permissions.

When you convey a copy of a covered work, you may at your option remove any additional permissions from that copy, or from any part of it. (Additional permissions may be written to require their own removal in certain cases when you modify the work.) You may place additional permissions on material, added by you to a covered work, for which you have or can give appropriate

copyright permission.

Notwithstanding any other provision of this License, for material you add to a covered work, you may (if authorized by the copyright holders of that material) supplement the terms of this License with terms:

- a) Disclaiming warranty or limiting liability differently from the terms of sections 15 and 16 of this License; or
- b) Requiring preservation of specified reasonable legal notices or author attributions in that material or in the Appropriate Legal Notices displayed by works containing it; or
- c) Prohibiting misrepresentation of the origin of that material, or requiring that modified versions of such material be marked in reasonable ways as different from the original version; or
- d) Limiting the use for publicity purposes of names of licensors or authors of the material; or
- e) Declining to grant rights under trademark law for use of some trade names, trademarks, or service marks; or
- f) Requiring indemnification of licensors and authors of that material by anyone who conveys the material (or modified versions of it) with contractual assumptions of liability to the recipient, for any liability that these contractual assumptions directly impose on those licensors and authors.

All other non-permissive additional terms are considered “further restrictions” within the meaning of section 10. If the Program as you received it, or any part of it, contains a notice stating that it is governed by this License along with a term that is a further restriction, you may remove that term. If a license document contains a further restriction but permits relicensing or conveying under this License, you may add to a covered work material governed by the terms of that license document, provided that the further restriction does not survive such relicensing or conveying.

If you add terms to a covered work in accord with this section, you must place, in the relevant source files, a statement of the additional terms that apply to those files, or a notice indicating where to find the applicable terms. Additional terms, permissive or non-permissive, may be stated in the form of a separately written license, or stated as exceptions; the above requirements apply either way.

#### 8. Termination.

You may not propagate or modify a covered work except as expressly provided under this License. Any attempt otherwise to propagate or modify it is void, and will automatically terminate your rights under this License (including any patent licenses granted under the third paragraph of section 11).

However, if you cease all violation of this License, then your license from a particular copyright holder is reinstated (a) provisionally, unless and until the copyright holder explicitly and finally terminates your license, and (b) permanently, if the copyright holder fails to notify you of the violation by some reasonable means prior to 60 days after the cessation.

Moreover, your license from a particular copyright holder is reinstated permanently if the copyright holder notifies

you of the violation by some reasonable means, this is the first time you have received notice of violation of this License (for any work) from that copyright holder, and you cure the violation prior to 30 days after your receipt of the notice.

Termination of your rights under this section does not terminate the licenses of parties who have received copies or rights from you under this License. If your rights have been terminated and not permanently reinstated, you do not qualify to receive new licenses for the same material under section 10.

#### 9. Acceptance Not Required for Having Copies.

You are not required to accept this License in order to receive or run a copy of the Program. Ancillary propagation of a covered work occurring solely as a consequence of using peer-to-peer transmission to receive a copy likewise does not require acceptance. However, nothing other than this License grants you permission to propagate or modify any covered work. These actions infringe copyright if you do not accept this License. Therefore, by modifying or propagating a covered work, you indicate your acceptance of this License to do so.

#### 10. Automatic Licensing of Downstream Recipients.

Each time you convey a covered work, the recipient automatically receives a license from the original licensors, to run, modify and propagate that work, subject to this License. You are not responsible for enforcing compliance by third parties with this License.

An “entity transaction” is a transaction transferring control of an organization, or substantially all assets of one, or subdividing an organization, or merging organizations. If propagation of a covered work results from an entity transaction, each party to that transaction who receives a copy of the work also receives whatever licenses to the work the party's predecessor in interest had or could give under the previous paragraph, plus a right to possession of the Corresponding Source of the work from the predecessor in interest, if the predecessor has it or can get it with reasonable efforts.

You may not impose any further restrictions on the exercise of the rights granted or affirmed under this License. For example, you may not impose a license fee, royalty, or other charge for exercise of rights granted under this License, and you may not initiate litigation (including a cross-claim or counterclaim in a lawsuit) alleging that any patent claim is infringed by making, using, selling, offering for sale, or importing the Program or any portion of it.

#### 11. Patents.

A “contributor” is a copyright holder who authorizes use under this License of the Program or a work on which the Program is based. The work thus licensed is called the contributor's “contributor version”. A contributor's “essential patent claims” are all patent claims owned or controlled by the contributor, whether already acquired or hereafter acquired, that would be infringed by some manner, permitted by this License, of making, using, or

selling its contributor version, but do not include claims that would be infringed only as a consequence of further modification of the contributor version. For purposes of this definition, “control” includes the right to grant patent sublicenses in a manner consistent with the requirements of this License.

Each contributor grants you a non-exclusive, worldwide, royalty-free patent license under the contributor's essential patent claims, to make, use, sell, offer for sale, import and otherwise run, modify and propagate the contents of its contributor version.

In the following three paragraphs, a “patent license” is any express agreement or commitment, however denominated, not to enforce a patent (such as an express permission to practice a patent or covenant not to sue for patent infringement). To “grant” such a patent license to a party means to make such an agreement or commitment not to enforce a patent against the party. If you convey a covered work, knowingly relying on a patent license, and the Corresponding Source of the work is not available for anyone to copy, free of charge and under the terms of this License, through a publicly available network server or other readily accessible means, then you must either (1) cause the Corresponding Source to be so available, or (2) arrange to deprive yourself of the benefit of the patent license for this particular work, or (3) arrange, in a manner consistent with the requirements of this License, to extend the patent license to downstream recipients. “Knowingly relying” means you have actual knowledge that, but for the patent license, your conveying the covered work in a country, or your recipient's use of the covered work in a country, would infringe one or more identifiable patents in that country that you have reason to believe are valid.

If, pursuant to or in connection with a single transaction or arrangement, you convey, or propagate by procuring conveyance of, a covered work, and grant a patent license to some of the parties receiving the covered work authorizing them to use, propagate, modify or convey a specific copy of the covered work, then the patent license you grant is automatically extended to all recipients of the covered work and works based on it.

A patent license is “discriminatory” if it does not include within the scope of its coverage, prohibits the exercise of, or is conditioned on the non-exercise of one or more of the rights that are specifically granted under this License. You may not convey a covered work if you are a party to an arrangement with a third party that is in the business of distributing software, under which you make payment to the third party based on the extent of your activity of conveying the work, and under which the third party grants, to any of the parties who would receive the covered work from you, a discriminatory patent license (a) in connection with copies of the covered work conveyed by you (or copies made from those copies), or (b) primarily for and in connection with specific products or compilations that contain the covered work, unless you

entered into that arrangement, or that patent license was granted, prior to 28 March 2007. Nothing in this License shall be construed as excluding or limiting any implied license or other defenses to infringement that may otherwise be available to you under applicable patent law.

#### 12. No Surrender of Others' Freedom.

If conditions are imposed on you (whether by court order, agreement or otherwise) that contradict the conditions of this License, they do not excuse you from the conditions of this License. If you cannot convey a covered work so as to satisfy simultaneously your obligations under this License and any other pertinent obligations, then as a consequence you may not convey it at all. For example, if you agree to terms that obligate you to collect a royalty for further conveying from those to whom you convey the Program, the only way you could satisfy both those terms and this License would be to refrain entirely from conveying the Program.

#### 13. Use with the GNU Affero General Public License.

Notwithstanding any other provision of this License, you have permission to link or combine any covered work with a work licensed under version 3 of the GNU Affero General Public License into a single combined work, and to convey the resulting work. The terms of this License will continue to apply to the part which is the covered work, but the special requirements of the GNU Affero General Public License, section 13, concerning interaction through a network will apply to the combination as such.

#### 14. Revised Versions of this License.

The Free Software Foundation may publish revised and/or new versions of the GNU General Public License from time to time. Such new versions will be similar in spirit to the present version, but may differ in detail to address new problems or concerns.

Each version is given a distinguishing version number. If the Program specifies that a certain numbered version of the GNU General Public License "or any later version" applies to it, you have the option of following the terms and conditions either of that numbered version or of any later version published by the Free Software Foundation. If the Program does not specify a version number of the GNU General Public License, you may choose any version ever published by the Free Software Foundation. If the Program specifies that a proxy can decide which future versions of the GNU General Public License can be used, that proxy's public statement of acceptance of a version permanently authorizes you to choose that version for the Program.

Later license versions may give you additional or different permissions. However, no additional obligations are imposed on any author or copyright holder as a result of your choosing to follow a later version.

#### 15. Disclaimer of Warranty.

THERE IS NO WARRANTY FOR THE PROGRAM, TO THE EXTENT PERMITTED BY APPLICABLE LAW. EXCEPT WHEN OTHERWISE STATED IN WRITING

THE COPYRIGHT HOLDERS AND/OR OTHER PARTIES PROVIDE THE PROGRAM "AS IS" WITHOUT WARRANTY OF ANY KIND, EITHER EXPRESSED OR IMPLIED, INCLUDING, BUT NOT LIMITED TO, THE IMPLIED WARRANTIES OF MERCHANTABILITY AND FITNESS FOR A PARTICULAR PURPOSE. THE ENTIRE RISK AS TO THE QUALITY AND PERFORMANCE OF THE PROGRAM IS WITH YOU. SHOULD THE PROGRAM PROVE DEFECTIVE, YOU ASSUME THE COST OF ALL NECESSARY SERVICING, REPAIR OR CORRECTION.

#### 16. Limitation of Liability.

IN NO EVENT UNLESS REQUIRED BY APPLICABLE LAW OR AGREED TO IN WRITING WILL ANY COPYRIGHT HOLDER, OR ANY OTHER PARTY WHO MODIFIES AND/OR CONVEYS THE PROGRAM AS PERMITTED ABOVE, BE LIABLE TO YOU FOR DAMAGES, INCLUDING ANY GENERAL, SPECIAL, INCIDENTAL OR CONSEQUENTIAL DAMAGES ARISING OUT OF THE USE OR INABILITY TO USE THE PROGRAM (INCLUDING BUT NOT LIMITED TO LOSS OF DATA OR DATA BEING RENDERED INACCURATE OR LOSSES SUSTAINED BY YOU OR THIRD PARTIES OR A FAILURE OF THE PROGRAM TO OPERATE WITH ANY OTHER PROGRAMS), EVEN IF SUCH HOLDER OR OTHER PARTY HAS BEEN ADVISED OF THE POSSIBILITY OF SUCH DAMAGES.

#### 17. Interpretation of Sections 15 and 16.

If the disclaimer of warranty and limitation of liability provided above cannot be given local legal effect according to their terms, reviewing courts shall apply local law that most closely approximates an absolute waiver of all civil liability in connection with the Program, unless a warranty or assumption of liability accompanies a copy of the Program in return for a fee.

END OF TERMS AND CONDITIONS

---

GNU LESSER GENERAL PUBLIC LICENSE Version 2.1, February 1999

Copyright (C) 1991, 1999 Free Software Foundation, Inc. 51 Franklin Street, Fifth Floor, Boston, MA 02110-1301 USA Everyone is permitted to copy and distribute verbatim copies of this license document, but changing it is not allowed.

[This is the first released version of the Lesser GPL. It also counts as the successor of the GNU Library Public License, version 2, hence the version number 2.1.]

#### Preamble

The licenses for most software are designed to take away your freedom to share and change it. By contrast, the GNU General Public Licenses are intended to guarantee your freedom to share and change free software--to make sure the software is free for all its users.

This license, the Lesser General Public License, applies to some specially designated software packages--typically libraries--of the Free Software Foundation and other authors who decide to use it. You

can use it too, but we suggest you first think carefully about whether this license or the ordinary General Public License is the better strategy to use in any particular case, based on the explanations below.

When we speak of free software, we are referring to freedom of use, not price. Our General Public Licenses are designed to make sure that you have the freedom to distribute copies of free software (and charge for this service if you wish); that you receive source code or can get it if you want it; that you can change the software and use pieces of it in new free programs; and that you are informed that you can do these things.

To protect your rights, we need to make restrictions that forbid distributors to deny you these rights or to ask you to surrender these rights. These restrictions translate to certain responsibilities for you if you distribute copies of the library or if you modify it. For example, if you distribute copies of the library, whether gratis or for a fee, you must give the recipients all the rights that we gave you. You must make sure that they, too, receive or can get the source code. If you link other code with the library, you must provide complete object files to the recipients, so that they can relink them with the library after making changes to the library and recompiling it. And you must show them these terms so they know their rights.

We protect your rights with a two-step method: (1) we copyright the library, and (2) we offer you this license, which gives you legal permission to copy, distribute and/or modify the library.

To protect each distributor, we want to make it very clear that there is no warranty for the free library. Also, if the library is modified by someone else and passed on, the recipients should know that what they have is not the original version, so that the original author's reputation will not be affected by problems that might be introduced by others.

Finally, software patents pose a constant threat to the existence of any free program. We wish to make sure that a company cannot effectively restrict the users of a free program by obtaining a restrictive license from a patent holder. Therefore, we insist that any patent license obtained for a version of the library must be consistent with the full freedom of use specified in this license.

Most GNU software, including some libraries, is covered by the ordinary GNU General Public License. This license, the GNU Lesser General Public License, applies to certain designated libraries, and is quite different from the ordinary General Public License. We use this license for certain libraries in order to permit linking those libraries into non-free programs.

When a program is linked with a library, whether statically or using a shared library, the combination of the two is legally speaking a combined work, a derivative of the original library. The ordinary General Public License therefore permits such linking only if the entire combination fits its criteria of freedom. The Lesser General Public License permits more lax criteria for

linking other code with the library.

We call this license the "Lesser" General Public License because it does Less to protect the user's freedom than the ordinary General Public License. It also provides other free software developers Less of an advantage over competing non-free programs. These disadvantages are the reason we use the ordinary General Public License for many libraries. However, the Lesser license provides advantages in certain special circumstances. For example, on rare occasions, there may be a special need to encourage the widest possible use of a certain library, so that it becomes a de-facto standard. To achieve this, non-free programs must be allowed to use the library. A more frequent case is that a free library does the same job as widely used non-free libraries. In this case, there is little to gain by limiting the free library to free software only, so we use the Lesser General Public License.

In other cases, permission to use a particular library in non-free programs enables a greater number of people to use a large body of free software. For example, permission to use the GNU C Library in non-free programs enables many more people to use the whole GNU operating system, as well as its variant, the GNU/Linux operating system.

Although the Lesser General Public License is Less protective of the users' freedom, it does ensure that the user of a program that is linked with the Library has the freedom and the wherewithal to run that program using a modified version of the Library.

The precise terms and conditions for copying, distribution and modification follow. Pay close attention to the difference between a "work based on the library" and a "work that uses the library". The former contains code derived from the library, whereas the latter must be combined with the library in order to run.

#### TERMS AND CONDITIONS FOR COPYING, DISTRIBUTION AND MODIFICATION

0. This License Agreement applies to any software library or other program which contains a notice placed by the copyright holder or other authorized party saying it may be distributed under the terms of this Lesser General Public License (also called "this License"). Each licensee is addressed as "you".

A "library" means a collection of software functions and/or data prepared so as to be conveniently linked with application programs (which use some of those functions and data) to form executables.

The "Library", below, refers to any such software library or work which has been distributed under these terms. A "work based on the Library" means either the Library or any derivative work under copyright law: that is to say, a work containing the Library or a portion of it, either verbatim or with modifications and/or translated straightforwardly into another language. (Hereinafter, translation is included without limitation in the term "modification".)

"Source code" for a work means the preferred form of the

work for making modifications to it. For a library, complete source code means all the source code for all modules it contains, plus any associated interface definition files, plus the scripts used to control compilation and installation of the library.

"Source code" for a work means the preferred form of the work for making modifications to it. For a library, complete source code means all the source code for all modules it contains, plus any associated interface definition files, plus the scripts used to control compilation and installation of the library.

1. You may copy and distribute verbatim copies of the Library's complete source code as you receive it, in any medium, provided that you conspicuously and appropriately publish on each copy an appropriate copyright notice and disclaimer of warranty; keep intact all the notices that refer to this License and to the absence of any warranty; and distribute a copy of this License along with the Library.

You may charge a fee for the physical act of transferring a copy, and you may at your option offer warranty protection in exchange for a fee.

2. You may modify your copy or copies of the Library or any portion of it, thus forming a work based on the Library, and copy and distribute such modifications or work under the terms of Section 1 above, provided that you also meet all of these conditions: a) The modified work must itself be a software library. b) You must cause the files modified to carry prominent notices stating that you changed the files and the date of any change. c) You must cause the whole of the work to be licensed at no charge to all third parties under the terms of this License. d) If a facility in the modified Library refers to a function or a table of data to be supplied by an application program that uses the facility, other than as an argument passed when the facility is invoked, then you must make a good faith effort to ensure that, in the event an application does not supply such function or table, the facility still operates, and performs whatever part of its purpose remains meaningful. (For example, a function in a library to compute square roots has a purpose that is entirely well-defined independent of the application. Therefore, Subsection 2d requires that any application-supplied function or table used by this function must be optional: if the application does not supply it, the square root function must still compute square roots.)

These requirements apply to the modified work as a whole. If identifiable sections of that work are not derived from the Library, and can be reasonably considered independent and separate works in themselves, then this License, and its terms, do not apply to those sections when you distribute them as separate works. But when you distribute the same sections as part of a whole which is a work based on the Library, the distribution of the whole must be on the terms of this License, whose permissions for other licensees extend to the entire whole, and thus to each and every part regardless of who wrote it.

Thus, it is not the intent of this section to claim rights or contest your rights to work written entirely by you; rather, the intent is to exercise the right to control the distribution of derivative or collective works based on the Library. In addition, mere aggregation of another work not based on the Library with the Library (or with a work based on the Library) on a volume of a storage or distribution medium does not bring the other work under the scope of this License.

3. You may opt to apply the terms of the ordinary GNU General Public License instead of this License to a given copy of the Library. To do this, you must alter all the notices that refer to this License, so that they refer to the ordinary GNU General Public License, version 2, instead of to this License. (If a newer version than version 2 of the ordinary GNU General Public License has appeared, then you can specify that version instead if you wish.) Do not make any other change in these notices.

Once this change is made in a given copy, it is irreversible for that copy, so the ordinary GNU General Public License applies to all subsequent copies and derivative works made from that copy. This option is useful when you wish to copy part of the code of the Library into a program that is not a library.

4. You may copy and distribute the Library (or a portion or derivative of it, under Section 2) in object code or executable form under the terms of Sections 1 and 2 above provided that you accompany it with the complete corresponding machine-readable source code, which must be distributed under the terms of Sections 1 and 2 above on a medium customarily used for software interchange.

If distribution of object code is made by offering access to copy from a designated place, then offering equivalent access to copy the source code from the same place satisfies the requirement to distribute the source code, even though third parties are not compelled to copy the source along with the object code.

5. A program that contains no derivative of any portion of the Library, but is designed to work with the Library by being compiled or linked with it, is called a "work that uses the Library". Such a work, in isolation, is not a derivative work of the Library, and therefore falls outside the scope of this License. However, linking a "work that uses the Library" with the Library creates an executable that is a derivative of the Library (because it contains portions of the Library), rather than a "work that uses the library".

The executable is therefore covered by this License. Section 6 states terms for distribution of such executables.

When a "work that uses the Library" uses material from a header file that is part of the Library, the object code for the work may be a derivative work of the Library even though the source code is not. Whether this is true is especially significant if the work can be linked without the Library, or if the work is itself a library. The threshold for this to be true is not precisely defined by law.

If such an object file uses only numerical parameters, data structure layouts and accessors, and small macros and small inline functions (ten lines or less in length), then the use of the object file is unrestricted, regardless of whether it is legally a derivative work. (Executables containing this object code plus portions of the Library will still fall under Section 6.)

Otherwise, if the work is a derivative of the Library, you may distribute the object code for the work under the terms of Section 6. Any executables containing that work also fall under Section 6, whether or not they are linked directly with the Library itself.

6. As an exception to the Sections above, you may also combine or link a "work that uses the Library" with the Library to produce a work containing portions of the Library, and distribute that work under terms of your choice, provided that the terms permit modification of the work for the customer's own use and reverse engineering for debugging such modifications.

You must give prominent notice with each copy of the work that the Library is used in it and that the Library and its use are covered by this License. You must supply a copy of this License. If the work during execution displays copyright notices, you must include the copyright notice for the Library among them, as well as a reference directing the user to the copy of this License. Also, you must do one of these things: a) Accompany the work with the complete corresponding machine-readable source code for the Library including whatever changes were used in the work (which must be distributed under Sections 1 and 2 above); and, if the work is an executable linked with the Library, with the complete machine-readable "work that uses the Library", as object code and/or source code, so that the user can modify the Library and then relink to produce a modified executable containing the modified Library. (It is understood that the user who changes the contents of definitions files in the Library will not necessarily be able to recompile the application to use the modified definitions.) b) Use a suitable shared library mechanism for linking with the Library. A suitable mechanism is one that (1) uses at run time a copy of the library already present on the user's computer system, rather than copying library functions into the executable, and (2) will operate properly with a modified version of the library, if the user installs one, as long as the modified version is interface-compatible with the version that the work was made with. c) Accompany the work with a written offer, valid for at least three years, to give the same user the materials specified in Subsection 6a, above, for a charge no more than the cost of performing this distribution. d) If distribution of the work is made by offering access to copy from a designated place, offer equivalent access to copy the above specified materials from the same place. e) Verify that the user has already received a copy of these materials or that you have already sent this user a copy. For an executable, the required form of the "work that uses the Library" must include any data and utility programs

needed for reproducing the executable from it. However, as a special exception, the materials to be distributed need not include anything that is normally distributed (in either source or binary form) with the major components (compiler, kernel, and so on) of the operating system on which the executable runs, unless that component itself accompanies the executable.

It may happen that this requirement contradicts the license restrictions of other proprietary libraries that do not normally accompany the operating system. Such a contradiction means you cannot use both them and the Library together in an executable that you distribute.

7. You may place library facilities that are a work based on the Library side-by-side in a single library together with other library facilities not covered by this License, and distribute such a combined library, provided that the separate distribution of the work based on the Library and of the other library facilities is otherwise permitted, and provided that you do these two things: a) Accompany the combined library with a copy of the same work based on the Library, uncombined with any other library facilities. This must be distributed under the terms of the Sections above. b) Give prominent notice with the combined library of the fact that part of it is a work based on the Library, and explaining where to find the accompanying uncombined form of the same work.

8. You may not copy, modify, sublicense, link with, or distribute the Library except as expressly provided under this License. Any attempt otherwise to copy, modify, sublicense, link with, or distribute the Library is void, and will automatically terminate your rights under this License. However, parties who have received copies, or rights, from you under this License will not have their licenses terminated so long as such parties remain in full compliance.

9. You are not required to accept this License, since you have not signed it. However, nothing else grants you permission to modify or distribute the Library or its derivative works. These actions are prohibited by law if you do not accept this License. Therefore, by modifying or distributing the Library (or any work based on the Library), you indicate your acceptance of this License to do so, and all its terms and conditions for copying, distributing or modifying the Library or works based on it.

10. Each time you redistribute the Library (or any work based on the Library), the recipient automatically receives a license from the original licensor to copy, distribute, link with or modify the Library subject to these terms and conditions. You may not impose any further restrictions on the recipients' exercise of the rights granted herein. You are not responsible for enforcing compliance by third parties with this License.

11. If, as a consequence of a court judgment or allegation of patent infringement or for any other reason (not limited to patent issues), conditions are imposed on you (whether by court order, agreement or otherwise) that contradict the conditions of this License, they do not excuse you from the conditions of this License. If you

cannot distribute so as to satisfy simultaneously your obligations under this License and any other pertinent obligations, then as a consequence you may not distribute the Library at all. For example, if a patent license would not permit royalty-free redistribution of the Library by all those who receive copies directly or indirectly through you, then the only way you could satisfy both it and this License would be to refrain entirely from distribution of the Library.

If any portion of this section is held invalid or unenforceable under any particular circumstance, the balance of the section is intended to apply, and the section as a whole is intended to apply in other circumstances.

It is not the purpose of this section to induce you to infringe any patents or other property right claims or to contest validity of any such claims; this section has the sole purpose of protecting the integrity of the free software distribution system which is implemented by public license practices. Many people have made generous contributions to the wide range of software distributed through that system in reliance on consistent application of that system; it is up to the author/donor to decide if he or she is willing to distribute software through any other system and a licensee cannot impose that choice.

This section is intended to make thoroughly clear what is believed to be a consequence of the rest of this License.

12. If the distribution and/or use of the Library is restricted in certain countries either by patents or by copyrighted interfaces, the original copyright holder who places the Library under this License may add an explicit geographical distribution limitation excluding those countries, so that distribution is permitted only in or among countries not thus excluded. In such case, this License incorporates the limitation as if written in the body of this License.

13. The Free Software Foundation may publish revised and/or new versions of the Lesser General Public License from time to time. Such new versions will be similar in spirit to the present version, but may differ in detail to address new problems or concerns. Each version is given a distinguishing version number. If the Library specifies a version number of this License which applies to it and "any later version", you have the option of following the terms and conditions either of that version or of any later version published by the Free Software Foundation. If the Library does not specify a license version number, you may choose any version ever published by the Free Software Foundation.

14. If you wish to incorporate parts of the Library into other free programs whose distribution conditions are incompatible with these, write to the author to ask for permission. For software which is copyrighted by the Free Software Foundation, write to the Free Software Foundation; we sometimes make exceptions for this. Our decision will be guided by the two goals of preserving the free status of all derivatives of our free software and of

promoting the sharing and reuse of software generally.

#### NO WARRANTY

15. BECAUSE THE LIBRARY IS LICENSED FREE OF CHARGE, THERE IS NO WARRANTY FOR THE LIBRARY, TO THE EXTENT PERMITTED BY APPLICABLE LAW. EXCEPT WHEN OTHERWISE STATED IN WRITING THE COPYRIGHT HOLDERS AND/OR OTHER PARTIES PROVIDE THE LIBRARY "AS IS" WITHOUT WARRANTY OF ANY KIND, EITHER EXPRESSED OR IMPLIED, INCLUDING, BUT NOT LIMITED TO, THE IMPLIED WARRANTIES OF MERCHANTABILITY AND FITNESS FOR A PARTICULAR PURPOSE. THE ENTIRE RISK AS TO THE QUALITY AND PERFORMANCE OF THE LIBRARY IS WITH YOU. SHOULD THE LIBRARY PROVE DEFECTIVE, YOU ASSUME THE COST OF ALL NECESSARY SERVICING, REPAIR OR CORRECTION.

16. IN NO EVENT UNLESS REQUIRED BY APPLICABLE LAW OR AGREED TO IN WRITING WILL ANY COPYRIGHT HOLDER, OR ANY OTHER PARTY WHO MAY MODIFY AND/OR REDISTRIBUTE THE LIBRARY AS PERMITTED ABOVE, BE LIABLE TO YOU FOR DAMAGES, INCLUDING ANY GENERAL, SPECIAL, INCIDENTAL OR CONSEQUENTIAL DAMAGES ARISING OUT OF THE USE OR INABILITY TO USE THE LIBRARY (INCLUDING BUT NOT LIMITED TO LOSS OF DATA OR DATA BEING RENDERED INACCURATE OR LOSSES SUSTAINED BY YOU OR THIRD PARTIES OR A FAILURE OF THE LIBRARY TO OPERATE WITH ANY OTHER SOFTWARE), EVEN IF SUCH HOLDER OR OTHER PARTY HAS BEEN ADVISED OF THE POSSIBILITY OF SUCH DAMAGES.

---

GNU LESSER GENERAL PUBLIC LICENSE Version 3,  
29 June 2007 Copyright © 2007 Free Software  
Foundation, Inc. <http://fsf.org/>

Everyone is permitted to copy and distribute verbatim copies of this license document, but changing it is not allowed. This version of the GNU Lesser General Public License incorporates the terms and conditions of version 3 of the GNU General Public License, supplemented by the additional permissions listed below.

#### 0. Additional Definitions.

As used herein, "this License" refers to version 3 of the GNU Lesser General Public License, and the "GNU GPL" refers to version 3 of the GNU General Public License. "The Library" refers to a covered work governed by this License, other than an Application or a Combined Work as defined below.

An "Application" is any work that makes use of an interface provided by the Library, but which is not otherwise based on the Library. Defining a subclass of a class defined by the Library is deemed a mode of using an interface provided by the Library.

A "Combined Work" is a work produced by combining or linking an Application with the Library. The particular

version of the Library with which the Combined Work was made is also called the “Linked Version”.

The “Minimal Corresponding Source” for a Combined Work means the Corresponding Source for the Combined Work, excluding any source code for portions of the Combined Work that, considered in isolation, are based on the Application, and not on the Linked Version.

The “Corresponding Application Code” for a Combined Work means the object code and/or source code for the Application, including any data and utility programs needed for reproducing the Combined Work from the Application, but excluding the System Libraries of the Combined Work.

1. Exception to Section 3 of the GNU GPL.

You may convey a covered work under sections 3 and 4 of this License without being bound by section 3 of the GNU GPL.

2. Conveying Modified Versions.

If you modify a copy of the Library, and, in your modifications, a facility refers to a function or data to be supplied by an Application that uses the facility (other than as an argument passed when the facility is invoked), then you may convey a copy of the modified version: a) under this License, provided that you make a good faith effort to ensure that, in the event an Application does not supply the function or data, the facility still operates, and performs whatever part of its purpose remains meaningful, or b) under the GNU GPL, with none of the additional permissions of this License applicable to that copy.

3. Object Code Incorporating Material from Library Header Files.

The object code form of an Application may incorporate material from a header file that is part of the Library. You may convey such object code under terms of your choice, provided that, if the incorporated material is not limited to numerical parameters, data structure layouts and accessors, or small macros, inline functions and templates (ten or fewer lines in length), you do both of the following: a) Give prominent notice with each copy of the object code that the Library is used in it and that the Library and its use are covered by this License. b) Accompany the object code with a copy of the GNU GPL and this license document.

4. Combined Works.

You may convey a Combined Work under terms of your choice that, taken together, effectively do not restrict modification of the portions of the Library contained in the Combined Work and reverse engineering for debugging such modifications, if you also do each of the following: a) Give prominent notice with each copy of the Combined Work that the Library is used in it and that the Library and its use are covered by this License. b) Accompany the Combined Work with a copy of the GNU GPL and this license document. c) For a Combined Work that displays copyright notices during execution, include the copyright notice for the Library among these notices, as well as a reference directing the user to the copies of the GNU

GPL and this license document. d) Do one of the following: 0) Convey the Minimal Corresponding Source under the terms of this License, and the Corresponding Application Code in a form suitable for, and under terms that permit, the user to recombine or relink the Application with a modified version of the Linked Version to produce a modified Combined Work, in the manner specified by section 6 of the GNU GPL for conveying Corresponding Source. 1) Use a suitable shared library mechanism for linking with the Library. A suitable mechanism is one that (a) uses at run time a copy of the Library already present on the user's computer system, and (b) will operate properly with a modified version of the Library that is interface-compatible with the Linked Version. e) Provide Installation Information, but only if you would otherwise be required to provide such information under section 6 of the GNU GPL, and only to the extent that such information is necessary to install and execute a modified version of the Combined Work produced by recombining or relinking the Application with a modified version of the Linked Version. (If you use option 4d0, the Installation Information must accompany the Minimal Corresponding Source and Corresponding Application Code. If you use option 4d1, you must provide the Installation Information in the manner specified by section 6 of the GNU GPL for conveying Corresponding Source.)

5. Combined Libraries.

You may place library facilities that are a work based on the Library side by side in a single library together with other library facilities that are not Applications and are not covered by this License, and convey such a combined library under terms of your choice, if you do both of the following: a) Accompany the combined library with a copy of the same work based on the Library, uncombined with any other library facilities, conveyed under the terms of this License. b) Give prominent notice with the combined library that part of it is a work based on the Library, and explaining where to find the accompanying uncombined form of the same work.

6. Revised Versions of the GNU Lesser General Public License.

The Free Software Foundation may publish revised and/or new versions of the GNU Lesser General Public License from time to time. Such new versions will be similar in spirit to the present version, but may differ in detail to address new problems or concerns.

Each version is given a distinguishing version number. If the Library as you received it specifies that a certain numbered version of the GNU Lesser General Public License “or any later version” applies to it, you have the option of following the terms and conditions either of that published version or of any later version published by the Free Software Foundation. If the Library as you received it does not specify a version number of the GNU Lesser General Public License, you may choose any version of the GNU Lesser General Public License ever published by the Free Software Foundation.



If the Library as you received it specifies that a proxy can decide whether future versions of the GNU Lesser General Public License shall apply, that proxy's public statement of acceptance of any version is permanent authorization for you to choose that version for the Library.

---

Apache LICENSE Version 2.0, January 2004  
<http://www.apache.org/licenses/> TERMS AND  
CONDITIONS FOR USE, REPRODUCTION, AND  
DISTRIBUTION

#### 1. Definitions.

"License" shall mean the terms and conditions for use, reproduction, and distribution as defined by Sections 1 through 9 of this document. "Licensor" shall mean the copyright owner or entity authorized by the copyright owner that is granting the License.

"Legal Entity" shall mean the union of the acting entity and all other entities that control, are controlled by, or are under common control with that entity. For the purposes of this definition, "control" means (i) the power, direct or indirect, to cause the direction or management of such entity, whether by contract or otherwise, or (ii) ownership of fifty percent (50%) or more of the outstanding shares, or (iii) beneficial ownership of such entity. "You" (or "Your") shall mean an individual or Legal Entity exercising permissions granted by this License. "Source" form shall mean the preferred form for making modifications, including but not limited to software source code, documentation source, and configuration files.

"Contribution" shall mean any work of authorship, including the original version of the Work and any modifications or additions to that Work or Derivative Works thereof, that is intentionally submitted to Licensor for inclusion in the Work by the copyright owner or by an individual or Legal Entity authorized to submit on behalf of the copyright owner. For the purposes of this definition, "submitted" means any form of electronic, verbal, or written communication sent to the Licensor or its representatives, including but not limited to communication on electronic mailing lists, source code control systems, and issue tracking systems that are managed by, or on behalf of, the Licensor for the purpose of discussing and improving the Work, but excluding communication that is conspicuously marked or otherwise designated in writing by the copyright owner as "Not a Contribution."

"Contributor" shall mean Licensor and any individual or Legal Entity on behalf of whom a Contribution has been received by Licensor and subsequently incorporated within the Work.

2. Grant of Copyright License. Subject to the terms and conditions of this License, each Contributor hereby grants to You a perpetual, worldwide, non-exclusive, no-charge, royalty-free, irrevocable copyright license to reproduce, prepare Derivative Works of, publicly display, publicly perform, sublicense, and distribute the Work and such Derivative Works in Source or Object form.

3. Grant of Patent License. Subject to the terms and conditions of this License, each Contributor hereby grants to You a perpetual, worldwide, non-exclusive, no-charge, royalty-free, irrevocable (except as stated in this section) patent license to make, have made, use, offer to sell, sell, import, and otherwise transfer the Work, where such license applies only to those patent claims licensable by such Contributor that are necessarily infringed by their Contribution(s) alone or by combination of their Contribution(s) with the Work to which such Contribution(s) was submitted. If You institute patent litigation against any entity (including a cross-claim or counterclaim in a lawsuit) alleging that the Work or a Contribution incorporated within the Work constitutes direct or contributory patent infringement, then any patent licenses granted to You under this License for that Work shall terminate as of the date such litigation is filed.

4. Redistribution. You may reproduce and distribute copies of the Work or Derivative Works thereof in any medium, with or without modifications, and in Source or Object form, provided that you meet the following conditions: (a) You must give any other recipients of the Work or Derivative Works a copy of this License; and (b) You must cause any modified files to carry prominent notices stating that You changed the files; and (c) You must retain, in the Source form of any Derivative Works that You distribute, all copyright, patent, trademark, and attribution notices from the Source form of the Work, excluding those notices that do not pertain to any part of the Derivative Works; and (d) If the Work includes a "NOTICE" text file as part of its distribution, then any Derivative Works that You distribute must include a readable copy of the attribution notices contained within such NOTICE file, excluding those notices that do not pertain to any part of the Derivative Works, in at least one of the following places: within a NOTICE text file distributed as part of the Derivative Works; within the Source form or documentation, if provided along with the Derivative Works; or, within a display generated by the Derivative Works, if and wherever such third-party notices normally appear. The contents of the NOTICE file are for informational purposes only and do not modify the License. You may add Your own attribution notices within Derivative Works that You distribute, alongside or as an addendum to the NOTICE text from the Work, provided that such additional attribution notices cannot be construed as modifying the License.

You may add Your own copyright statement to Your modifications and may provide additional or different license terms and conditions for use, reproduction, or distribution of Your modifications, or for any such Derivative Works as a whole, provided Your use, reproduction, and distribution of the Work otherwise complies with the conditions stated in this License.

5. Submission of Contributions. Unless You explicitly state otherwise, any Contribution intentionally submitted for inclusion in the Work by You to the Licensor shall be under the terms and conditions of this License, without

any additional terms or conditions.

Notwithstanding the above, nothing herein shall supersede or modify the terms of any separate license agreement you may have executed with Licensor regarding such Contributions.

6. Trademarks. This License does not grant permission to use the trade names, trademarks, service marks, or product names of the Licensor, except as required for reasonable and customary use in describing the origin of the Work and reproducing the content of the NOTICE file.

7. Disclaimer of Warranty. Unless required by applicable law or agreed to in writing, Licensor provides the Work (and each Contributor provides its Contributions) on an "AS IS" BASIS, WITHOUT WARRANTIES OR CONDITIONS OF ANY KIND, either express or implied, including, without limitation, any warranties or conditions of TITLE, NON-INFRINGEMENT, MERCHANTABILITY, or FITNESS FOR A PARTICULAR PURPOSE.

You are solely responsible for determining the appropriateness of using or redistributing the Work and assume any risks associated with Your exercise of permissions under this License.

8. Limitation of Liability. In no event and under no legal theory, whether in tort (including negligence), contract, or otherwise, unless required by applicable law (such as deliberate and grossly negligent acts) or agreed to in writing, shall any Contributor be liable to You for damages, including any direct, indirect, special, incidental, or consequential damages of any character arising as a result of this License or out of the use or inability to use the Work (including but not limited to damages for loss of goodwill, work stoppage, computer failure or malfunction, or any and all other commercial damages or losses), even if such Contributor has been advised of the possibility of such damages.

9. Accepting Warranty or Additional Liability. While redistributing the Work or Derivative Works thereof, You may choose to offer, and charge a fee for, acceptance of support, warranty, indemnity, or other liability obligations and/or rights consistent with this License. However, in accepting such obligations, You may act only on Your own behalf and on Your sole responsibility, not on behalf of any other Contributor, and only if You agree to indemnify, defend, and hold each Contributor harmless for any liability incurred by, or claims asserted against, such Contributor by reason of your accepting any such warranty or additional liability.

---

# 故障排除和支持

## 16.1

### 故障检修

#### 频道

安装时未找到数字频道

为确保您所在国家/地区的电视支持 DVB-T 或 DVB-C，请参阅技术规格。

确保所有线缆均已正确连接且已选择正确的网络。

频道列表中没有以前安装的频道

确保选择了正确的频道列表。

#### 概述

电视无法开机

- 将电源线与电源插座断开。等待 1 分钟，然后重新连接。
- 确保稳固连接电源线。

打开或关闭电视时出现吱吱声

打开、关闭电视或将其切换至待机模式时，听到电视机底座发出吱吱声。吱吱声是由电视正常的热胀冷缩引起的。这并不影响电视性能。

电视对遥控器无响应

电视启动需要一段时间。在此期间，电视将无法对遥控器或电视机控件作出响应。这是正常现象。

如果电视对遥控器仍无响应，您可以用手机摄像头检查遥控器是否工作正常。将手机设置为摄影模式，然后将遥控器指向镜头。如果按遥控器上的任意键，通过摄像头可以看到红外 LED

闪烁，则表明遥控器工作正常。需要检查电视。

如果未看到闪烁，则遥控器可能已损坏或其电池电量过低。

这种检查遥控器的方式不适用于通过无线方式与电视配对的遥控器。

电视在显示飞利浦启动屏幕后返回待机模式



电视处于待机模式时会显示飞利浦启动屏幕，然后再返回待机模式。这是正常现象。当电视断开并重新连接电源时，会在下次启动时显示启动屏幕。要从待机模式打开电视，请按遥控器或电视。

待机指示灯持续闪烁

将电源线与电源插座断开。等待 5 分钟，然后重新连接。如果继续闪烁，请联系飞利浦电视客户服务部门。

菜单显示错误语言

将语言改回您的语言。

1. 按  并选择设置，然后按 OK。
2. 选择电视设置 > 一般设置 > 菜单语言，然后按 OK。
3. 选择所需语言，然后按 OK。
4. 按  (如有必要，请反复按) 关闭菜单。

#### 画面

无画面/画面失真

- 确保天线已正确连接至电视。
- 确保选取正确的设备作为显示源。
- 确保已正确连接外置设备或来源。

有声音无画面

- 确保正确设置画面设置。

天线接收效果不佳

- 确保天线已正确连接至电视。
- 扬声器、未接地的音响设备、氖灯、高大的建筑物以及其他较大的物体会影响接收质量。尽量通过改变天线方向或让设备远离电视来改善信号接收质量。
- 如果只有一个频道的信号较差，请对该频道进行微调。

设备的画质较差

- 确保正确连接设备。
- 确保正确设置画面设置。

画面设置片刻后更改

确保将位置设置为家庭。在该模式下，您可以更改并保存设置。

出现商业横幅

确保将位置设置为家庭。

画面与屏幕不匹配

更改为其他画面格式。按 。

画面格式随着不同频道不断变化

选择非“自动”画面格式。

画面位置不正确

有些设备的画面信号可能无法正确匹配屏幕。检查所连接设备的信号输出。

电脑画面不稳定

确保电脑使用支持的分辨率和刷新率。

---

## 声音

### 无声音或音质很差

如果没有检测到音频信号，电视机将自动关闭音频输出，这并不表示有故障。

- 确保正确设置声音设置。
- 确保正确连接所有线缆。
- 确保音量未静音或设为零。
- 确保电视音频输出已连接至家庭影院系统的音频输入。
- 应通过 HTS 扬声器播放声音。
- 有些设备可能需要手动启用 HDMI 音频输出。如果已启用 HDMI 音频，但仍无法听到声音，尝试将设备的数字音频格式更改为 PCM (脉冲编码调制)。有关说明，请参阅设备附带的文档。

---

## 连接

### HDMI

- 请注意，HDCP (高带宽数字内容保护) 支持会延迟电视显示 HDMI 设备内容的时间。
- 如果电视无法识别 HDMI 设备并且未显示画面，则切换为其他来源设备，然后切换回当前设备。
- 如果出现间歇性的声音失真，确保 HDMI 设备的输出设置正确。
- 如果使用 HDMI-to-DVI 适配器或 HDMI-to-DVI 线缆，在适用情况下，确保将其他音频线缆连接至 AUDIO IN (仅限迷你插孔)。

### EasyLink 功能不起作用

- 确保 HDMI 设备兼容 HDMI-CEC。EasyLink 功能只能与兼容 HDMI-CEC 的设备配合使用。

### 未显示音量图标

- 这在连接 HDMI-CEC 音频设备时是正常现象。

### 未显示 USB 设备中的照片、视频和音乐

- 确保已按存储设备文档中所述将 USB 存储设备设置为兼容海量存储类。
- 确保 USB 存储设备与电视兼容。
- 确保电视支持这些音频和图片文件格式。

### USB 文件播放不流畅

- USB 存储设备的传输性能可能会限制与电视机之间的数据传输速率，这会影响播放质量。

---

16.2

## 注册

注册您的电视，即可享受包括全部支持 (含下载)、专享有关新产品的信息、独家优惠和折扣、获奖的机会以及参与有关新发布产品的特殊调查在内的一系列优惠政策。

访问 [www.philips.com/welcome](http://www.philips.com/welcome)

---

16.3

## 帮助

本电视提供屏幕帮助。

### 打开帮助

1. 按 **▲** 打开主菜单。
2. 选择帮助，然后按 OK。

nvk\_v8\_20140827

---

16.4

## 在线帮助

要解决飞利浦电视相关问题，可以咨询我们的在线支持。您可以选择您的语言并输入产品型号。

转至 [www.philips.com/support](http://www.philips.com/support)。

在支持站点上，您可以找到用于联系我们以及解答常见问题 (FAQ) 的您所在国家/地区的电话号码。在部分国家/地区，您可以与我们其中一位同事交谈，直接询问问题或通过电子邮件发送问题。

您可以下载新电视软件或可在电脑上阅读的手册。

---

16.5

## 客户服务/维修

有关支持和维修，请致电您所在国家/地区的客户服务热线。电话号码位于电视随附的印刷文档中。或访问我们的网站 [www.philips.com/support](http://www.philips.com/support)。

### 电视型号和序列号

客户服务人员可能会要求您提供电视产品型号和序列号。这些号码位于包装标签或电视背部或底部的型号标签上。

### ▲ 警告

请勿尝试自行修理电视。否则可能会造成严重的人身伤害，或对电视造成不可挽回的损坏，并使产品保修无效。

---

# 安全与维护

---

## 17.1

### 安全

---

#### 重要信息

使用电视之前，请阅读并理解所有安全说明。因未遵守说明而造成的损坏不在保修范围内。

---

#### 防止电视跌落

务必使用随附的挂架以防止电视跌落。安装支架，然后将电视固定到支架上，即使将电视置于地板上。

安装说明位于电视随附的快速入门指南中。如果该指南丢失，可从 [www.philips.com](http://www.philips.com) 下载使用电视的产品类型号查找要下载的快速入门指南。

---

#### 小心触电或发生火灾

- 请勿让电视机与雨或水接触。切勿将液体容器（如花瓶）放置在电视旁边。如果有液体溅到电视表面或内部，请立即断开电视的电源。请与飞利浦电视客户服务部门联系，对电视进行检查后再行使用。
- 切勿将电视、遥控器或电池暴露在过热的环境中。切勿将它们放置在靠近明火或其它热源的地方，包括阳光直射处。
- 切勿将物体插入本电视的通风槽或其它开口。
- 切勿将重物放在电源线上。
- 避免对电源插头过度施力。电源插头松脱可能导致电弧或火灾。旋转电视机屏幕时，确保没有拉紧电源线。
- 要断开电视的电源，必须拔下电源插头。断开电源时，应始终拔动电源插头，切勿拉扯电源线。请确保您始终可以完全接触到电源插头、电源线和插座。

---

#### 小心受伤或损坏电视

- 需由两个人搬运重量超过 25 千克或 55 磅的电视。
- 将电视安装到支架上时，只能使用随附的支架。将支架紧紧地固定到电视上。将电视置于一个平整、水平的表面上，该表面必须能够支撑电视和支架的总重量。
- 壁挂时，确保壁挂能够安全地支撑电视的重量。TP Vision 对由于壁挂不当而造成的事故、人身伤害或损害不负任何责任。

- 本产品的部件由玻璃制造。请小心处理，以免受到伤害或造成损坏。

存在损坏电视机的风险！

将电视机连接到电源插座前，请确保电源电压符合电视机背面印制的电压值。如果电压值不符，绝对不能将电视机连接到电源插座。

---

#### 小心伤害儿童

请遵循下列注意事项，防止因电视掉落而导致儿童受伤：

- 切勿将电视放在盖有布块或其它可以拉动的材料的表面上。
- 确保电视的任何部分都没有悬在表面的边缘之外。
- 切勿将电视放置在较高的家具（如书柜）上，而没有将家具和电视机都固定到墙上或合适的支点上。
- 告知儿童爬上家具触摸电视可能带来的危险。

吞咽电池的危險！

遥控器可能包含纽扣式电池，容易被小孩吞咽。请始终将这些电池放在儿童接触不到的地方。

---

#### 小心过热

切勿将电视机安装在封闭空间内。始终在电视机周围留出至少 10 厘米或 4 英寸的空间以便通风。确保窗帘或其它物体不会遮挡电视上的通风槽。

---

#### 雷雨天气

在雷电天气之前，应断开电视的电源和天线。雷雨天气期间，切勿触摸电视、电源线或天线的任何部分。

---

#### 小心听力受损

避免以高音量或长时间使用耳机。

---

#### 低温

如果在低于 5°C 或 41°F 的温度下运送电视机，请先拆开电视机的包装，待电视机达到室温后再将电视机连接到电源插座上。

---

## 湿度

在极少数情况下，取决于温度和湿度，在电视正面玻璃内部可能会出现轻微结露（某些型号）。为防止此现象，请不要将电视机直接暴晒于阳光下、暴露于高温或极端潮湿环境下。如果出现结露，电视打开几小时后结露会自行消失。

结露不会损坏电视或引起故障。

---

17.2

## 屏幕保养

- 切勿使用任何物体接触、推按、摩擦或敲击屏幕。
- 在清洁前拔下电视的插头。
- 用柔软的湿布进行清洁，轻轻擦拭电视和框架。请勿使用酒精、化学品或家用清洁剂等物质清洁电视。
- 为了避免变形和褪色，请尽快擦掉水滴。

应尽量避免静态图像。静态图像是指长时间停留在屏幕上的图像。静态图像包括屏幕菜单、黑条和时间显示等。如果必须使用静态图像，请降低屏幕对比度和亮度，以防止损坏屏幕。

# 用条款、版权和授权

## 18.1

### 使用条款

2014 © TP Vision Europe B.V. 保留所有权利。

本产品由 TP Vision Europe B.V. 或其附属机构之一引入市场，下文中还提及 TP Vision 是产品的制造商。TP Vision 是本手册提及的电视相关事务的担保人。飞利浦及飞利浦盾牌标志是 Koninklijke Philips N.V. 的注册商标

规格随时可能变更，恕不另行通知。所有商标均是 Koninklijke Philips N.V. 或其各自所有者的财产。TP Vision 保留随时更改产品的权利，而且没有义务对较早前提供的产品进行相应的调整。

电视附带的书面材料和存储于电视内存中或从飞利浦网站下载的手册足够供系统正常使用。

本手册中的材料足够供系统正常使用。如果产品，或其单独模块或程序用于此处指定的其它用途，则必须获得有效性和适用性确认。TP Vision Europe B.V. 保证，材料本身并非侵犯任何美国专利。我们没有作出进一步的明示或暗示保证。TP Vision Europe B.V. 对本文档中的任何错误以及由于本文档的内容而导致的任何问题概不负责。飞利浦会尽快地纠正用户所报告的错误并将其并公布在飞利浦支持网站上。保修条款。存在人身伤害、损坏电视机或令保修失效的风险！切勿尝试自行修理电视。请仅按制造商的原本意图使用电视机和附件。电视背面的警告标志表示存在触电风险。切勿拆卸电视机盖。务必联系飞利浦电视客户服务部门进行检修。本手册中明确禁止的任何操作，或者任何未建议或授权的调整或装配步骤均会使保修失效。像素特性。本液晶显示产品具有大量的彩色像素。尽管其有效像素高达 99.999% 或更高，但屏幕仍可能出现黑点或亮点（红色、绿色或蓝色）。这是显示屏的结构属性（在常见的行业标准内）并且不是故障。CE

合规性。本产品符合指令

2006/95/EC（低电压）、2004/108/EC（EMC）和 2011/65/EU（ROHS）的基本要求及其他相关规定。EMF 方面合规性。TP Vision Europe B.V. 主要面向广大消费者制造和销售各类产品，包括通常能放射和接收电磁信号的各种电子设备。飞利浦的主要经营原则之一就是要对我们的产品采取各种必要的健康和安全措施，符合所有相应的法律要求，并在生产产品时严格遵照 EMF 标准。飞利浦致力于开发、生产和销售对人体健康无任何危害的产品。TP Vision 确认，据目前的科学证明，只要其产品使用得当，就对人体毫无危害。长期以来，飞利浦始终在国际 EMF 和安全标准的制定工作中起着积极作用，这就使飞利浦总能预知标准的发展趋势，并率先应用到其产品中去。

## 18.2

### 版权和许可

#### HDMI



HDMI®

HDMI 和 HDMI 高清多媒体接口术语及 HDMI 徽标是 HDMI Licensing LLC 在美国及其他国家/地区的商标或注册商标。

#### Dolby



Dolby®

在 Dolby Laboratories 许可下制造。Dolby 和双 D 符号是 Dolby Laboratories 的商标。

#### MHEG 软件

包含于本电视（以下简称“本产品”）中的 MHEG 软件（以下简称“软件”）及随附软件的版权使您可以使用属于 S&T CLIENT SYSTEMS LIMITED（以下简称“所有者”）的互动电视功能。仅允许您与本电视一起使用该软件。

#### Kensington



Kensington 和 Micro Saver 是 ACCO World Corporation 在美国和全球其它国家/地区已注册及正在申请的商标。

#### 其他商标

所有其他已注册和未注册的商标均是各自所有者的财产。

---

# 索引





# Contact information

**Argentina**

0800 444 7749

Buenos Aires 0810 444 7782

**België / Belgique**

070 700 035 (0,15€/min.)

**Bosna i Hercegovina**

033 941 251 (Lokalni poziv)

**Brazil**

0800 701 0245

Sao Paulo 2938 0245

**България**

02 4916 273 (Национален номер)

**Česká republika**

228880895 (Místní tarif)

**Danmark**

3525 8314

**Deutschland**

0180 501 04 69 (0,14€/Min.)

**Ελλάδα**

2111983028 (Εθνική κλήση)

**España**

902 88 10 83 (0,10€ + 0,08€/min.)

**Estonia**

6683061 (Kohalikud kõned)

**France**

01 57 32 40 50 (local)

**Hrvatska**

01 777 66 01 (Lokalni poziv)

**Italia**

0245 28 70 14 (chiamata nazionale)

**Ireland**

0818 210 140 (national call)

**Northern Ireland**

0844 338 04 88 (5p/min BT landline)

**Қазақстан**

8 10 800 2000 00 04 (free)

**Latvia**

6616 3263 (Vietējais tarifs)

**Lithuania**

8 5 214 0293 (Vietinaiis tarifais)

**Luxembourg / Luxemburg**

2487 1100 (Nationale Ruf / appel national)

**Magyarország**

06 1 700 8151 (Belföldi hívás)

**Nederland**

0900 202 08 71 (0,10€/min.)

**Norge**

22 97 19 14

**Österreich**

0820 40 11 33 (0,145€/Min.)

**Polska**

22 397 15 04 (Połączenie lokalne)

**Portugal**707 78 02 25 (0,12€/min. - Móvel  
0,30€/min.)**Română**

031 6300042 (Tarif local)

**Россия**

8-800-22 00004 (бесплатно)

**Suisse / Schweiz / Svizzera**

0848 000 291 (0,081 CHF/Min.)

**Србија**

011 321 6840 (Lokalni poziv)

**Slovakia**

2 332 154 93 (Vnútroštátny hovor)

**Slovenija**

1 888 83 12 (Lokalni klic)

**Suomi**

09 88 62 50 40

**Sverige**

08 5792 9096 (lokalsamtal)

**ประเทศไทย (Thailand)**

02 652 7650

**Türkiye**

444 8 445

**United Kingdom**

0844 338 04 88 (5p/min BT landline)

**Україна**

0-800-500-480 (безкоштовно)

[www.philips.com/support](http://www.philips.com/support)

Non-contractual images / Images non contractuelles / Außervertragliche Bilder

Specifications are subject to change without notice.

Philips and the Philips' shield emblem are registered trademarks of Koninklijke Philips N.V.

and are used under license from Koninklijke Philips Electronics N.V.

All registered and unregistered trademarks are property of their respective owners.

2014 © TP Vision Europe B.V. All rights reserved.

[www.philips.com](http://www.philips.com)

